

**PARTS LIST
FOR
MODEL XL-550**

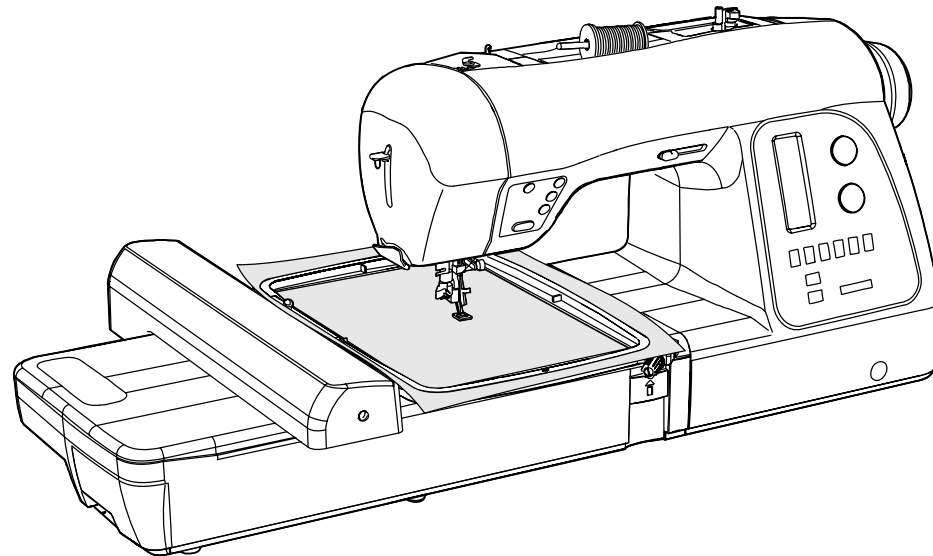

SINGER | Futura™

BUYER'S MODEL NO.	XL-550	SECTION		PAGE		REVISION		REMARKS	
BUYER'S MODEL NAME	FUTURA		1						
FACTORY MODEL	235								
ORIGINAL ISSUE	JAN , 2010			SERIAL NO.					

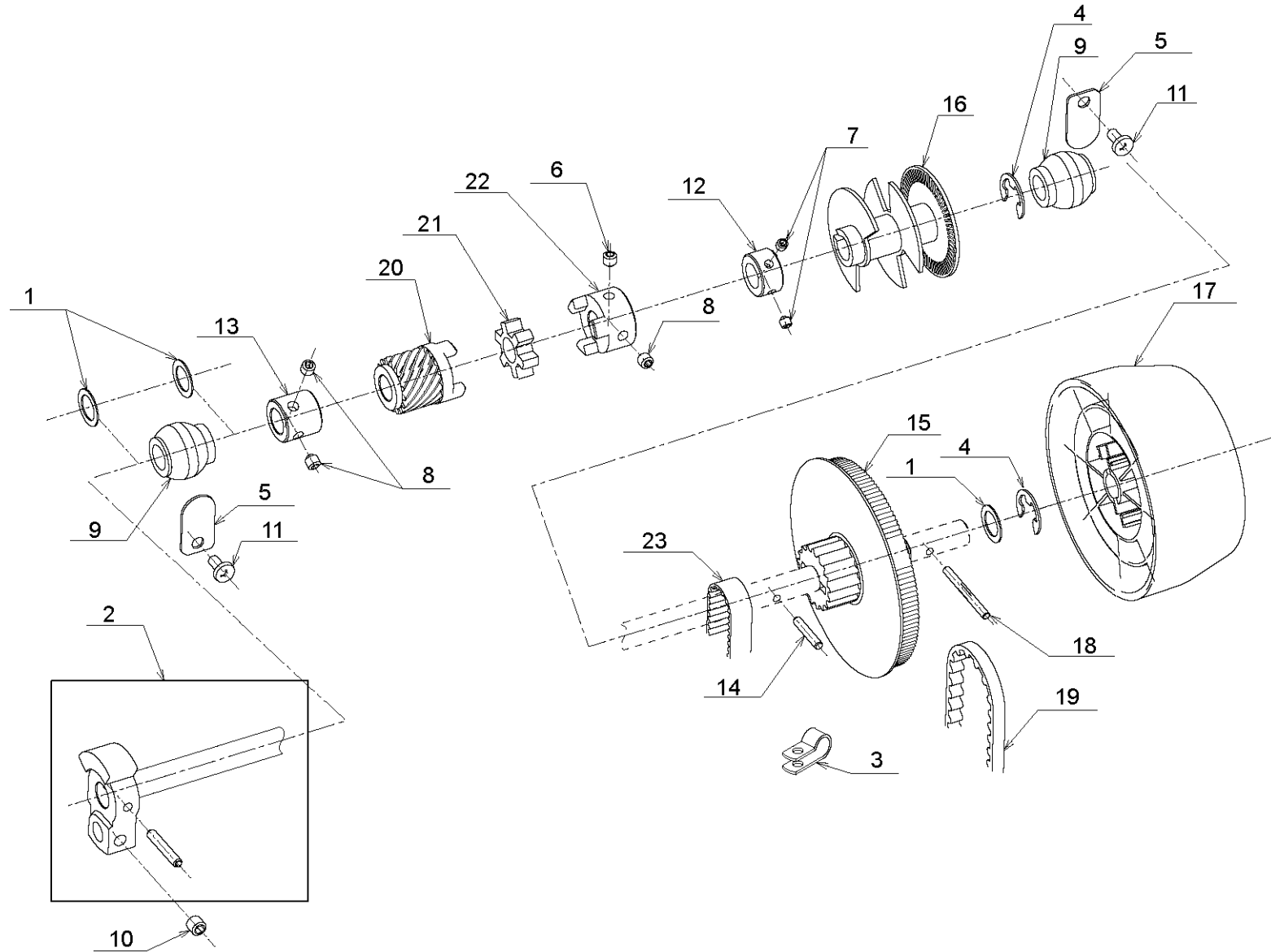

BUYER'S MODEL NO.	XL-550	SECTION		PAGE		REVISION		REMARKS	
BUYER'S MODEL NAME	FUTURA		2						
FACTORY MODEL	235								
ORIGINAL ISSUE	JAN , 2010			SERIAL NO.					

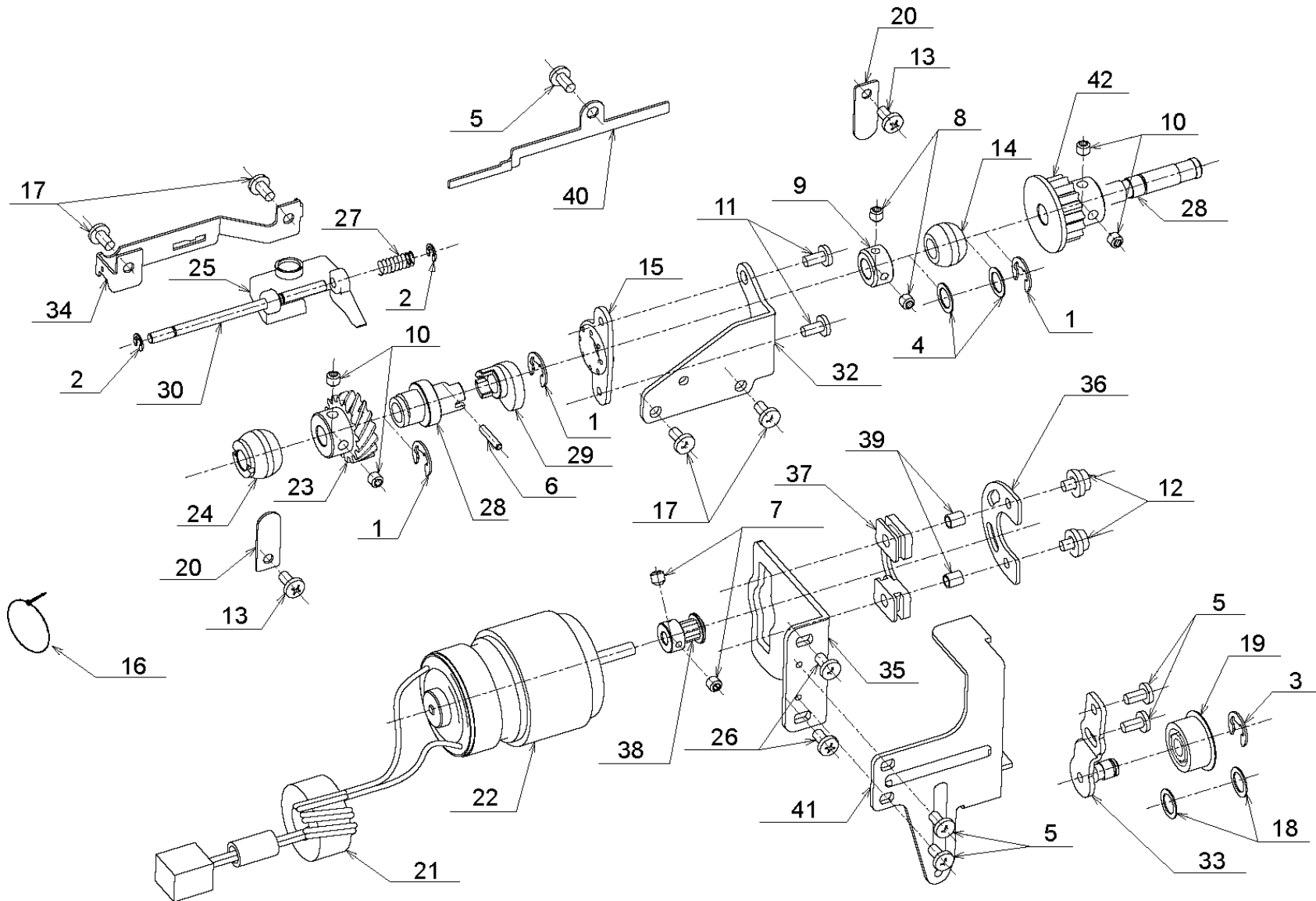

PAGE	NO.	PART NO.	DESCRIPTION
2	1	1504	E7 CLIP-ON-WASHER
2	2	1520	E3 CLIP-ON-WASHER
2	3	10963	E6 CLIP-ON-WASHER
2	4	43390	THRUST WASHER
2	5	61222	M4 PHILIPS SCREW
2	6	64179	SPRING PIN
2	7	64653	M3 SCREW
2	8	66725	M4 SCREW
2	9	67444	COLLAR
2	10	67447	M5 SCREW
2	11	72367	M4 CP SCREW
2	12	72988	CP BOLT
2	13	73434	M4 PHILIPS SCREW
2	14	76141	BALL METAL
2	15	76488	LOWER SHAFT GUIDE
2	16	77041	M4 PHILLIPS SCREW
2	17	77042	M4 PHILLIPS SCREW
2	18	77056	WASHER
2	19	85138	TENSION ROLLER
2	20	85247	SECURING PLATE
2	21	85318	FERRITE RING
2	22	85540	MAIN MOTOR ASSY.
2	23	87050	BEVEL GEAR
2	24	87170	BALL METAL
2	25	87226	VERTICAL FEED BLOCK
2	26	87261	CP BOLT
2	27	87433	TORSION SPRING
2	28	88115	LIFTING CAM
2	29	89222	LOWER SHAFT
2	30	89224	FEED CAM
2	31	89242	VERTICAL SHAFT
2	32	89243	SHAFT SUPPORT
2	33	89244	TENSION ROLLER SUPPORT
2	34	89245	DROP LEVER GUIDE
2	35	89276	MAIN MOTOR SUPPORT
2	36	89277	M BRACKET
2	37	89278	M CUSHION
2	38	89280	MOTOR PULLEY
2	39	89281	PIPE BUSH
2	40	89371	CORD GUIDE
2	41	89392	SECURING PLATE
2	42	89470	LOWER SHAFT BELT PULLEY

BUYER'S MODEL NO.	XL-550	SECTION		REVISION		REMARKS	
BUYER'S MODEL NAME	FUTURA		3				
FACTORY MODEL	235						
ORIGINAL ISSUE	JAN , 2010	SERIAL NO.					

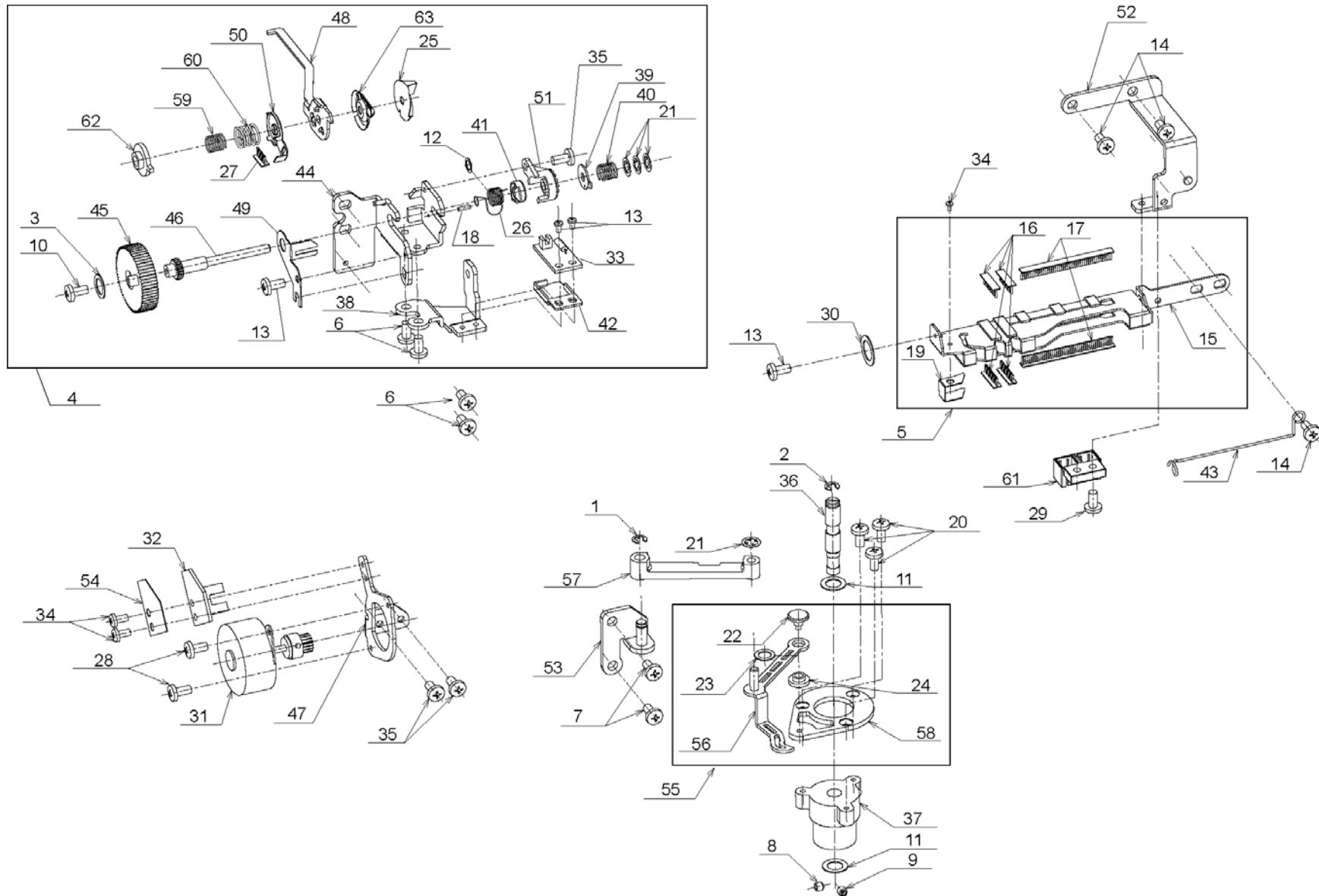

PAGE	NO.	PART NO.	DESCRIPTION
3	1	1513	E4 CLIP-ON-WASHER
3	2	8400	E5 CLIP-ON-WASHER
3	3	31246	WASHER
3	4	52087	TENSION SET
3	5	52088	THREAD GUIDE SET
3	6	61222	M4 PHILIPS SCREW
3	7	61224	M4 PHILIPS SCREW
3	8	62307	M4 SCREW
3	9	66052	M4 SCREW
3	10	66318	M3 PHILIPS SCREW
3	11	66587	THRUST WASHER
3	12	73363	THRUST WASHER
3	13	76317	M3 PHILIPS SCREW
3	14	77042	M4 PHILLIPS SCREW
3	15	77404	THREAD GUIDE
3	16	77427	BRUSH
3	17	77428	BRUSH
3	18	77429	PIN
3	19	77437	THREAD GUIDE PLATE
3	20	77506	TAPPING SCREW
3	21	77507	CLIP-ON-WASHER
3	22	77508	TAKE UP LEVER PIN
3	23	77509	WASHER
3	24	77510	BUSH
3	25	77513	TENSION DISC (R)
3	26	77515	SPRING
3	27	77609	BRUSH
3	28	80110	BOLT
3	29	85263	M3 SCREW
3	30	85273	WASHER
3	31	85532	MOTOR
3	32	85533	HARNESS
3	33	85548	NEDDLE THEARD SENSOR HARNESS
3	34	86376	M3 SCREW
3	35	87256	M3 PHILIPS SCREW
3	36	87707	STUD SCREW
3	37	87731	GEAR
3	38	87742	BRACKET
3	39	87743	ADJUST PLATE
3	40	87744	COMPRESSION SPRING
3	41	87809	CHECK SPRING
3	42	87812	INSULATION BOX
3	43	88342	GUIDE
3	44	89282	TENSION SUPPORT
3	45	89283	TENSION GEAR
3	46	89284	TENSION SHAFT
3	47	89285	TENSION MOTOR BRACKET
3	48	89286	TENSION RELEASE PLATE
3	49	89287	TENSION SHAFT PLATE
3	50	89288	SPRING SUPPORT
3	51	89289	CHECK SPRING
3	52	89290	THREAD GUIDE PLATE SUPPORT
3	53	89291	TAKE-UP LEVER SUPPORT
3	54	89292	INSULATION SHEET
3	55	89294	TAKE-UP LEVER UNIT
3	56	89295	TAKE-UP LEVER
3	57	89296	TAKE-UP LEVER ARM
3	58	89297	TAKE-UP LEVER CRANK
3	59	89298	COMPRESSION SPRING (SMALL)
3	60	89299	COMPRESSION SPRING (LARGE)
3	61	89325	LED LIGHT CASE
3	62	89384	TENSION ADJUSTING PLATE
3	63	89488	TENSION DISC (L)

BUYER'S MODEL NO.	XL-550	SECTION		REVISION		REMARKS	
BUYER'S MODEL NAME	FUTURA		4				
FACTORY MODEL	235						
ORIGINAL ISSUE	JAN , 2010	SERIAL NO.					

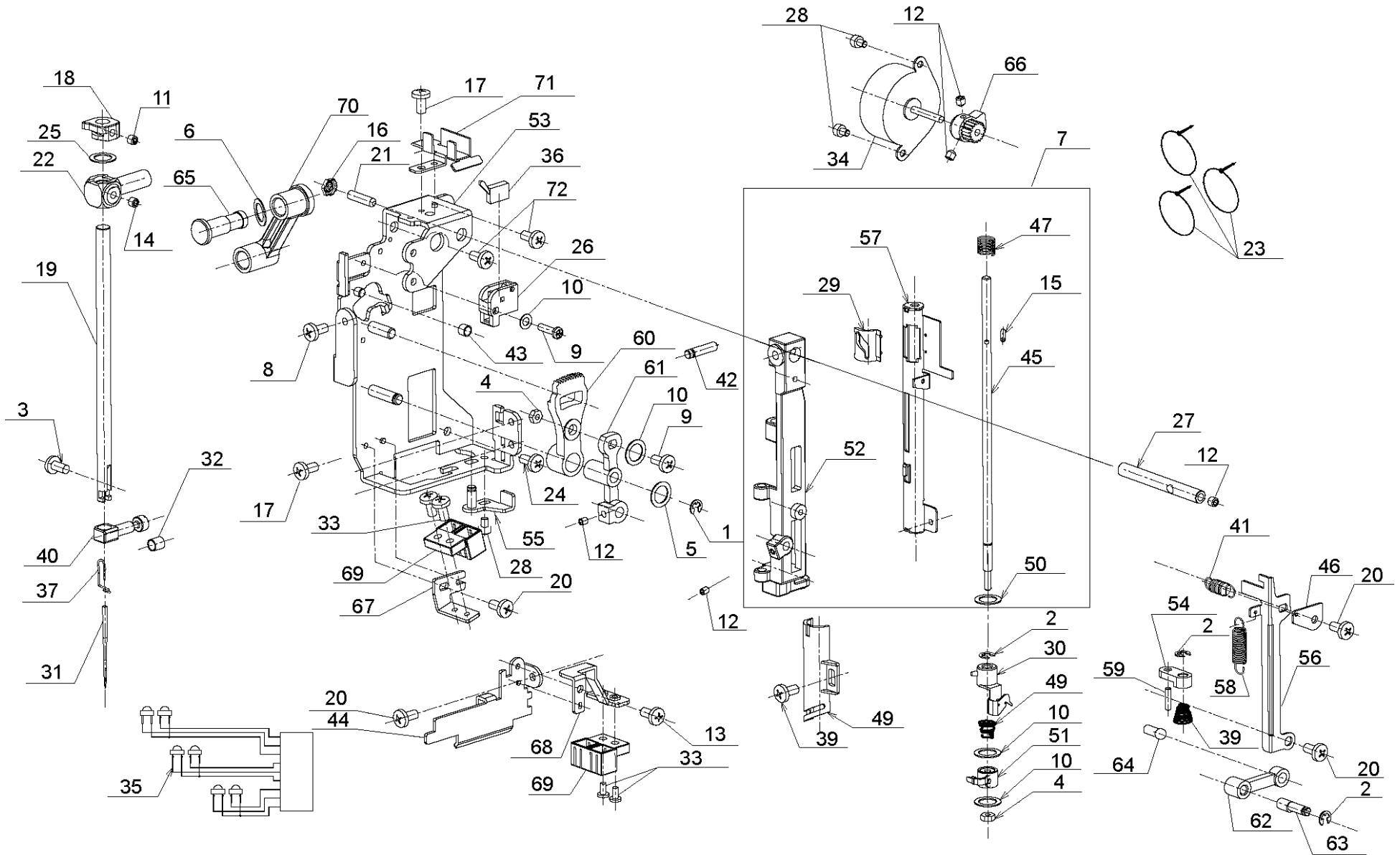

PAGE	NO.	PART NO.	DESCRIPTION
4	1	1513	E4 CLIP-ON-WASHER
4	2	1520	E3 CLIP-ON-WASHER
4	3	26934	#8 SCREW
4	4	31733	M3 NUT
4	5	32949	WASHER
4	6	43390	THRUST WASHER
4	7	52089	NEEDLE BAR SUPPORT SET
4	8	61222	M4 PHILIPS SCREW
4	9	63796	M3 SCREW
4	10	63805	WASHER
4	11	64359	M4 SCREW
4	12	64653	M3 SCREW
4	13	66318	M3 PHILIPS SCREW
4	14	66725	M4 SCREW
4	15	68343	PIN
4	16	73299	M4 TORQUE NUT
4	17	73900	M3 PHILIPS SCREW
4	18	75024	STOPPER
4	19	76183	NEEDLE BAR
4	20	76317	M3 PHILIPS SCREW
4	21	76324	M4 SCREW
4	22	77037	NEEDLE BAR CLAMP
4	23	77041	M4 PHILLIPS SCREW
4	24	77042	M4 PHILLIPS SCREW
4	25	77043	FELT
4	26	77527	SENSOR COVER
4	27	80095	STRAIGHT PIN
4	28	80110	BOLT
4	29	80296	THREAD GUIDE C
4	30	80297	TWIN THREADING HOOK SET
4	31	83122	NEEDLE
4	32	83131	TUBE
4	33	85263	M3 SCREW
4	34	85522	STEPPING MOTOR
4	35	85527	LED LAMP HARNESS
4	36	85529	STEPPING MOTOR HARNESS (ZIG ZAG)
4	37	86046	THREAD GUIDE
4	38	86376	M3 SCREW
4	39	86999	SPRING
4	40	87154	NEEDLE CLAMP SET
4	41	87188	SPRING
4	42	87207	STRAIGHT PIN
4	43	87273	PIN
4	44	88317	THREAD GUIDE PLATE
4	45	88412	THREADER SHAFT
4	46	88427	SECURING PLATE
4	47	88428	COMPRESSION SPRING
4	48	88429	THREAD GUIDE B
4	49	88432	SPRING
4	50	88433	WASHER
4	51	88453	THREAD GUIDE ASSY
4	52	89257	NEEDLE BAR SUPPORT
4	53	89258	SUPPORT BRACKET
4	54	89259	SUPPORT BRACKET
4	55	89260	SUPPORT BRACKET
4	56	89261	THEARDER GUIDE PLATE
4	57	89262	THREADER GUIDE A
4	58	89263	THREADER SPRING
4	59	89264	PIN
4	60	89265	ZZ GEAR
4	61	89266	ZZ GEAR LEVER
4	62	89267	ZZ LINK
4	63	89268	ECCENTRIC PIN
4	64	89269	ROUND SHAFT
4	65	89304	HEADED PIN
4	66	89312	PINION
4	67	89319	LED SUPPORT (LEFT)
4	68	89320	LED SUPPORT (RIGHT)
4	69	89325	LED LIGHT CASE
4	70	89357	NEEDLE BAR CRANK
4	71	89378	THREAD GUIDE
4	72	89474	SCREW

BUYER'S MODEL NO.	XL-550	SECTION		REVISION		REMARKS	
BUYER'S MODEL NAME	FUTURA		5				
FACTORY MODEL	235						
ORIGINAL ISSUE	JAN , 2010	SERIAL NO.					

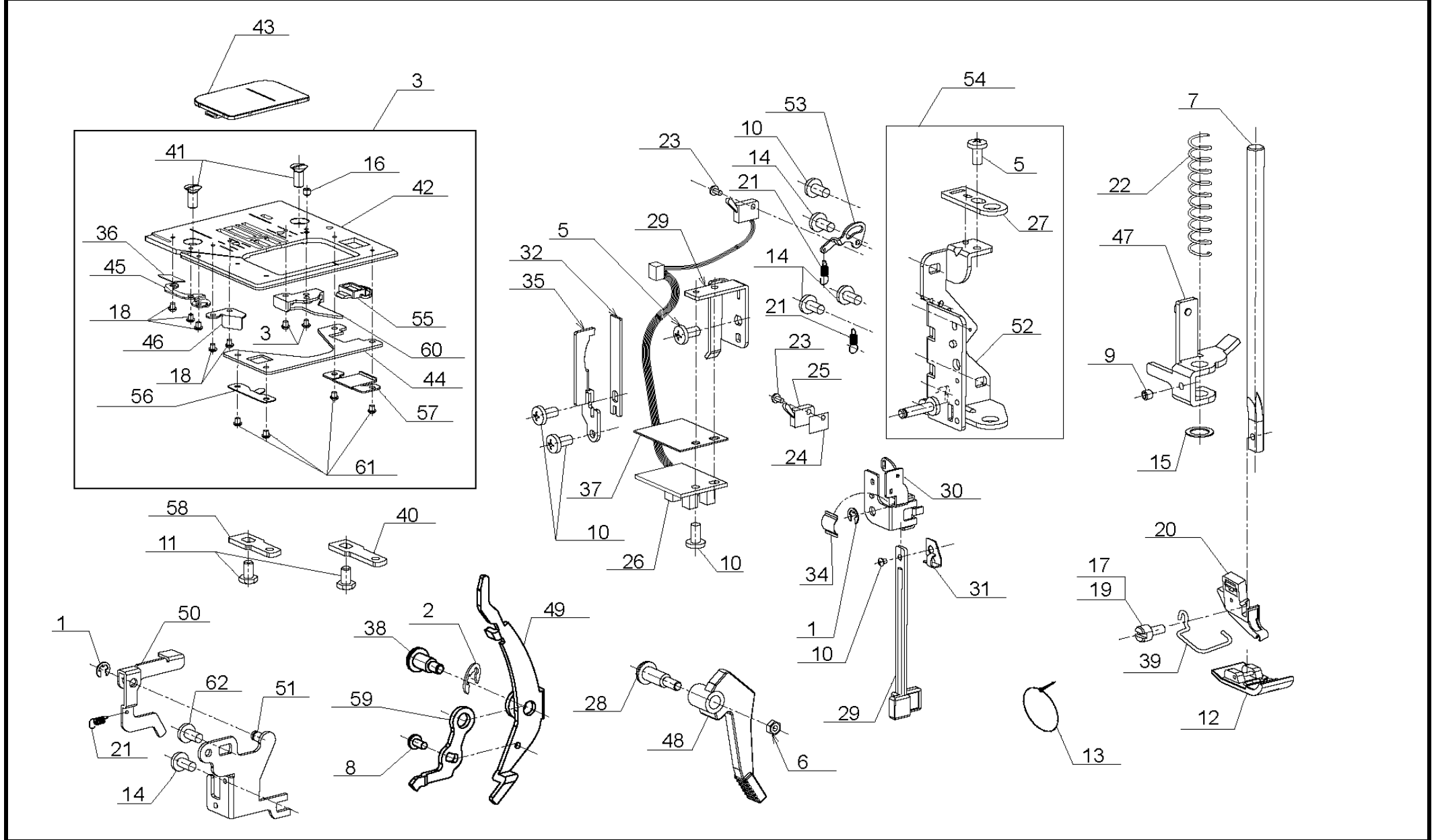

PAGE	NO.	PART NO.	DESCRIPTION
5	1	1520	E3 CLIP-ON-WASHER
5	2	8400	E5 CLIP-ON-WASHER
5	3	52090	NEEDLE PLATE SET
5	4	56858	M2 PHILIPS SCREW
5	5	61221	M4 PHILIPS SCREW
5	6	62215	M4 NUT
5	7	63278	PRESSER BAR
5	8	66318	M3 PHILIPS SCREW
5	9	66727	M4 SCREW
5	10	73900	M3 PHILIPS SCREW
5	11	74020	M4 BOLT
5	12	76251	PRESSER FOOT
5	13	77041	UNITY FASTENER
5	14	77042	M4 PHILLIPS SCREW
5	15	77043	FELT
5	16	79491	SCREW
5	17	80065	#7 SCREW FOR SHANK
5	18	80096	M2 PHILIPS SCREW
5	19	80250	SCREW FOR SHANK (ITALY ONLY)
5	20	85016	PRESSER FOOT HOLDER
5	21	85064	EXTENSION SPRING
5	22	85065	COMPRESSION SPRING
5	23	85262	M2 SCREW
5	24	85332	SPACER
5	25	85539	PRESSER FOOT POSITIONNING HARNESS
5	26	85551	BUTTON HOLE STITCH SENSOR HARNESS
5	27	87115	PRESSURE SUPPORT PLATE
5	28	87212	M4 SCREW
5	29	87677	BH PLATE (A)
5	30	87679	BH PLATE (B)
5	31	87680	BH PLATE (C)
5	32	87692	BH CANTILEVER
5	33	87693	BH PALTE
5	34	87694	LEAF SPRING
5	35	87695	BH CANTILEVER SUPPORT
5	36	87766	BLADE
5	37	88112	INSULATION SHEET
5	38	88231	STUD SCREW
5	39	88451	FINGER GUARD (ITALY ONLY)
5	40	88595	NEEDLE PLATE BRACKET
5	41	88596	M4 SCREW
5	42	89216	NEEDLE PLATE
5	43	89217	BOBBIN COVER PLATE
5	44	89218	NEEDLE PLATE GUIDE
5	45	89219	THREAD CUTTER SECURING PLATE
5	46	89220	THREAD CONTROL PLATE
5	47	89270	PRESSER BAR GUIDE
5	48	89271	PRESSER FOOT LIFTER
5	49	89272	TENSION RELEASE LEVER
5	50	89273	THREAD REGULATOR RELEASE LEVER
5	51	89274	THREAD REGULATOR RELEASE LEVER BASE
5	52	89275	PRESSER BAR GUIDE
5	53	89326	SWITCH DOG ADJUSTMENT PLATE
5	54	89351	PRESSER BAR GUIDE SET
5	55	89353	RELEASE KNOB
5	56	89354	RELEASE SPRING PLATE
5	57	89355	BRACKET
5	58	89356	NEEDLE PLATE BRACKET
5	59	89363	PRESSER SWITCH DOG
5	60	89364	THREAD CONTROL PLATE
5	61	89399	M2 PHILIPS SCREW
5	62	89474	SCREW

BUYER'S MODEL NO.	XL-550	SECTION	PAGE	REVISION	REMARKS
BUYER'S MODEL NAME	FUTURA		6		
FACTORY MODEL	235				
ORIGINAL ISSUE	JAN , 2010			SERIAL NO.	

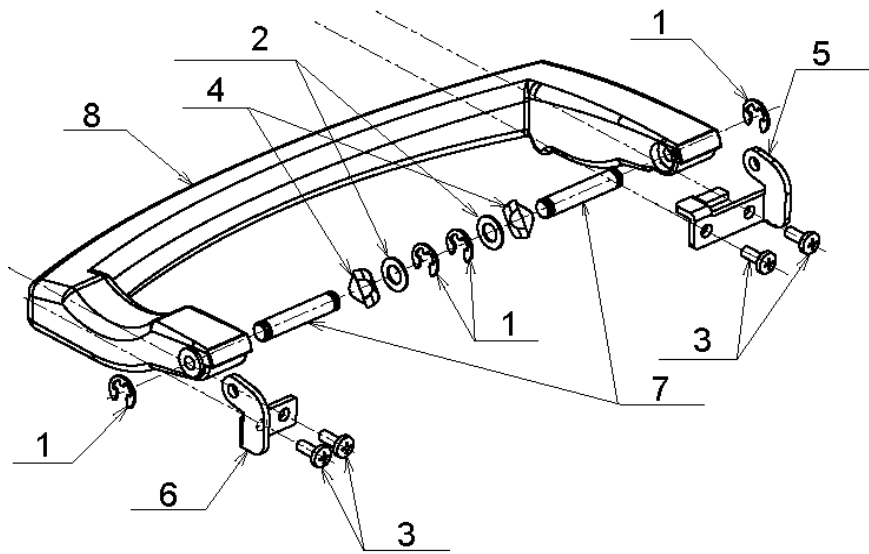

BUYER'S MODEL NO.	XL-550	SECTION	PAGE	REVISION	REMARKS
BUYER'S MODEL NAME	FUTURA		7		
FACTORY MODEL	235				
ORIGINAL ISSUE	JAN , 2010	SERIAL NO.			

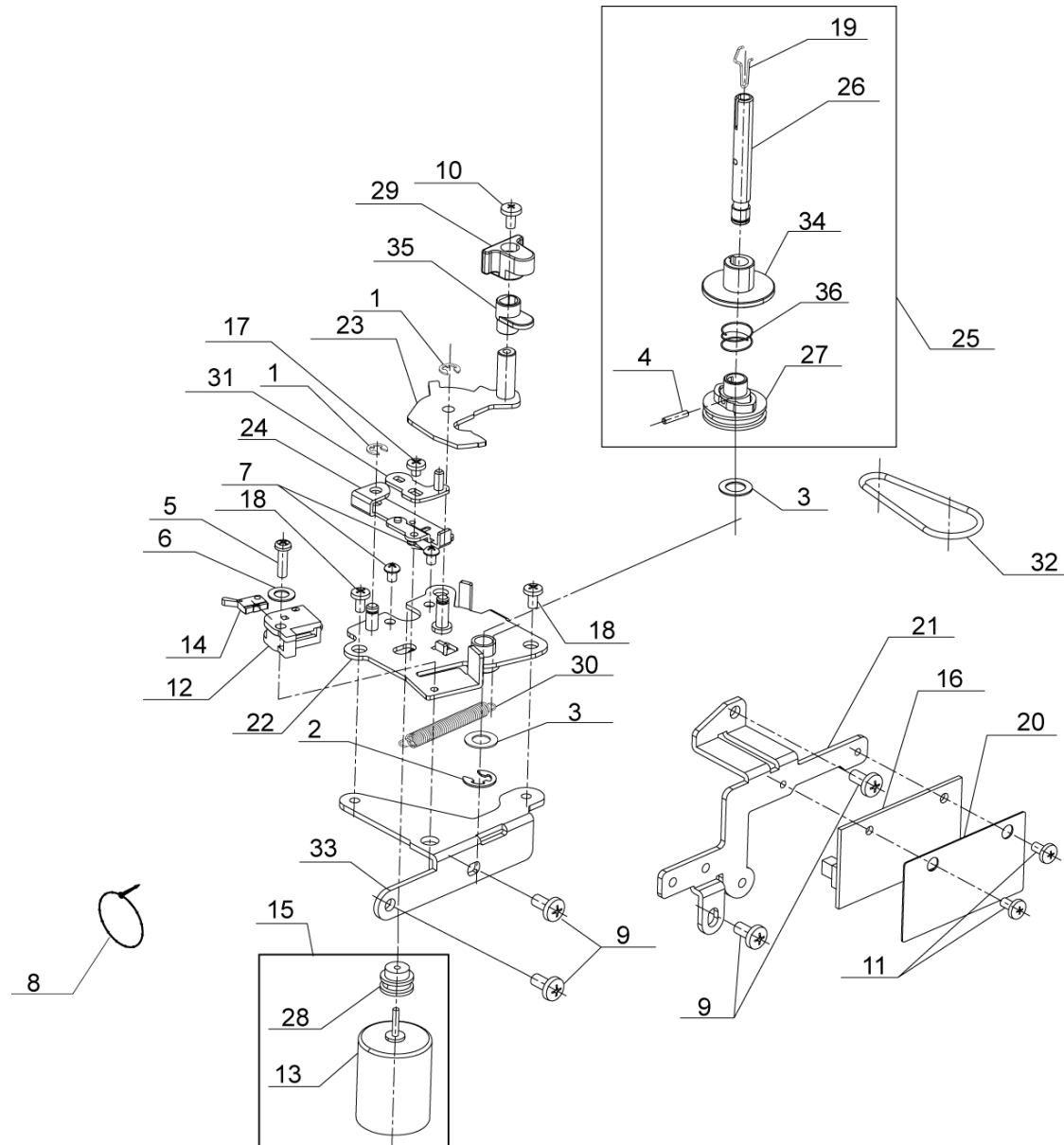

PAGE	NO.	PART NO.	DESCRIPTION
7	1	1520	E3 CLIP-ON-WASHER
7	2	8400	E5 CLIP-ON-WASHER
7	3	32316	WASHER
7	4	60162	KNOCK PIN
7	5	63796	M3 SCREW
7	6	63805	WASHER
7	7	73900	M3 PHILIPS SCREW
7	8	77041	UNITY FASTENER
7	9	77042	M4 PHILLIPS SCREW
7	10	77044	M3 PHILIPS SCREW
7	11	77053	M3 PHILIPS SCREW
7	12	77527	SENSOR COVER
7	13	85523	MOTOR FOR BOBBIN WINDER
7	14	85524	BOBBIN WINDER SWITCH HARNESS
7	15	85541	MOTOR FOR BOBBIN WINDER UNIT
7	16	85556	CAM SENSOR HARNESS
7	17	86376	M3 SCREW
7	18	87000	M4 SCREW
7	19	87190	SPRING
7	20	87242	INSULATION SHEET
7	21	89254	CAM SENSOR FIXING PLATE
7	22	89306	BOBBIN WINDER
7	23	89307	BOBBIN WINDER ARM
7	24	89308	BOBBIN WINDER SWITCH
7	25	89309	BOBBIN WINDER SHAFT UNIT
7	26	89310	BOBBIN WINDER SHAFT
7	27	89311	BOBBIN WINDER PULLEY
7	28	89313	BOBBIN WINDER MOTOR PULLEY
7	29	89314	BOBBIN WINDER CAM
7	30	89315	BOBBIN WINDER EXTENSION SPRING
7	31	89316	BOBBIN WINDER FOLLOWER
7	32	89317	ROUND BELT
7	33	89318	BOBBIN WINDING UNIT SUPPORT
7	34	89367	BOBBIN WINDING SWITCH LIMITER A
7	35	89368	BOBBIN WINDING SWITCH LIMITER B
7	36	89369	COMPRESSION SPRING

BUYER'S MODEL NO.	XL-550	SECTION		REVISION		REMARKS	
BUYER'S MODEL NAME	FUTURA		8				
FACTORY MODEL	235						
ORIGINAL ISSUE	JAN , 2010	SERIAL NO.					

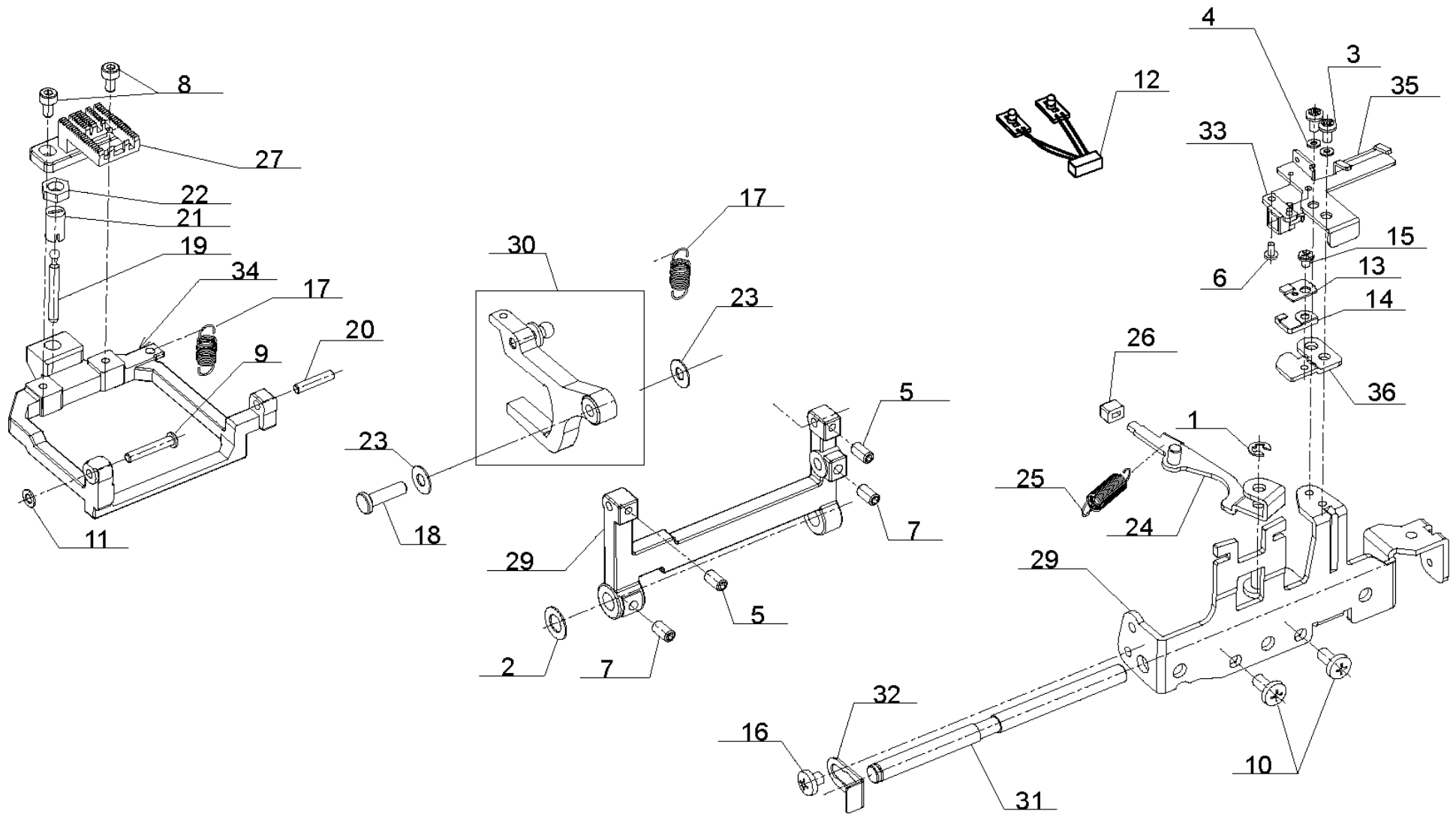

PAGE	NO.	PART NO.	DESCRIPTION
8	1	1520	E3 CLIP-ON-WASHER
8	2	32316	WASHER
8	3	43647	M3 SCREW
8	4	63805	WASHER
8	5	64653	M3 SCREW
8	6	66005	M2 PHILIPS SCREW
8	7	66725	M4 SCREW
8	8	72274	M3 CP SCREW
8	9	76132	SHAFT
8	10	77042	M4 PHILLIPS SCREW
8	11	85252	WASHER
8	12	85543	SENSOR HARNESS
8	13	86241	NEEDLE BAR THREAD GUIDE
8	14	86243	RETAINER PLATE
8	15	86244	RETAINER SET
8	16	87000	M4 SCREW
8	17	87186	TORSION SPRING
8	18	87206	PIN
8	19	87208	BALL HEADED PIN
8	20	87210	PIN
8	21	87232	M6 STUD SCREW
8	22	87268	M6 NUT
8	23	87269	WASHER
8	24	87423	DROP LEVER
8	25	87424	TORSION SPRING
8	26	87425	DROP KNOB
8	27	89221	FEED FOG
8	28	89223	FEED SECURING PLATE
8	29	89225	FEED DOG BASE SUPPORT
8	30	89226	FEED REGULATOR ARM UNIT
8	31	89241	FEED REGULATOR SHAFT
8	32	89246	SECURING PLATE
8	33	89250	FLOOD LIGHT HOLDER
8	34	89252	FEED DOG BASE
8	35	89255	SENSOR ATTACHMENT PLATE
8	36	89359	RETAINER

BUYER'S MODEL NO.	XL-550	SECTION		REVISION		REMARKS	
BUYER'S MODEL NAME	FUTURA		9				
FACTORY MODEL	235						
ORIGINAL ISSUE	JAN , 2010	SERIAL NO.					

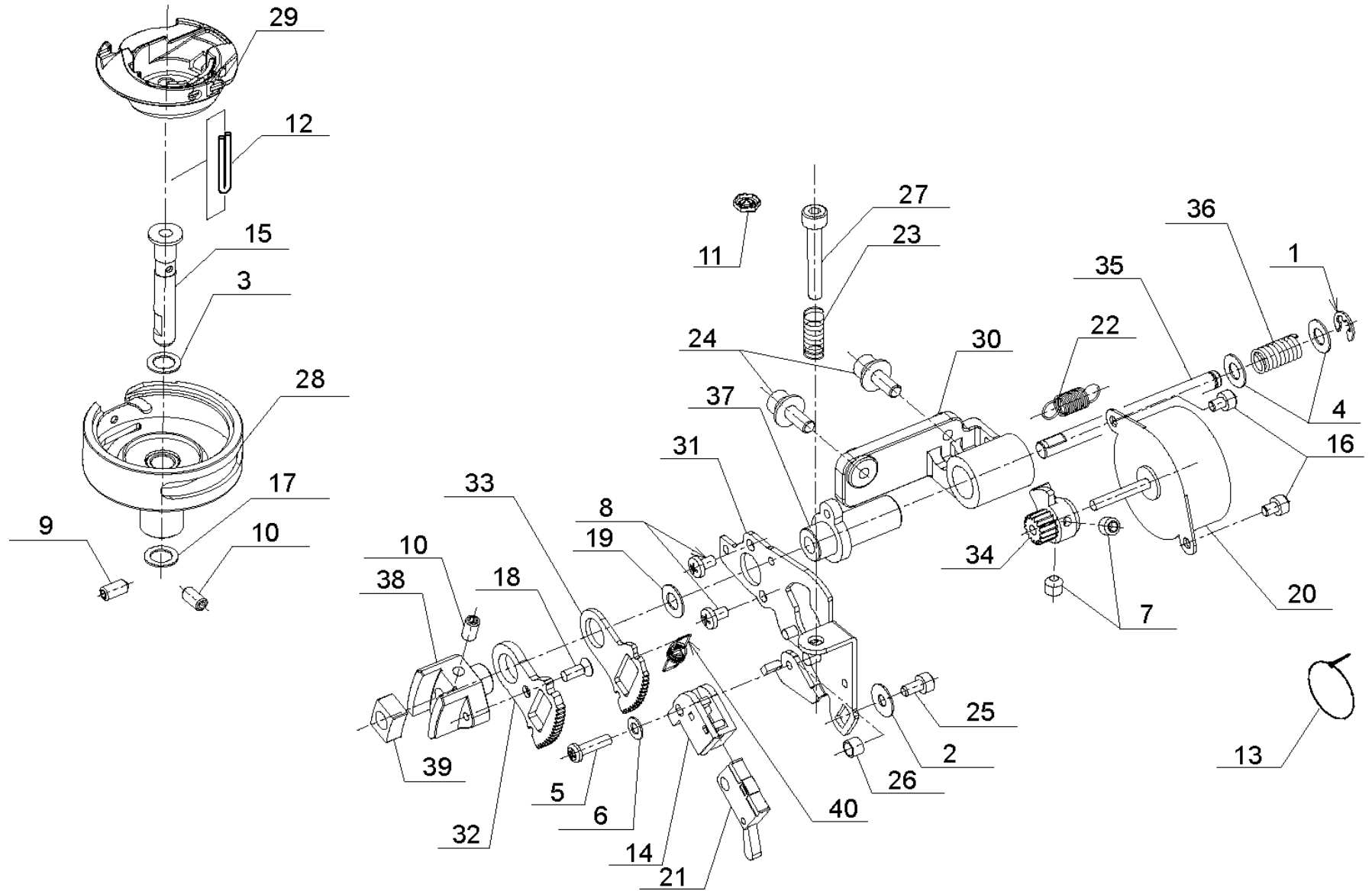

PAGE	NO.	PART NO.	DESCRIPTION
9	1	1513	E4 CLIP-ON-WASHER
9	2	31246	WASHER
9	3	43392	THRUST WASHER
9	4	59221	WASHER
9	5	63796	M3 SCREW
9	6	63805	WASHER
9	7	64653	M3 SCREW
9	8	66318	M3 PHILIPS SCREW
9	9	66725	M4 SCREW
9	10	66727	M4 SCREW
9	11	73299	M4 TORQUE NUT
9	12	76203	OILING CORD
9	13	77041	UNITY FASTENER
9	14	77527	SENSOR COVER
9	15	80078	SHUTTLE RACE SHAFT
9	16	80110	BOLT
9	17	80752	WASHER
9	18	85072	M3 SCREW
9	19	85162	WASHER
9	20	85522	STEPPING MOTOR
9	21	85528	STEPPING MOTOR HARNESS (FEEDING)
9	22	87188	SPRING
9	23	87189	COMPRESSION SPRING
9	24	87261	CP BOLT
9	25	87262	M3 CP SCREW
9	26	87273	PIN
9	27	87668	M4 BOLT
9	28	89202	SHUTTLE RACE UNIT
9	29	89210	BOBBIN CASE UNIT
9	30	89229	FEED REGULATOR SUPPORT
9	31	89230	PM SUPPORT
9	32	89231	FEED REGULATOR BLOCK GEAR A
9	33	89232	FEED REGULATOR BLOCK GEAR B
9	34	89233	PINION (16T) UNIT
9	35	89235	FEED REGULATOR SHAFT
9	36	89236	FEED REGULATOR SPRING
9	37	89237	FEED REGULATOR BUSH
9	38	89239	FEED REGULATOR
9	39	89240	SLIDE BLOCK
9	40	89393	FEED REGULATOR GEAR SPRING

BUYER'S MODEL NO.	XL-550	SECTION		PAGE		REVISION		REMARKS	
BUYER'S MODEL NAME	FUTURA			10					
FACTORY MODEL	235								
ORIGINAL ISSUE	JAN , 2010				SERIAL NO.				

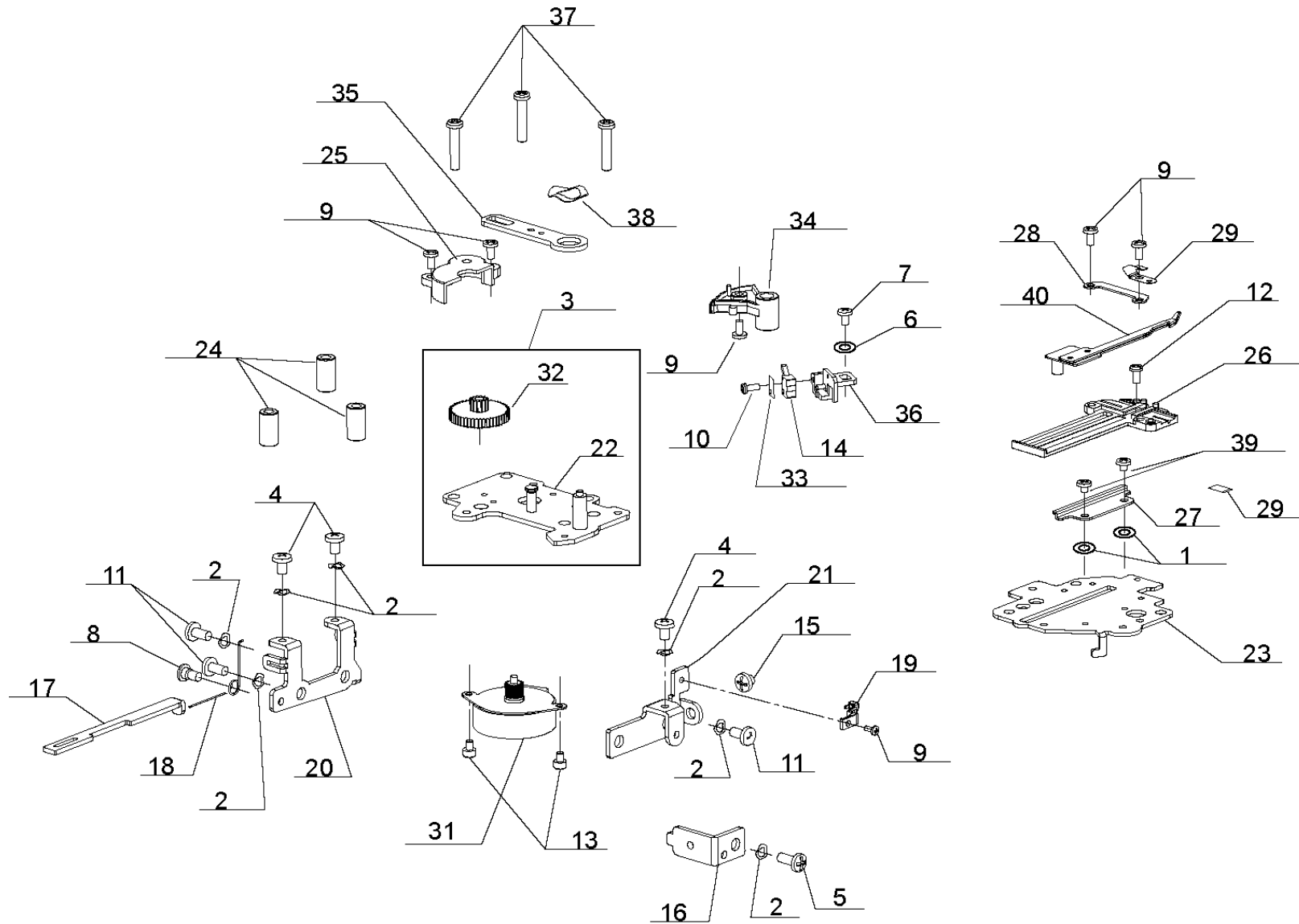

PAGE	NO.	PART NO.	DESCRIPTION
10	1	37515	WASHER
10	2	45704	CRINKLE WASHER
10	3	52091	THREAD CUTTER BASE SET
10	4	61222	M4 PHILIPS SCREW
10	5	63560	M4 PHILIPS SCREW
10	6	64360	WASHER
10	7	66318	M3 PHILIPS SCREW
10	8	66481	M4 STUD SCREW
10	9	76317	M3 PHILIPS SCREW
10	10	76729	TAPPING SCREW
10	11	77042	M4 PHILLIPS SCREW
10	12	77044	M3 PHILIPS SCREW
10	13	80110	BOLT
10	14	85538	SENSOR HARNESS
10	15	87000	M4 SCREW
10	16	89215	MOUNTING PLATE
10	17	89247	DROP CONNECTING PLATE
10	18	89248	TORSION SPRING
10	19	89251	SENSOR RECEIVER HOLDER
10	20	89335	BLADE FIXTURE
10	21	89336	THREAD CUTTER BASE B
10	22	89337	THREAD CUTTER BASE C
10	23	89338	THREAD CUTTER BASE D
10	24	89339	PIPE BASE
10	25	89340	GEAR COVER
10	26	89341	THREAD CUTTER GUIDE PLATE
10	27	89342	GUIDE PLATE
10	28	89343	HOOK SECURING PLATE
10	29	89344	THREAD CUTTER SPRING PLATE
10	30	89345	BLADE
10	31	89346	THREAD CUTTER STEPPING MOTOR
10	32	89347	THREAD CUTTER GEAR
10	33	89348	INSULATION SHEET
10	34	89349	THREAD CUTTER LEVER GEAR
10	35	89350	THREAD CUTTER DRIVING LEVER
10	36	89358	BOBBIN THREAD CUTTER SWITCH BASE
10	37	89360	M4 SCREW
10	38	89361	CRINKLE WASHER
10	39	89376	M3 SCREW
10	40	89428	THREAD CUTTER HOOK UNIT

BUYER'S MODEL NO.	XL-550	SECTION		PAGE		REVISION		REMARKS	
BUYER'S MODEL NAME	FUTURA			11					
FACTORY MODEL	235								
ORIGINAL ISSUE	JAN , 2010					SERIAL NO.			

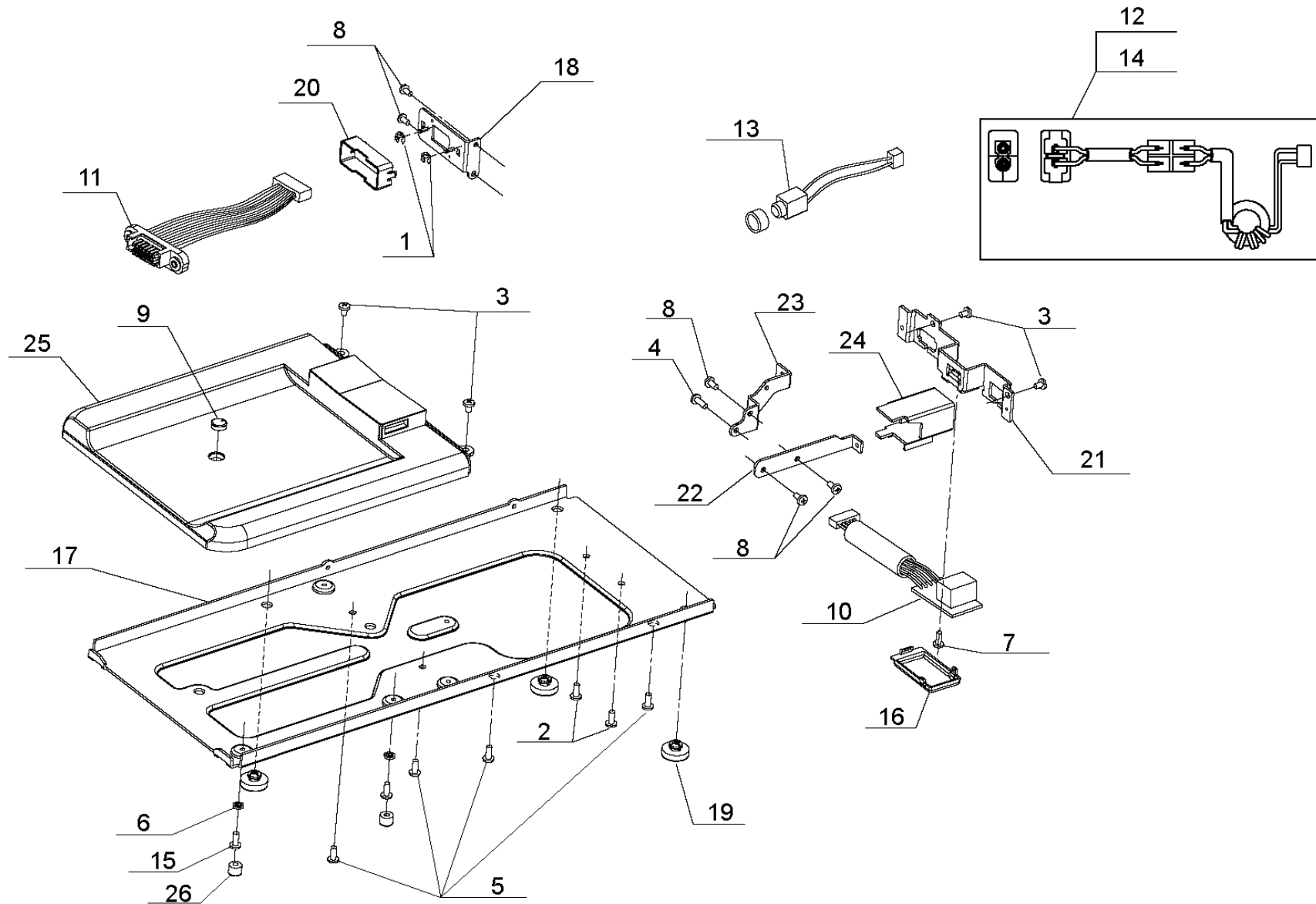

BUYER'S MODEL NO.	XL-550	SECTION		PAGE		REVISION		REMARKS	
BUYER'S MODEL NAME	FUTURA			12					
FACTORY MODEL	235								
ORIGINAL ISSUE	JAN , 2010		SERIAL NO.						

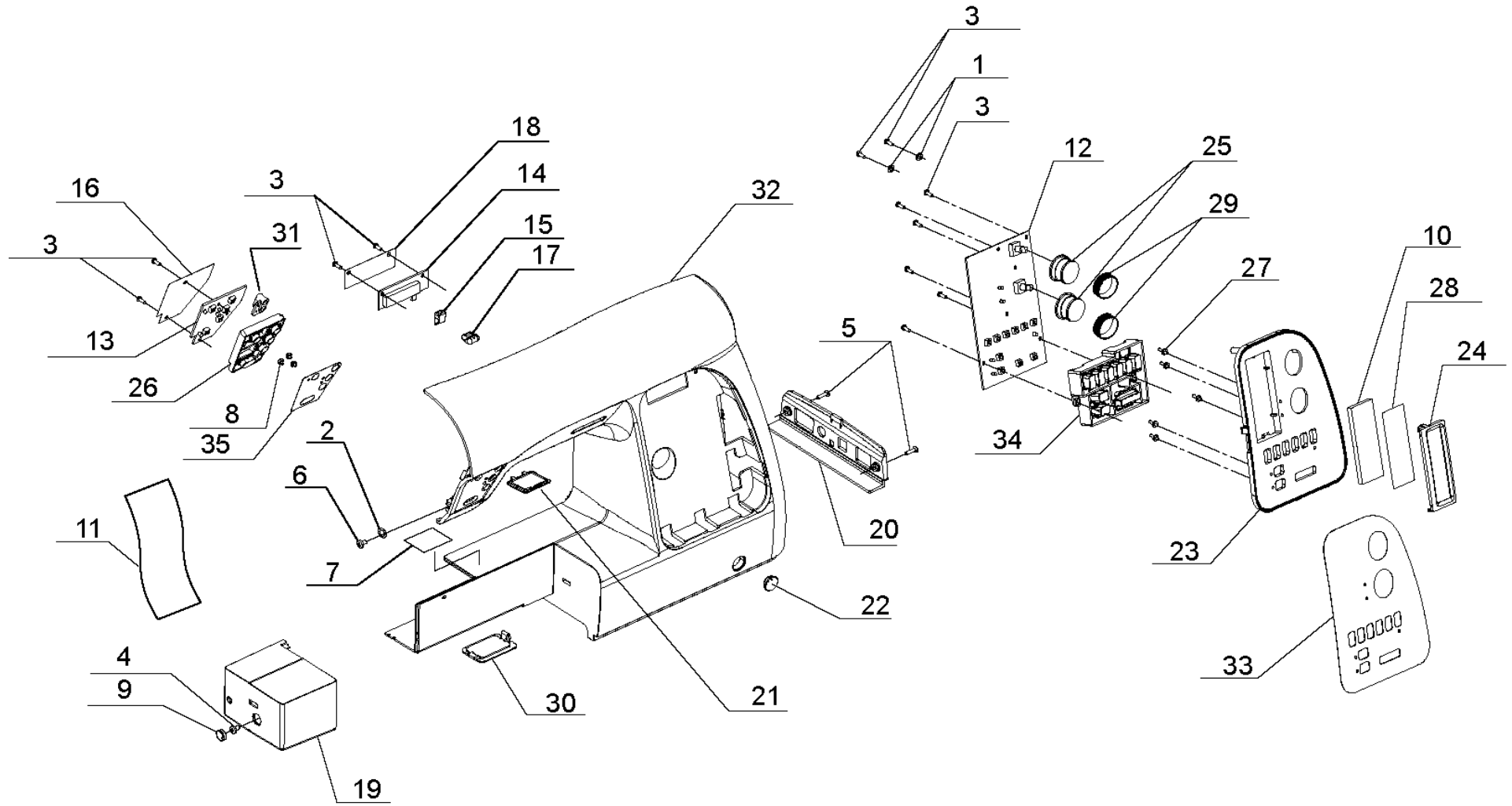

PAGE	NO.	PART NO.	DESCRIPTION
12	1	25670	WASHER
12	2	31246	WASHER
12	3	39213	M3 SCREW
12	4	61222	M4 PHILIPS SCREW
12	5	64973	M3 PHILIPS SCREW
12	6	76317	M3 PHILIPS SCREW
12	7	76511	SEAL
12	8	83044	LED PANEL
12	9	83116	CAP
12	10	85517	LCD
12	11	85521	CONNECTOR CABLE
12	12	85535	SWITCH CIRCUIT BOARD
12	13	85547	SW HARNESS
12	14	85549	SPEED CONTROL SWITCH HARNESS
12	15	87804	SLIDE LEVER
12	16	89373	INSULATION SHEET (SW HARNESS)
12	17	89374	SPEED CONTROL KNOB
12	18	89376	INSULATION SHEET (SV BOARD HARNESS)
12	19	89403	BED CAP
12	20	89404	TERMINAL COVER
12	21	89409	LED LIGHT COVER
12	22	89410	KNEE LIFTER CAP
12	23	89411	CONTROL PANEL
12	24	89413	LCD CASE
12	25	89416	BUTTON
12	26	89417	SWITCH PANEL BUTTON
12	27	89418	LED LENS
12	28	89420	LCD PROTECTION SHEET
12	29	89425	RUBBER BAND
12	30	89458	STEPPING MOTOR ADJUST COVER
12	31	89460	LED SHADE PLATE
12	32	89482	FRONT COVER
12	33	89484	PANEL SHEET
12	34	89485	SWITCH PANEL BUTTON
12	35	89491	SWITCH PANEL SHEET

BUYER'S MODEL NO.	XL-550	SECTION		PAGE		REVISION		REMARKS	
BUYER'S MODEL NAME	FUTURA			13					
FACTORY MODEL	235								
ORIGINAL ISSUE	JAN , 2010		SERIAL NO.						

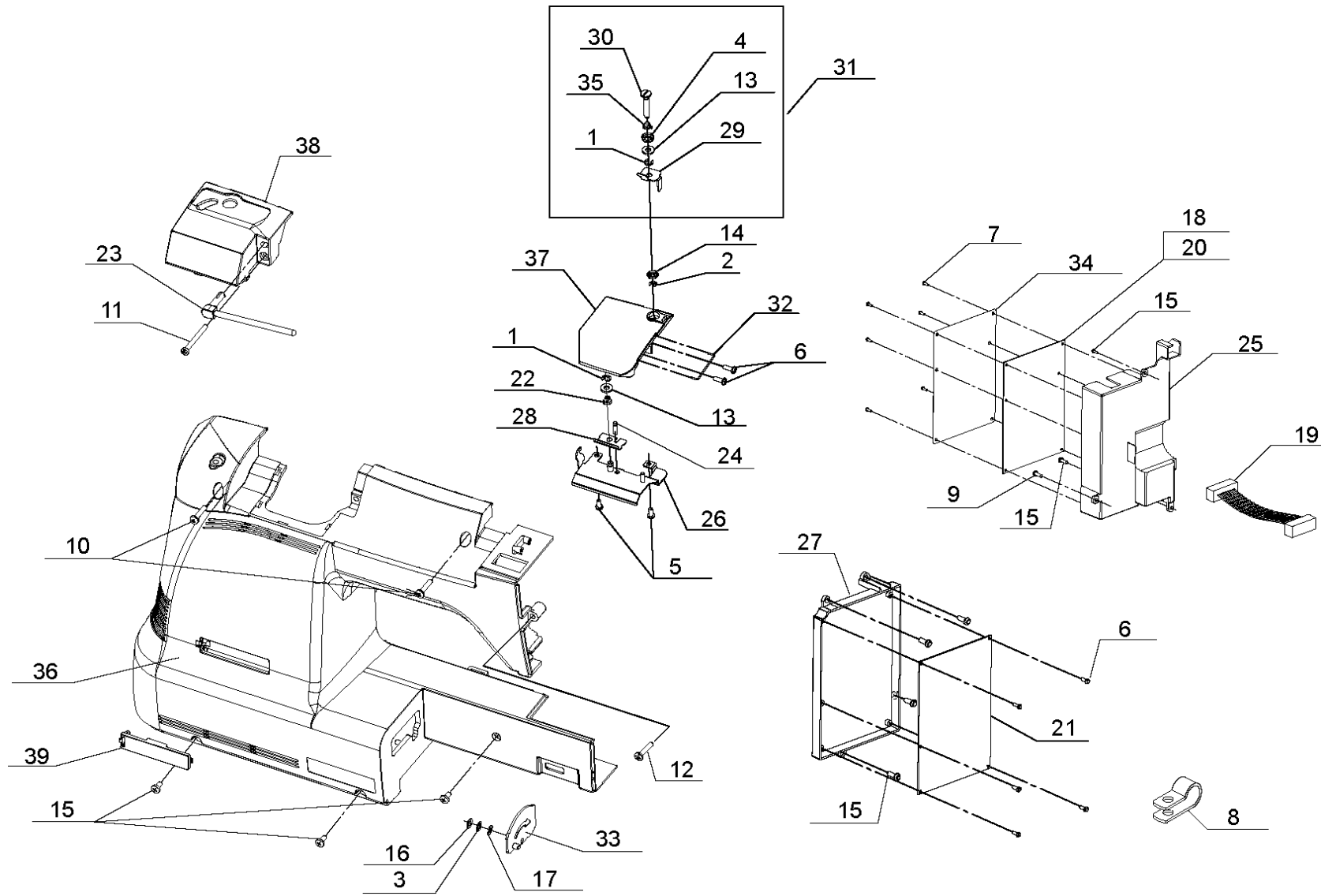

PAGE	NO.	PART NO.	DESCRIPTION
13	1	1520	E3 CLIP-ON-WASHER
13	2	27925	E2.5 CLIP-ON-WASHER
13	3	32949	WASHER
13	4	38706	HOLDER TENSION DISC
13	5	39163	TAPPING SCREW
13	6	39213	M3 SCREW
13	7	47181	TAPPING SCREW
13	8	58741	CORD GUARD
13	9	61225	M4 PHILIPS SCREW
13	10	64484	TAPPING SCREW
13	11	64957	TAPPING SCREW
13	12	65736	M4 PHILIPS SCREW
13	13	72858	WASHER
13	14	73299	M4 TORQUE NUT
13	15	77042	M4 PHILLIPS SCREW
13	16	77507	CLIP-ON-WASHER
13	17	85080	CRINKLE WASHER
13	18	85525	AC CIRCUIT BOARD (100-120V)
13	19	85526	CONNECTOR CABLE
13	20	85545	AC CIRCUIT BOARD (200-240V)
13	21	85580	CPU CIRCUIT BOARD
13	22	86999	SPRING
13	23	87296	SPOOL PIN UNIT
13	24	88332	PIN
13	25	89249	AC CIRCUIT BOARD BOX
13	26	89327	THREAD GUIDE
13	27	89370	CPU CIRCUIT BOARD BOX
13	28	89377	THREAD REGULATING PLATE
13	29	89379	THREAD GUIDE BASE
13	30	89380	THREAD GUIDE ADJUSTABLE SCREW
13	31	89381	THREAD GUIDE UNIT
13	32	89383	THREAD GUIDE PIN
13	33	89407	DRAWER CAP
13	34	89424	INSULATION SHEET (AC CIRCUIT)
13	35	89427	COMPRESSION SPRING
13	36	89444	BACK COVER
13	37	89445	THREAD PATH CAP
13	38	89446	BOBBIN WINDER COVER
13	39	89448	SPOOL STAND ATTACHMENT COVER

BUYER'S MODEL NO.	XL-550	SECTION	PAGE	REVISION	REMARKS
BUYER'S MODEL NAME	FUTURA		14		
FACTORY MODEL	235				
ORIGINAL ISSUE	JAN , 2010	SERIAL NO.			

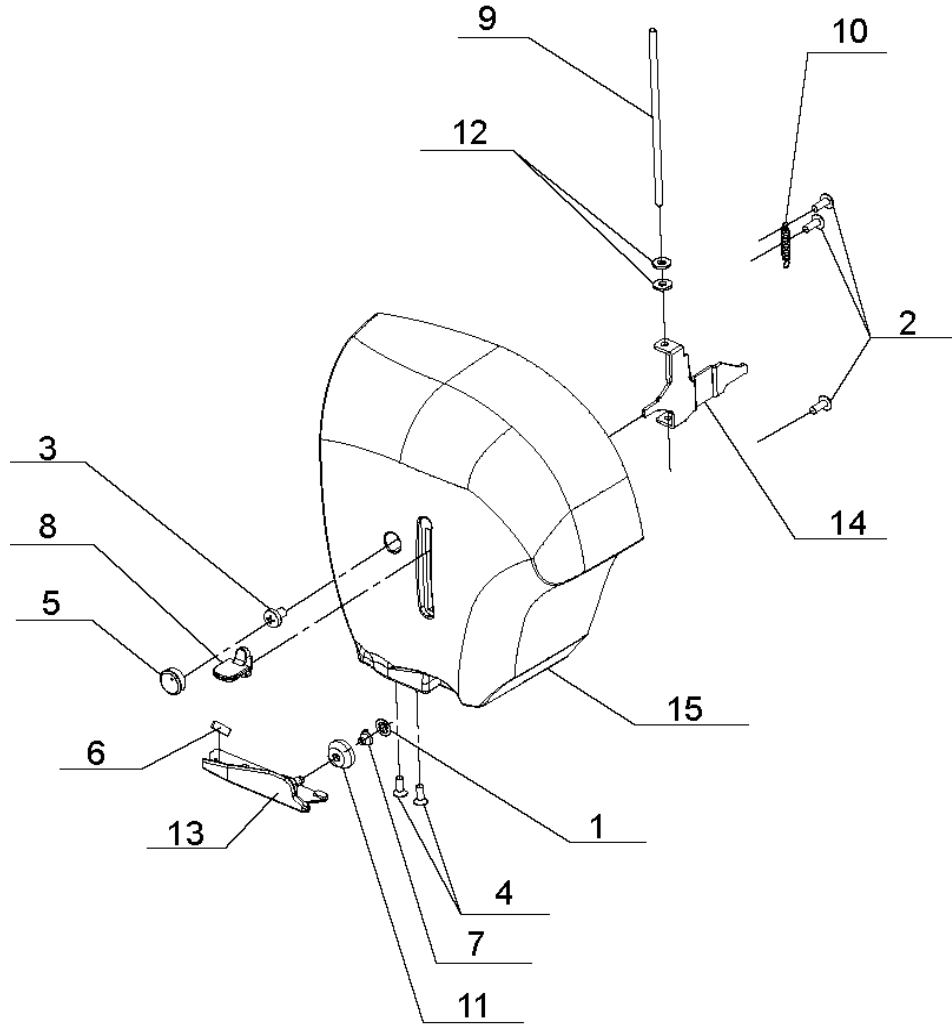

BUYER'S MODEL NO.	XL-550	SECTION		PAGE		REVISION		REMARKS	
BUYER'S MODEL NAME	FUTURA			15					
FACTORY MODEL	235								
ORIGINAL ISSUE	JAN , 2010		SERIAL NO.						

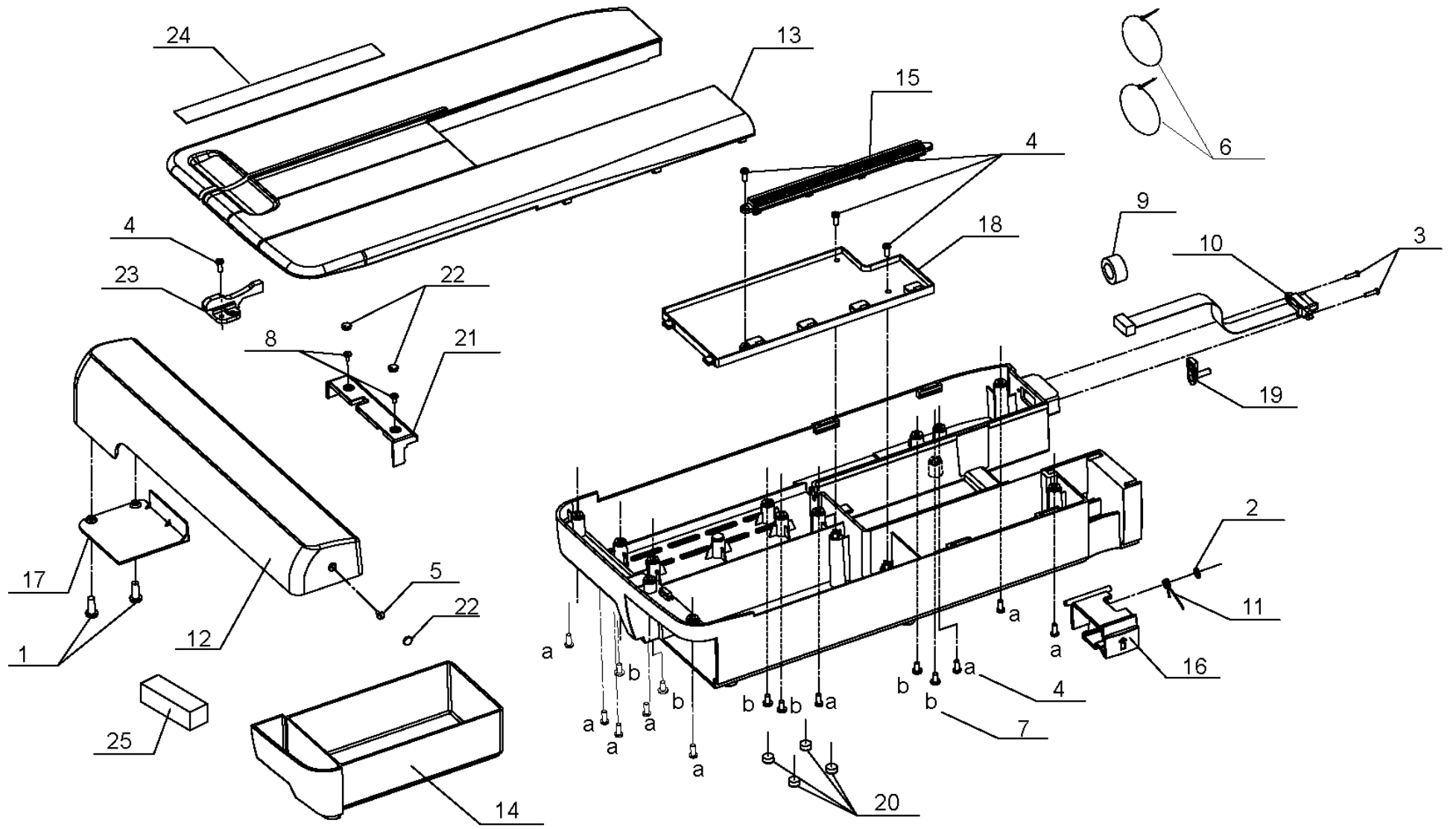

BUYER'S MODEL NO.	XL-550	SECTION		PAGE		REVISION		REMARKS	
BUYER'S MODEL NAME	FUTURA			16					
FACTORY MODEL	235								
ORIGINAL ISSUE	JAN , 2010		SERIAL NO.						

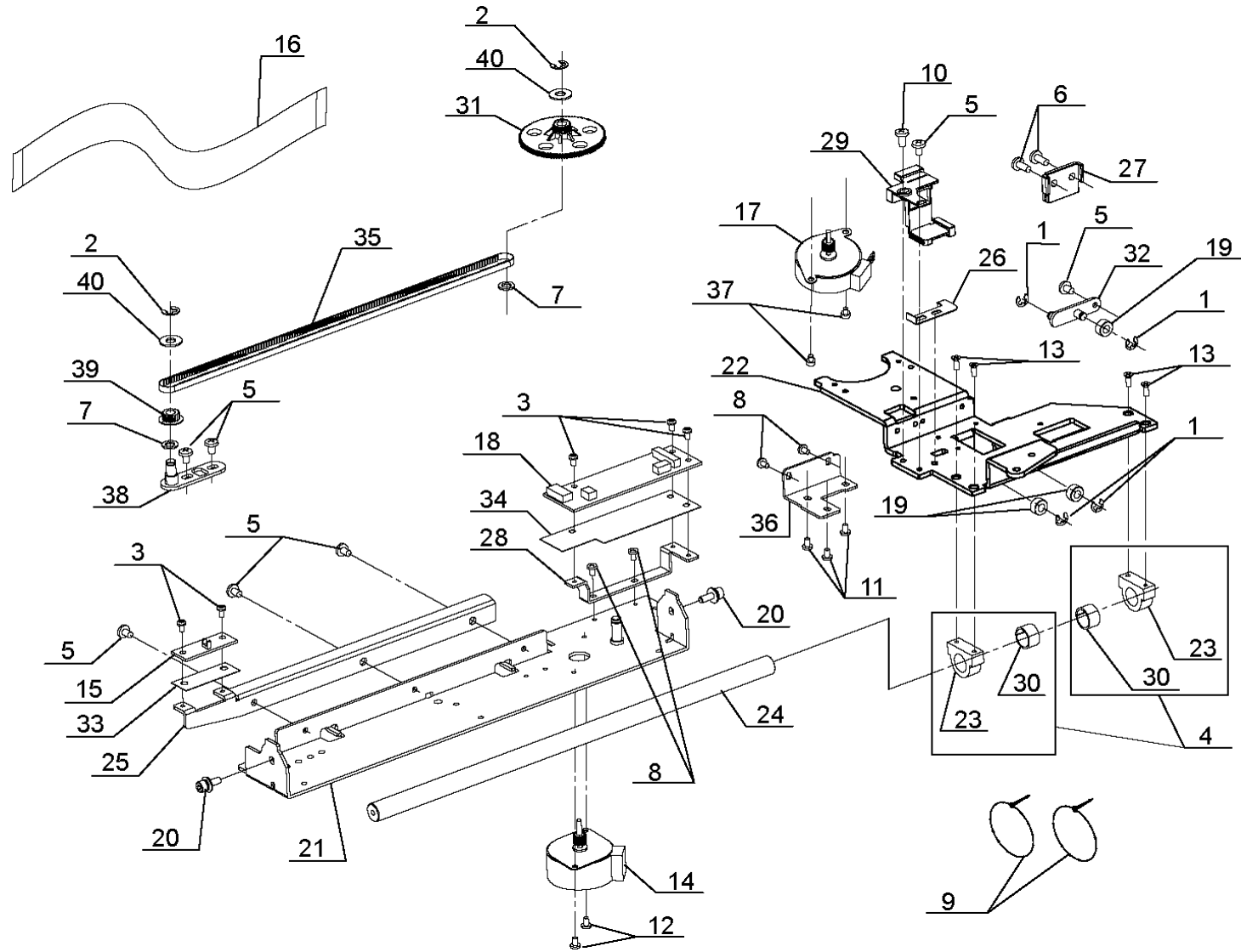

PAGE	NO.	PART NO.	DESCRIPTION
16	1	1513	E4 CLIP-ON-WASHER
16	2	8400	E5 CLIP-ON-WASHER
16	3	43647	M3 SCREW
16	4	52095	X AXIS METAL BUSH
16	5	61222	M4 PHILIPS SCREW
16	6	61224	M4 PHILIPS SCREW
16	7	61592	WASHER
16	8	66318	M3 PHILIPS SCREW
16	9	77041	UNITY FASTENER
16	10	77042	M4 PHILLIPS SCREW
16	11	77044	M3 PHILIPS SCREW
16	12	80110	BOLT
16	13	85072	M3 SCREW
16	14	85560	X AXIS MOTOR
16	15	85561	X AXIS SENSOR HARNESS
16	16	85562	X AXIS FFC CORD
16	17	85565	Y AXIS MOTOR
16	18	85568	X AXIS MAIN BOARD
16	19	86349	GUIDE ROLLER
16	20	87261	CP BOLT
16	21	89507	X BASE
16	22	89508	X MOVING PLATE
16	23	89509	X AXIS METAL
16	24	89510	X AXIS SHAFT
16	25	89511	X AXIS RAIL PLATE
16	26	89512	X AXIS DOG ADJUSTING PLATE
16	27	89513	X AXIS BELT HOLDER
16	28	89517	JOINING HARNESS SUPPORT
16	29	89518	F CABLE HOLDER
16	30	89519	X AXIS BUSH
16	31	89520	DRIVING PULLEY
16	32	89521	X AXIS ROLLER SUPPORT
16	33	89523	INSULATION SHEET
16	34	89524	INSULATION SHEET
16	35	89526	X AXIS TIMING BELT
16	36	89527	X AXIS MOVING PLATE SUPPORT
16	37	89536	CP SCREW
16	38	89566	PULLEY BASE
16	39	89567	PULLEY
16	40	89568	WASHER

BUYER'S MODEL NO.	XL-550	SECTION		PAGE		REVISION		REMARKS	
BUYER'S MODEL NAME	FUTURA			17					
FACTORY MODEL	235								
ORIGINAL ISSUE	JAN , 2010		SERIAL NO.						

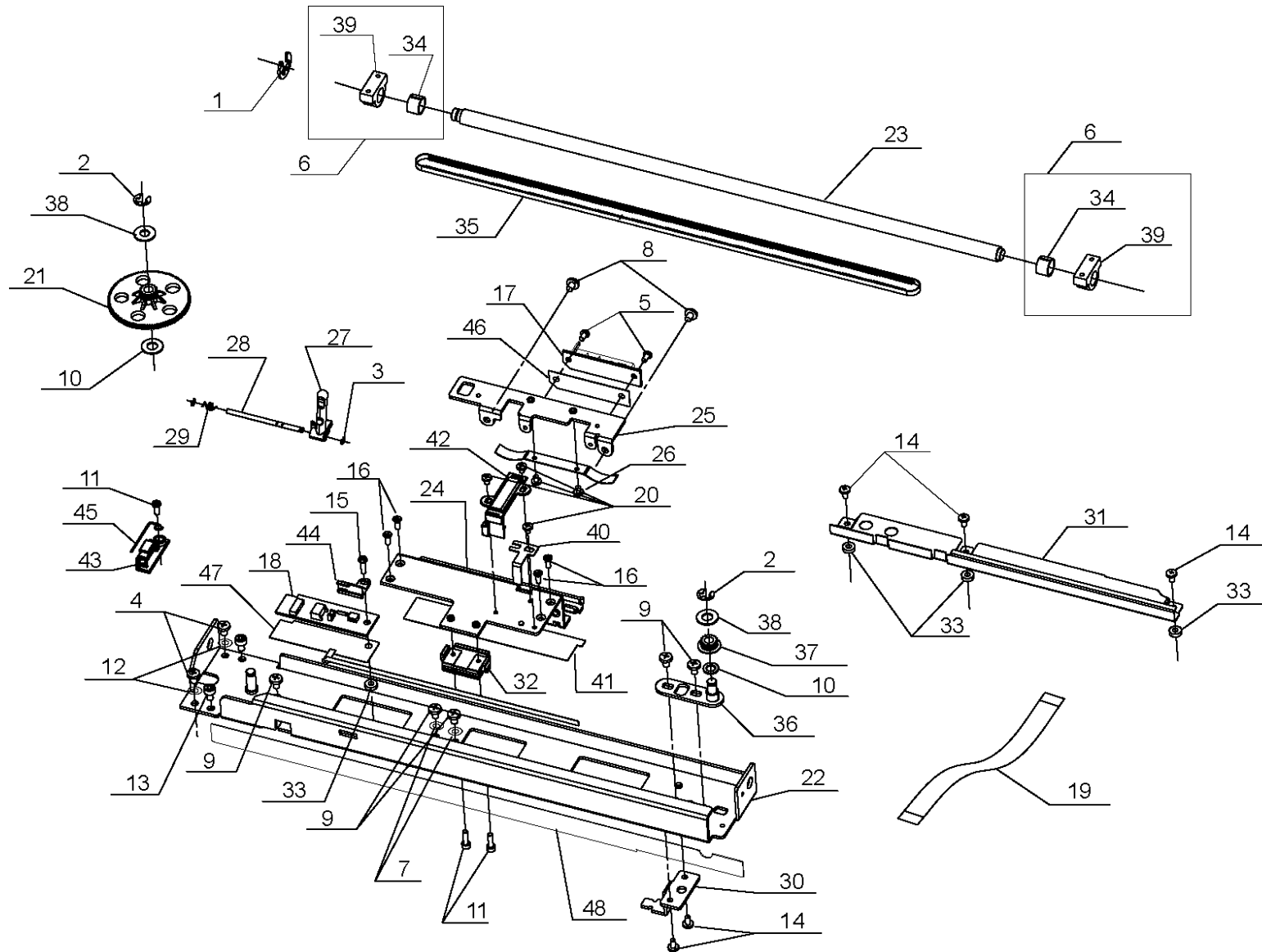

PAGE	NO.	PART NO.	DESCRIPTION
17	1	1504	E7 CLIP-ON-WASHER
17	2	8400	E5 CLIP-ON-WASHER
17	3	25436	E2 CLIP-ON-WASHER
17	4	31733	M3 NUT
17	5	43647	M3 SCREW
17	6	52096	Y AXIS METAL BUSH
17	7	58220	WASHER
17	8	61221	M4 PHILIPS SCREW
17	9	61222	M4 PHILIPS SCREW
17	10	61592	WASHER
17	11	63796	M3 SCREW
17	12	63805	WASHER
17	13	72367	M4 CP SCREW
17	14	77053	M3 PHILIPS SCREW
17	15	77057	M3 PHILIPS SCREW
17	16	85072	M3 SCREW
17	17	85563	SENSOR HARNESS
17	18	85566	Y AXIS SENSOR HARNESS
17	19	85567	Y AXIS FFC CORD
17	20	87256	M3 SCREW
17	21	89520	DRIVING PULLEY
17	22	89550	Y AXIS BASE
17	23	89551	Y AXIS SHAFT
17	24	89553	Y AXIS MOVING PLATE
17	25	89554	SWITCH HARNESS SUPPORT
17	26	89556	HOOP HOLDER SPRING PLATE
17	27	89557	HOOP FIXING LEVER
17	28	89558	HOOP FIXING LEVER SHAFT
17	29	89559	HOOP FIXING LEVER SPRING
17	30	89560	X AXIS RAIL GUIDE SUPPORT
17	31	89561	F CABLE GUIDE PLATE
17	32	89562	Y AXIS RAIL GUIDE SUPPORT
17	33	89563	SPACER
17	34	89564	Y AXIS BUSH
17	35	89565	Y AXIS TIMING BELT
17	36	89566	PULLEY BASE
17	37	89567	PULLEY
17	38	89568	WASHER
17	39	89569	Y AXIS METAL
17	40	89570	Y AXIS DOG ADJUSTING PLATE
17	41	89571	PROTECTION STICKER
17	42	89580	F CABLE HOLDER A
17	43	89581	F CABLE HOLDER B
17	44	89582	F CABLE HOLDER C
17	45	89585	F CABLE GUIDE
17	46	89586	INSULATION SHEET
17	47	89587	INSULATION SHEET
17	48	89589	Y AXIS BASE SHEET

BUYER'S MODEL NO.	XL-550	SECTION	PAGE	REVISION	REMARKS
BUYER'S MODEL NAME	FUTURA		18		
FACTORY MODEL	235				
ORIGINAL ISSUE	JAN , 2010	SERIAL NO.			

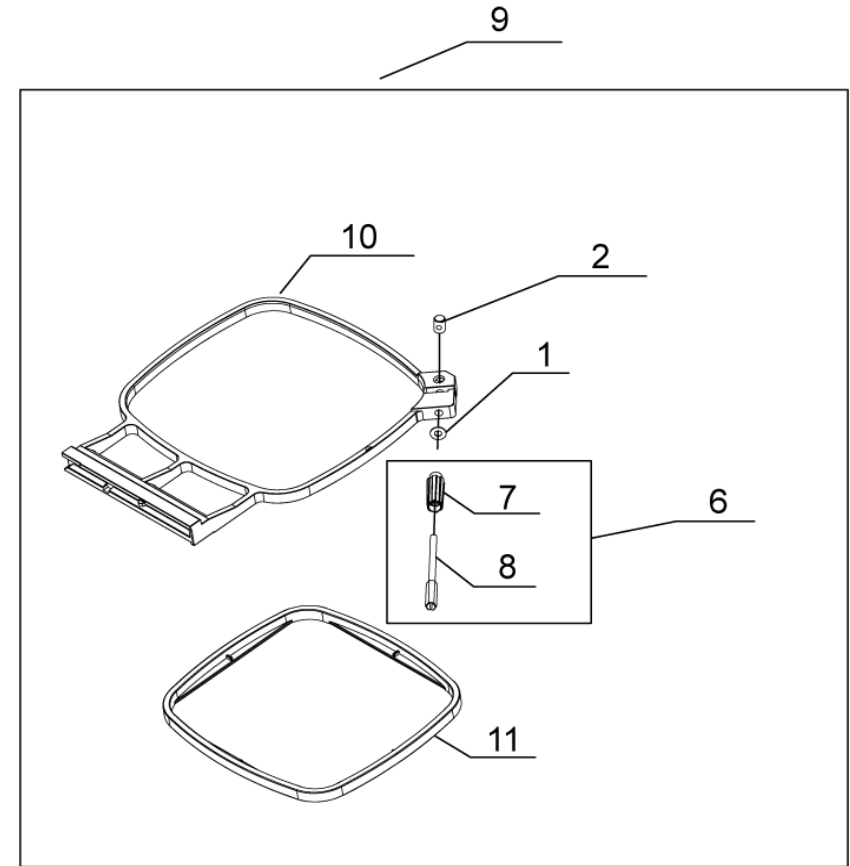
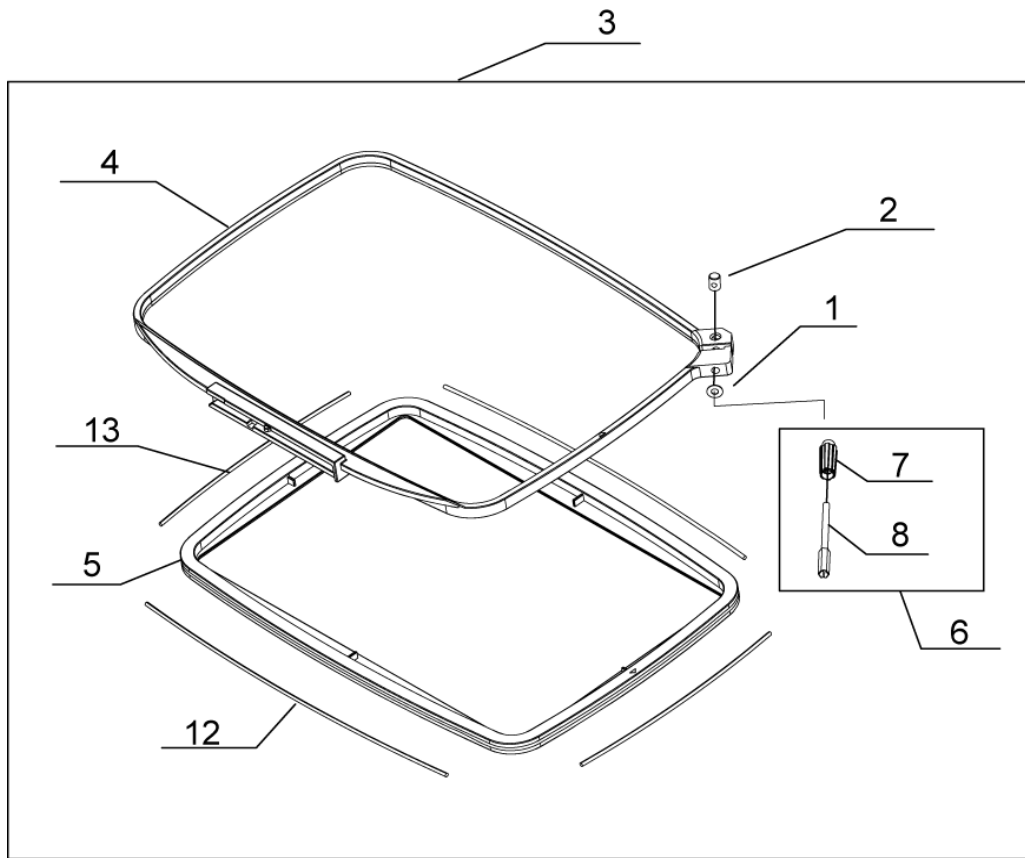

BUYER'S MODEL NO.	XL-550	SECTION		PAGE		REVISION		REMARKS	
BUYER'S MODEL NAME	FUTURA			19					
FACTORY MODEL	235								
ORIGINAL ISSUE	JAN , 2010		SERIAL NO.						

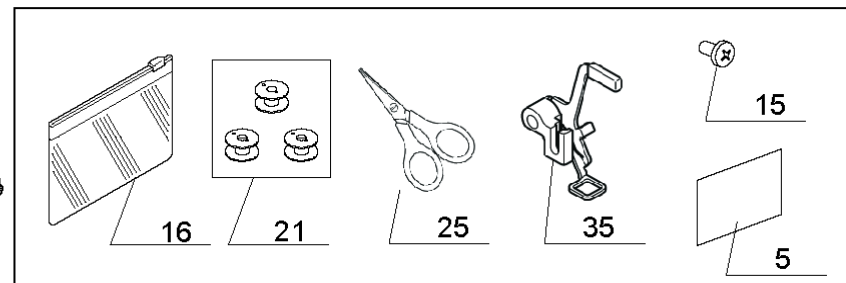
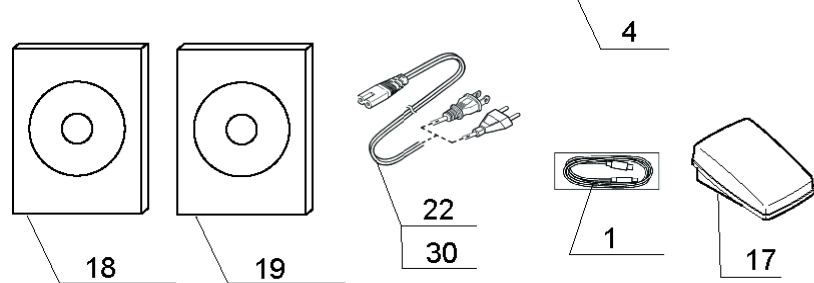
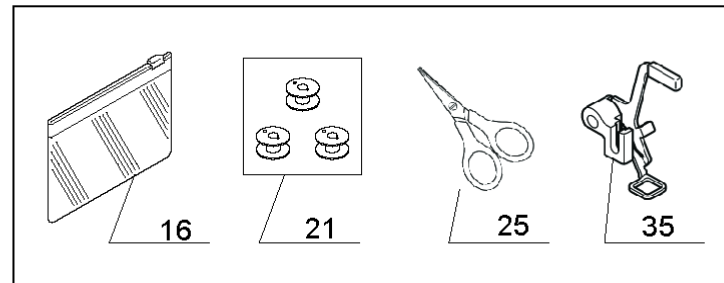
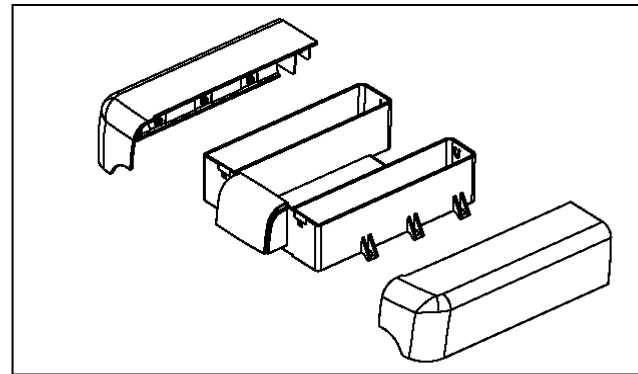
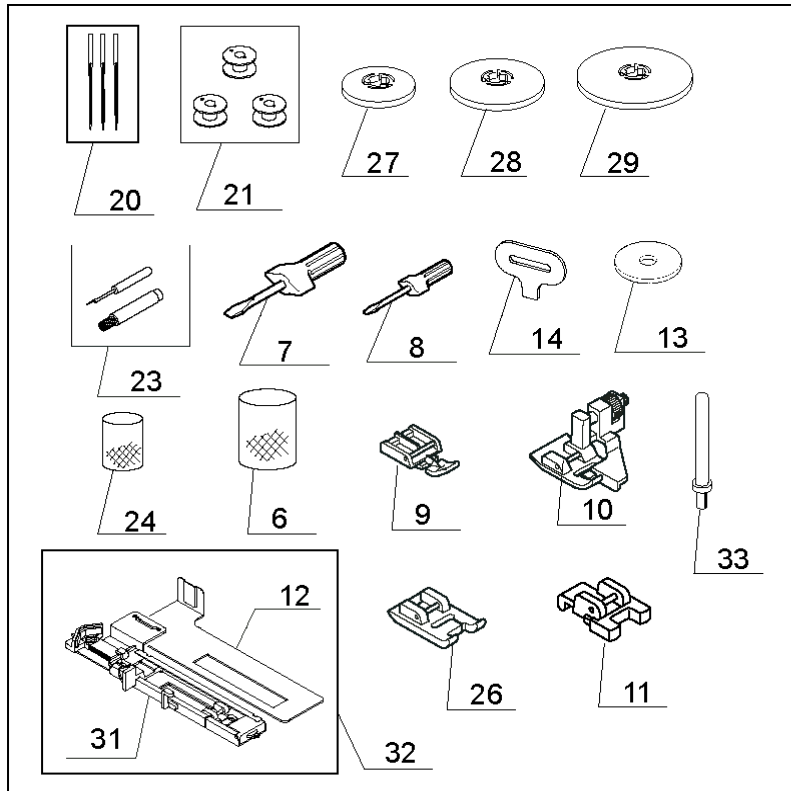

PAGE	PART NO.	DESCRIPTION
19	1	52092 USB CABLE
19	2	52119 ACCESSORY SET
19	3	52120 ACCESSORY SET (ITALY ONLY)
19	4	52121 ACCESSORY SET
19	5	62644 INSTRODUCTION SEEAT
19	6	63523 THREAD SPOOL NET (LONG)
19	7	65811 LARGE SCREW DRIVER
19	8	74793 SMALL SCREW DRIVER
19	9	76252 ZIPPER FOOT
19	10	76255 BLIND STITCH FOOT
19	11	76257 BUTTON SEWING FOOT
19	12	76630 BUTTONHOLE PLATE
19	13	77040 SPOOL PIN DISC
19	14	79455 LARGE SCREW DRIVER
19	15	80065 #7 SCREW FOR SHANK
19	16	80120 ACCESSORY VINYL BAG
19	17	81485 FOOT CONTROL
19	18	82460 INSTRODUCTION CD
19	19	82461 SOFTWARE CD
19	20	83123 NEEDLE SET
19	21	85128 BOBBIN
19	22	85339 POWER CORD (230V)
19	23	85365 BUTTONHOLE OPENER / BRUSH
19	24	86933 THREAD SPOOL NET (SHORT)
19	25	87003 SCISSORS
19	26	87275 SATIN FOOT
19	27	87287 SPOOL PIN CAP (MINI)
19	28	87289 SPOOL PIN CAP (SMALL)
19	29	87290 SPOOL PIN CAP (LARGE)
19	30	87534 POWER CORD (120V)
19	31	87696 BUTTONHOLE FOOT
19	32	88100 BUTTONHOLE FOOT
19	33	88366 SPOOL PIN
19	34	89487 ACCESSORY BOX
19	35	89672 EMBROIDERY PRESSER FOOT