

evolve

*Instruction and
Reference Guide*

Model BLE8-2

baby lock

"IMPORTANT SAFETY INSTRUCTIONS"

When using overlock machine, basic safety precautions should always be followed, including the following.

"Read all instructions before using this overlock machine."

DANGER- To reduce the risk of electric shock.

1. The overlock machine should never be left unattended when plugged in. Always unplug this overlock machine from the electrical outlet immediately after using and before cleaning.
2. Always unplug before replacing light bulb. Replace bulb with same type rated 15 watts/110 volts in 110V/120V area. (15 watts 240 volts in 220/240V area.)

WARNING- To reduce the risk of burns, fire, electric shock, or injury to persons.

1. Use this overlock machine only for its intended use as described in this manual. Use only attachments recommended by the manufacturer as contained in this manual.
2. Never operate this overlock machine if it has a damaged cord or plug, if it is not working properly, if it has been dropped or damaged, or dropped into water. Return the overlock machine to the nearest authorized dealer or service center for examination, repair, electrical or mechanical adjustment.
3. Never operate the overlock machine with any air openings blocked. Keep ventilation openings of the overlock machine and foot controller free from the accumulation of lint, dust, and loose cloth.
4. Never drop or insert any object into any opening.
5. Do not use outdoors.
6. Do not operate where aerosol (spray) products are being used or where oxygen is being administered.
7. To disconnect, turn the main switch to the symbol "O" position which represents off, then remove plug from outlet.
8. Do not unplug by pulling on cord. To unplug, grasp the plug, not the cord.
9. Keep fingers away from all moving parts. Special care is required around the overlock machine needle.
10. Always use the proper needle plate. The wrong needle plate can cause the needle to break.
11. Do not use bent needles.
12. Do not pull or push fabric while stitching. It may deflect the needle(s) causing it to break.
13. Switch the overlock machine to the symbol "O" position when making any adjustments in the needle area, such as threading needle, changing needle, threading looper, or changing presser foot, and the like.
14. Always unplug the overlock machine from the electrical outlet when removing covers, lubricating, or when making any of the user servicing adjustments mentioned in the instruction manual.
15. Keep fingers away from moving parts, especially the area near the blades.
16. Please note that on disposal, this product must be safely recycled in accordance with relevant National legislation relating to electrical / electronic products. If in doubt please contact your retailer for guidance.
17. This appliance can be used by children aged from 8 years and above and persons with reduced physical, sensory or mental capabilities or lack of experience and knowledge if they have been given supervision or instruction concerning use of the appliance in a safe way and understand the hazards involved.
18. Children shall not play with the appliance.
19. Cleaning and user maintenance shall not be made by children without supervision.
20. - Moving Parts- To reduce risk of injury, switch off before servicing.
CLOSE COVER BEFORE OPERATING MACHINE
21. Do not allow the power cable and controller cable to be scarred, damaged, modified, excessively bent, pulled, twisted, or bundled. If heavy objects are placed on the power cable or it is subjected to heat, it may be damaged, possibly causing fire or electrical shock.



European Union only

"SAVE THESE INSTRUCTIONS"

"This overlock machine is intended for household use."

Welcome to the Baby Lock evolve

Your Baby Lock evolve provides chain stitching, cover stitching, and overlocking. The Baby Lock evolve has an exclusive "Thread Delivery System" that eliminates confusing tension adjustments. The evolve enables you to accomplish a perfect stitch with any type of thread on any type of fabric. You no longer need to guess at the correct tension adjustments.

Your Baby Lock evolve is a high-quality, dependable machine. It gives you the ability to seam, overcast and trim all in one operation. Fabrics and threads you previously avoided are now a joy to sew because the Baby Lock evolve handles all varieties with equal ease. With the Baby Lock evolve your creative options are endless and your time spent serging is more fulfilling and rewarding. With the "Instant Jet-Air Threading", even threading the evolve is a breeze.

With proper care and maintenance, your Baby Lock evolve promises years of high-quality, dependable performance and sewing pleasure. Keep this instruction manual as a step-by-step guide to become familiar with your Baby Lock evolve and expand your sewing horizons.

Happy Sewing!



evolve

Table of Contents

OVERVIEW	4
How Your Machine Operates.....	4
Overview of the evolve.....	5
Accessories.....	6
Needles.....	7
Thread.....	7
Optional Accessories.....	7
Setting Up Your evolve.....	8/9
Cutting Blade Lock Switch.....	10
Cutting Blade Cover and Sewing Table.....	10
Upper Looper Positioning Lever.....	10
Thread Cutter.....	11
Presser Foot Pressure Adjustment.....	11
Snap-on Presser Foot.....	11
Stitch Length / Rolled Hem.....	12
Stitch Width.....	12
Differential Feed.....	13
Overlock Thread Delivery System.....	14
Stitch Selector Lever.....	14
Side Cover.....	14
Chain/Cover Stitch Tension Dials.....	15
Needle Tension Dial.....	15
Chain Looper Tension Dial.....	15
2-Thread Subsidiary Looper.....	16
Upper and Lower Looper Thread Fine-Tuning Screw.....	16
Notes.....	17
THREADING	18
Threading Preparation.....	18
Threading Your evolve.....	19
Locked Position for Threading.....	19
Thread Stand and Thread Port Reference Chart.....	19
Lower Looper.....	20
Upper Looper.....	20
Chain Looper.....	21
Chain/Cover Needles.....	22
Left Needle - C-1.....	22
Center Needle - C-2.....	22
Right Needle - C-3.....	22
Overlock Needles.....	23
Left Needle - O-1.....	23
Right Needle - O-2.....	23
How to Use the Needle Threader.....	24
Front Cover Seam Guide.....	24
Start to Sew.....	25
To Chain-Off of the Fabric.....	25
Clearing the Stitch Width Fingers.....	26
Re-threading Loopers.....	26
OVERLOCK STITCHES	27
4-Thread Overedging.....	27
Overlock Seam.....	27
4-Thread Overlock.....	28
3-Thread Overlock - Wide.....	29
3-Thread Overlock - Narrow.....	30
3-Thread Overlock - Narrow Hemming.....	31
Rolled Edging.....	32
3-Thread Rolled Edge.....	32
Seaming Sheers.....	33
Lettuce Edge.....	33
Belt Loops and Button Loops.....	33
Returning to Standard Serging.....	33

Table of Contents (Cont.)

3-Thread Flatlock.....	34
2-Thread Overlock.....	35
Converting from 3-thread to 2-thread overlock.....	35
2-Thread Flatlock - Wide.....	36
2-Thread Flatlock - Narrow.....	37
Blanket Stitch - Decorative Stitch.....	38
Ladder Stitch - Decorative Stitch.....	39
CHAIN/COVER STITCH - Express Stitches.....	40
Chain Stitching.....	40/41
Chain Stitch - Tension Adjustment.....	41
Chain Stitch Right Narrow-3mm.....	42/43
Chain Stitch - Tension Adjustment.....	43
Cover Stitch Left Narrow-3mm.....	44/45
Cover Stitch - Tension Adjustment.....	45
Cover Stitch - Wide - 6mm.....	46/47
Cover Stitch Tension Adjustment.....	47
Triple Cover Stitch-6mm.....	48/49
Chain Stitch - Tension Adjustment.....	49
COMBINATION STITCH - Expressive Stitches.....	50
4-Thread Safety Stitch.....	50/51
5-Thread Safety Stitch.....	52/53
8-Thread Stitch.....	54/55
Expressive Stitches:.....	56/57
Chain/Cover Stitches combined with Overlock Stitches.....	56
Expressive Combinations.....	56/57
TECHNIQUES.....	58
Turning Corners - Chain Stitch.....	58
Turning Corners - Cover Stitch.....	58
Turning Outside Corners - Overlock.....	59
Turning Inside Corners - Overlock.....	59
Flat Hemming - Cover Stitch.....	60
Hemming in the Round - Cover Stitch.....	60
Blind Hemming - Overlock.....	61
Sewing Curves - Overlock.....	61
Inserting Tapes - Overlock.....	62
Inserting Tapes - Cover Stitch.....	62
Flatlock "Decorative" - Overlock.....	63
Securing Ends - Overlock.....	64/65
Securing Chain and Cover Stitching.....	66
Notes.....	67
SPECIALTY THREADS.....	68
Using Specialty Threads.....	68
Lightweight Threads.....	68
Mediumweight Threads.....	68
Heavyweight Threads.....	68
Bypassing the Threading Port.....	69
Looper Threading Tool.....	70
Thread Cradle for Loopers.....	71
Specialty Thread Guide Chart.....	72/73
MAINTENANCE.....	74
Troubleshooting.....	74/75
Replacing Needles.....	76
Replacing Cutting Blades.....	77
Replacing Light Bulb.....	77
Cleaning.....	78
TECHNICAL DATA.....	79
Technical data.....	69
STITCH SELECTION CHART.....	80
Chart for Stitch Selection Setting for Chain/Cover and Combination Stitches	80/81

How Your Machine Operates

Sometimes called an overlock machine or overlocker, the serger is different from any conventional sewing machine you have used. Awareness of its simple operation will enable you to become more proficient in its use. Please read all instructions before using your new machine.

A serger is kind of a knitting process that loops two, three or four threads together to create a stitch.

Your Baby Lock evolve operates with one or two needles in the overlock position and one or two loopers to form an overlock stitch. Use one or two chain/cover stitch needles and one looper for a chain or cover stitch. Uniquely independent of each other, you can use any of the overlock or chain/cover stitch selections separately or in combination.

When fabric is placed in front of the presser foot, it reaches the feed dogs first. The feed dogs move the fabric along as the cutting blades trim the fabric edge, creating a clean edge to be finished. Or disengage your blade and insert the sewing table to sew a chain stitch in the center of your fabric.

The overlock stitch is supported by one or more parallel "stitch finger(s)" that keep the fabric flat. To form an overlock stitch, the threads become "locked" "over" the edge of the fabric encasing the raw edge with thread to prevent fabric raveling. When forming a chain stitch, the chain needle thread catches the chain looper to form a straight stitch on the top of your fabric and thread chain loops on the underside. Use 2 cover stitch needles and the chain looper to form a double row of straight stitching on the top and a weave of thread on the underside of your fabric.

After setting up your machine for the first time, take a few moments to learn how it sews. Before your machine is threaded, turn the handwheel toward you and watch the operation of the various parts.

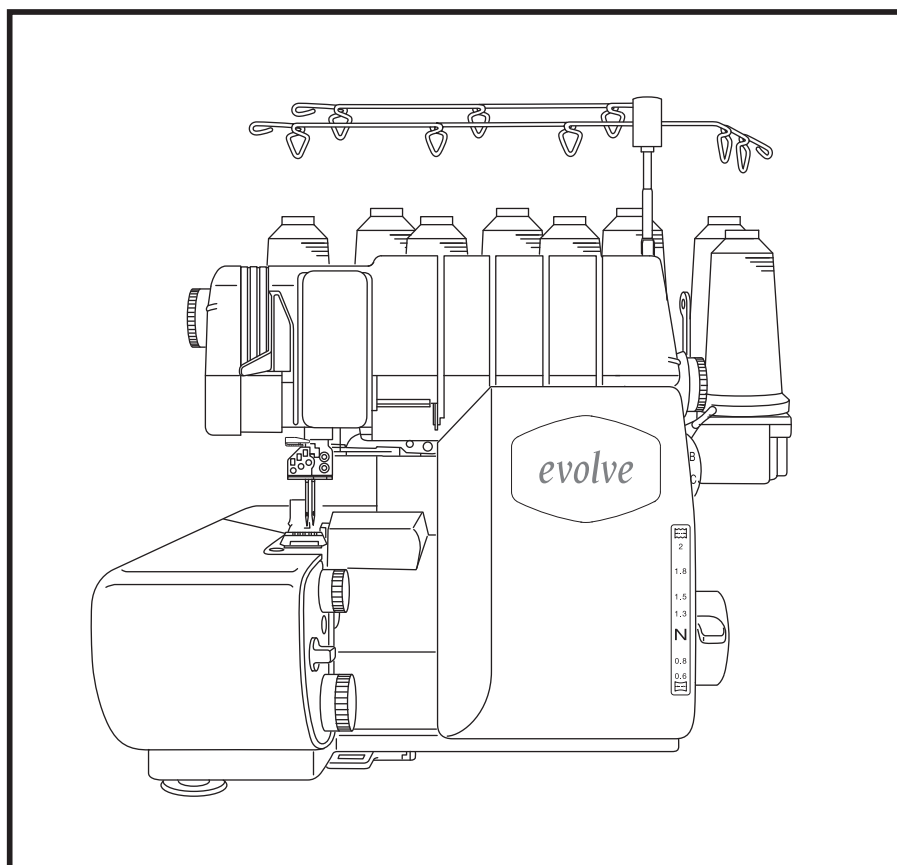

Overview of the evolve

1. Upper looper positioning lever
2. Presser foot adjusting screw
3. Presser foot thread release lever*
4. Thread cutter
5. Chain/cover stitch needle tension dial
6. Needle height viewing area
7. Needle clamp screws
8. Snap-on presser foot
9. Needle plate
10. Stitch width adjusting dial
11. Side cover
12. Cutting blade lock switch
13. Stitch length/rolled hem adjusting dial
14. Cutting blade cover
15. Needle drop drawer
16. Subsidiary looper
17. Front cover
18. Machine lock button release lever
19. Machine lock button
20. Looper threading lever
21. Chain looper threading port
22. Differential feed adjusting lever
23. Handwheel
24. Lower looper threading port
25. Power switch
26. Looper threader selector
27. Overlock stitch selector
28. Accessory compartment & spool stand
29. Upper looper threading port
30. Chain/cover stitch looper tension dial
31. Carrying handle
32. Upper & Lower looper thread fine-tuning screw
33. Telescopic thread guide and antenna

* Raising the presser foot releases all threads.

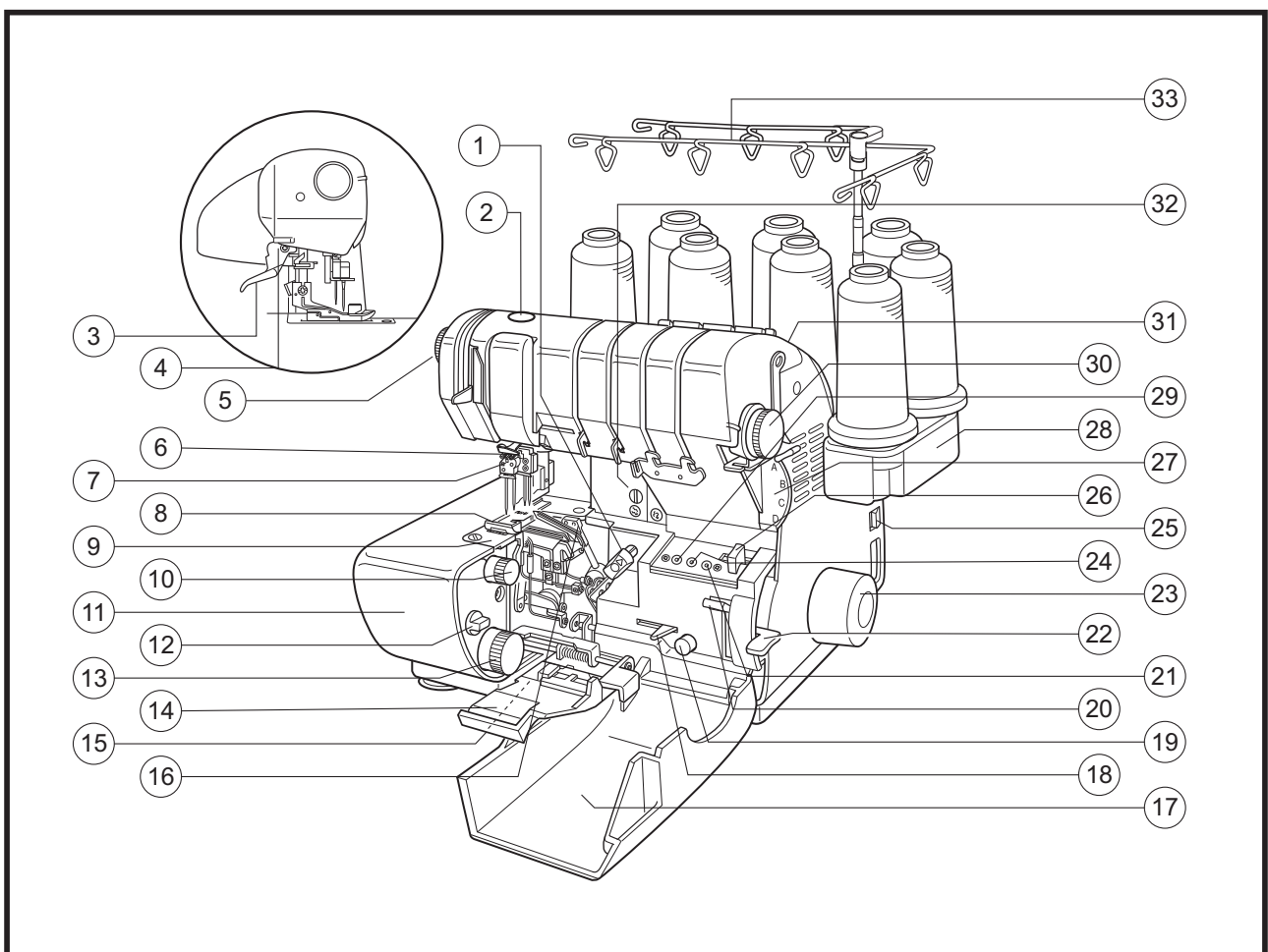

Accessories

Your Baby Lock evolve serger has a built-in accessory compartment. To open, swing the "lid" on the thread spoolstand to the right to reveal the tray holding some of the accessories listed below. Others may be found in the machine packing materials.

Accessory	Number included	Located in
Instruction manual	1	Packing box
Quick reference threading guide	1	Packing box
Flat table for chain/cover stitching	1	Packing box
Guide fixing screws for table	2	In flat table
Lint brush/needle insert tool	1	Accessory compartment
Package of assorted sized needles Organ ELx705CF	1	Accessory compartment
Allen screwdriver	1	Accessory compartment
Tweezers	1	Accessory compartment
Upper cutting blade for replacement	1	Accessory compartment
Needle threader	1	Accessory compartment
Overlock needle screws	2	Accessory compartment
Chain/Cover stitch needle screws	2	Accessory compartment
Looper threading tool	1	Accessory packet
Screwdriver	1	Accessory packet
Machine cover	1	Accessory packet
Thread nets	8	Accessory packet
Spool caps	8	Accessory packet
Sponge disks	8	Accessory packet
Cone holders	8	On machin

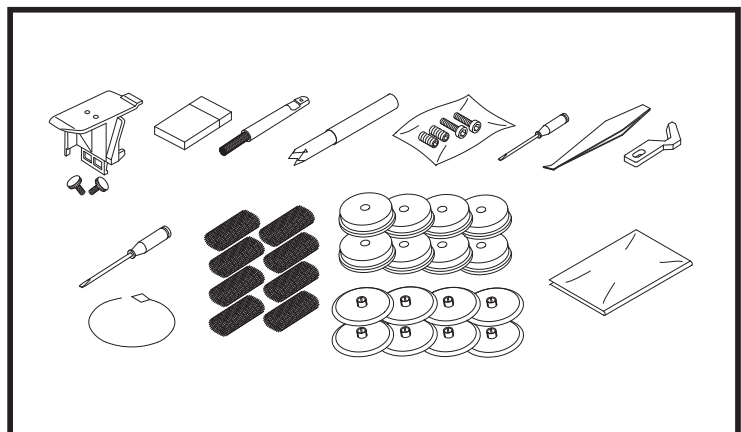
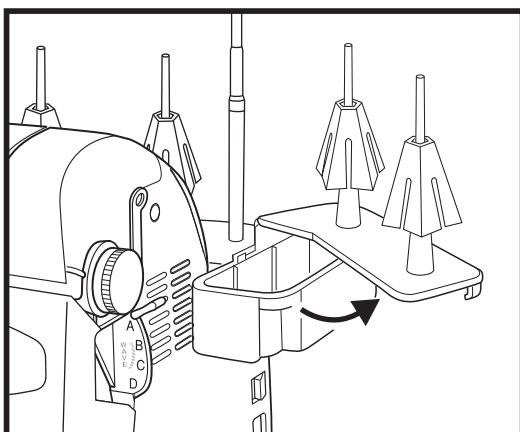

Needles

Your Baby Lock evolve serger is set up with Organ ELx705CF needles size 90/12. This is suitable for most medium and heavyweight fabrics. For lightweight fabrics use size 80/12, ELx705CF needles. The ELx705CF needle is a semi-ballpoint design and is suitable for knits and wovens.

Thread

All types of thread may be used on your Baby Lock, but 100% long-staple polyester thread, crosswound on a cone, consistently provides the best stitch performance. Because the threads must pass through several thread guides at high speeds, they must be of uniform thickness and high strength with a minimum amount of linting.

Good-quality cotton or cotton-covered polyester threads sew well, though they produce more lint, creating the need to clean the machine more frequently. They work well for overedging and seaming, but they may be too weak or too fuzzy for the rolled edge. Poor grades of thread can result in frequent fraying, breaking and unbalanced stitches.

Threads of other fiber contents and weights may be used, depending on their strength and thickness. Testing will help you determine how easily they can pass through the thread guides, thread slots, needles and loopers.

Important Note: For maximum performance of the Baby Lock evolve, it is recommended to use "100% polyester-long fiber thread". Recommended brands are Maxi-Lock and Metrosene. This thread also performs best when used with many decorative threads for sewing specialty decorative techniques.

Optional Accessories

OVERLOCK OPTIONAL ACCESSORIES

Beading Foot	B5002-04A-C
Blindhem Foot	B5002S06A
Elastic Applicator Foot	B5002S09A
Lace Applicator Foot	B5002S08A
Piping Foot/5mm Cording	B5002-05A-C
Ruffling Foot	B5002S07A

CHAIN/COVER STITCH OPTIONAL ACCESSORIES

Belt Loop Folder 3/4"	B0421S12A
Belt Loop Folder 1-1/2"	B0421S11A
Double Fold Bias Binder 28mm	B0421S03A
Double Fold Bias Binder 36mm	B0421S02A
Fabric Guide	B0420S01A
Pintuck Foot w/2 Guides	B5002-06A-C
Plain Hemmer 1/4"	B0421S07A
Plain Hemmer 1/2"	B0421S06A
Single Downturn Feller 1/4"	B0421S10A
Single Downturn Feller 5/8"	B0421S08A
Single Downturn Feller 1"	B0421S09A
Single Fold Bias Binder 28mm	B0421S04A
Single Fold Bias Binder 40mm	B0421S05A

OTHER OPTIONAL ACCESSORIES

Bulb Remover tool	B7525-01A
-------------------	-----------

Setting Up Your evolve

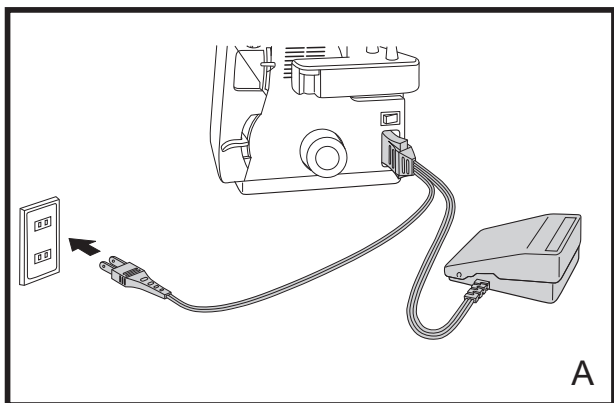

A

1. Remove machine from box

After removing the packing materials from the box, gently lift your Baby Lock serger by grasping the handle provided on the top of the machine. Place the machine on a serger sewing table or any level surface that provides ample work area to the left. Place the foot controller in a pedal stay, if desired, and place it under the sewing table.

2. Plug in the machine

Plug the power cord into the machine first, then into a wall outlet. The power switch is located toward the back on the right side of the machine. Always make sure the power is off when the machine is not in use (fig. A). Available foot controller for 220-240V area: model 483N-1.

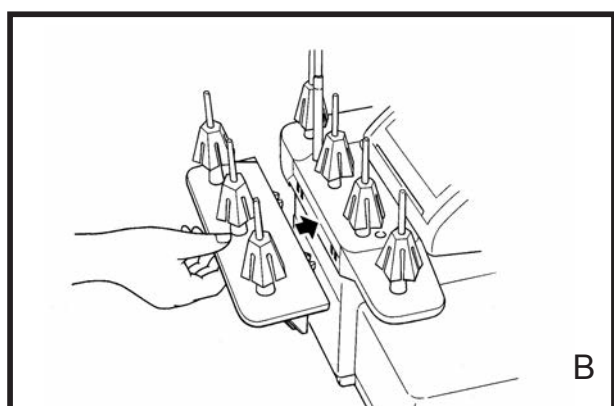

B

3. Foot controller

The sewing speed of the machine is determined by the amount of pressure applied to the foot controller. When not in use, do not place anything on the foot controller, or the machine could start inadvertently and the controller or motor could burn out.

4. Spool pin extension table

To insert the spool pin extension:

Place the pegs into the slots on the back of the main thread spool stand.

Push the extension thread stand onto the main thread spool stand until it snaps into place (fig. B).

To remove:

Hold the back of the extension table with both hands. Raise it up and out to release from the main thread spool stand (fig. C).

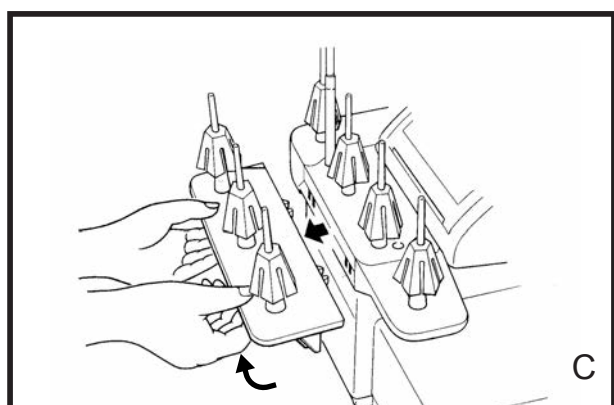

C

Setting Up Your evolve

5. Position the telescopic thread guide.

Raise the telescopic thread guide to its highest position. Rotate the shaft to the left and right until each section "clicks" into a locked position (fig. D).

6. Thread guide extension

To install: Snap & lower. Place plastic support of thread guide extension on top of main telescopic thread guide. Support the main guide with one hand and snap the extension guide to the back with your other hand (fig. D). Lower into position. To remove: Raise & pivot. Raise the plastic support straight up and pivot the back of the support up to release (fig. E).

7. Opening front cover

The front cover may be opened simply by placing your fingers behind the tab at the right side and pulling toward you (fig. F).

8. Opening Cutting blade cover

To open the cutting blade cover, place your thumb against the tab, and slide the cover to the right. A slight pull toward you will allow the cover to swing down, providing access to the loopers, blades, and thread guides (fig. G).

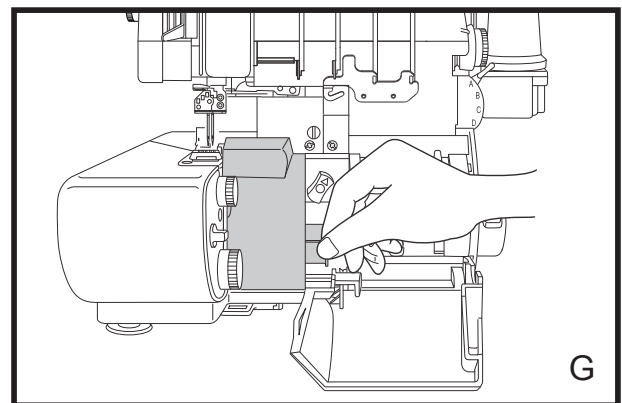
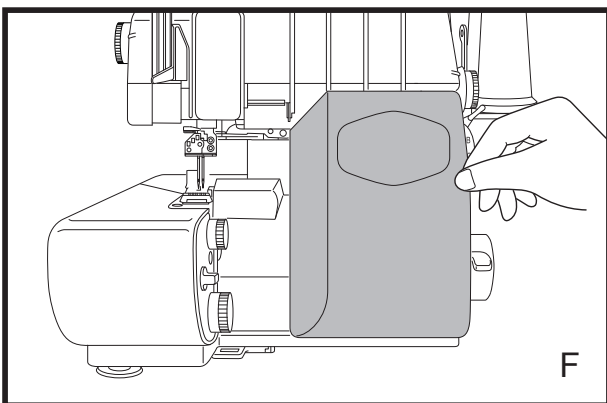
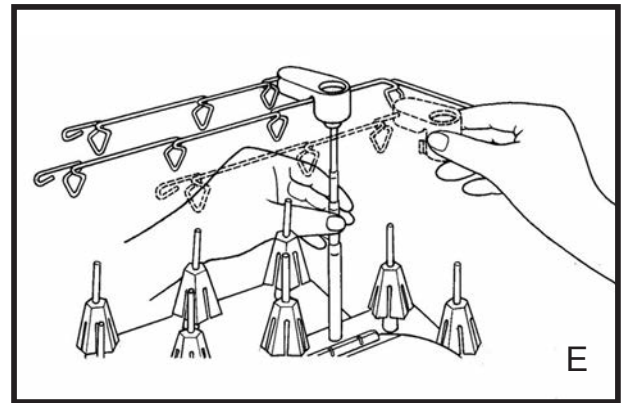
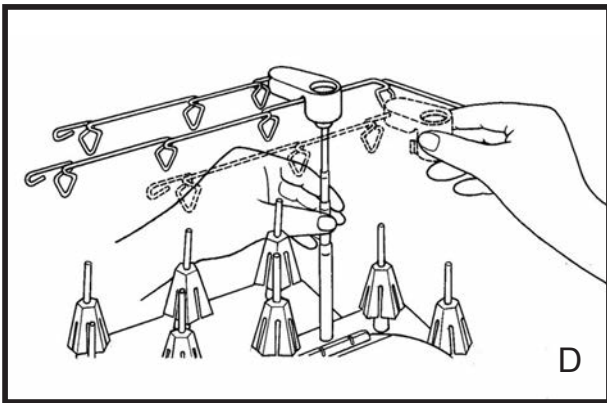

Your machine is pre-set to sew an overlock with a chain stitch. The upper blade is engaged to cut the fabric while sewing. Of course, you may select to engage or disengage the cutting blade. You can change the blade cover to the sewing table and lock the upper looper down when sewing only the chain stitch.

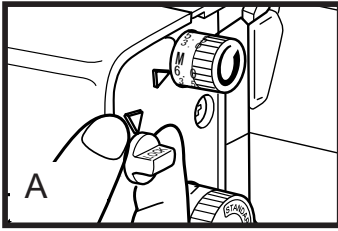

Cutting Blade Lock Switch

To lock cutting blade down:

Turn the dial clockwise 180 degrees to see "LOCK" on the top. The cutting blade will stay below the needle plate for non-cutting techniques (Fig. A).

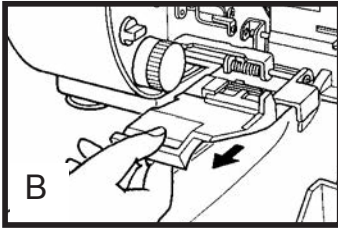

To re-engage cutting blade:

Turn the cutting blade lock switch half of a turn counter-clockwise. The blade will start moving automatically when you start sewing.

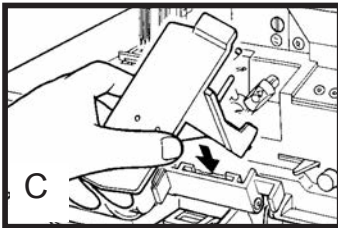

Cutting Blade Cover and Sewing Table

Cutting blade cover can be changed to sewing table for chain/cover stitching.

- Open front cover and cutting blade cover (See page 9, C & D).
- Gently pull toward you to unsnap cover (Fig. B) and snap sewing table into place (Fig. C).
- Lower the upper looper positioning lever.
- Close the sewing table door and then the front cover (Fig. E).

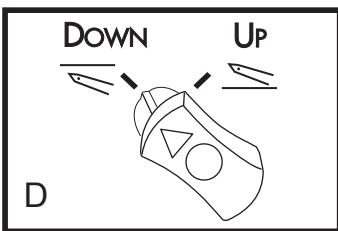

Upper Looper Positioning Lever

When you change from overlocking to chain/cover stitching, you should also change the upper looper positioning lever to the "DOWN" position before you close the sewing table door.

- Turn the handwheel until upper looper is at its lowest position.
- Change the upper looper positioning lever to the "DOWN" position (Fig. D).
- Close the sewing table door and then the front cover (Fig. E).

Note: Make sure the upper looper positioning lever is in the "UP" position prior to locking the machine to thread the upper looper.

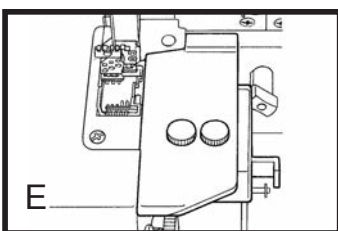

Thread Cutter

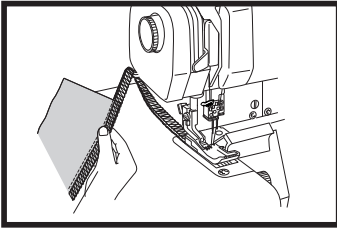

There is a thread cutter located on the left side of your evolve. At the end of a seam, sew off the fabric edge and continue sewing to create a 5-6 inch (12,5-15cm) thread chain. Bring the chain of thread up and from the back to front through the thread cutter.

Presser Foot Pressure Adjustment

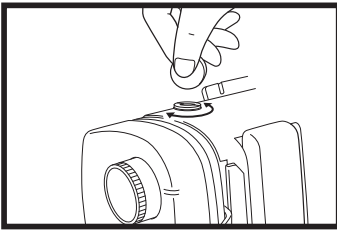

The presser foot pressure has been preset at the factory and rarely needs adjustment. You may find it necessary, however, to decrease the pressure for thick fabrics or increase pressure for thin fabrics to feed more smoothly under the foot. Use a coin to turn the screw on top of the machine. To increase pressure, turn the pressure adjusting screw clockwise. To decrease pressure, turn the screw counterclockwise.

Snap-On Presser Foot

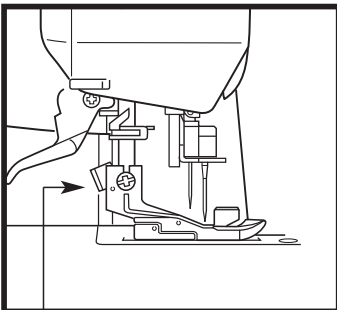

Presser Foot
Release Lever

The evolve has the convenience of a snap-on presser foot.

To Release:

1. Raise the presser foot lever.
2. Lower the cutting blade.
3. Raise the needles to the highest position.
4. Push the presser foot release lever located at the back of the presser foot holder.
5. Carefully turn the presser foot clockwise 90 degrees.
6. Slide the presser foot to the rear to remove.

To Replace:

1. Raise the presser foot lever.
2. Lower the cutting blade.
3. Raise the needles to the highest position.
4. Slide the foot from the left to right.
5. Align the bar of the foot with the groove in the holder.
6. Lower the presser foot lever to snap into place.

The presser foot that comes with the evolve has a tape sewing slot. Insert the tape or ribbon, into the slot in the front of the foot, then under the sole of the foot. (see page 62 for more instruction)

The raised markings on the toe of the foot are seam line guides. They indicate the needle positions to help guide your fabric for accurate seaming.

Stitch Length/Rolled Hem

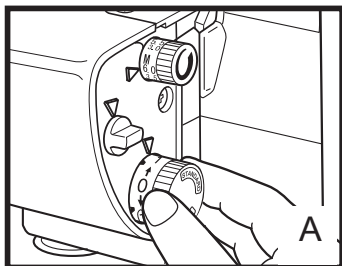

The stitch length / rolled hem adjusting dial is conveniently located just to the left of the front cover, near the base plate (fig. A). The dial shows two stitch-length ranges, from 0,75, for the shortest stitch, to 4 for the longest. As the dial indicates, one range is for standard sewing and one is for rolled edging or narrow seaming.

Simply turn the dial aligning the desired setting with the indicator mark on the machine. A stitch length of 3mm, or about 10 stitches per inch is ideal for seaming and overedging most fabrics. For overedging or seaming very lightweight fabrics, you may prefer a shorter stitch length. When sewing heavier fabrics, you may choose to lengthen the stitch (fig. B).

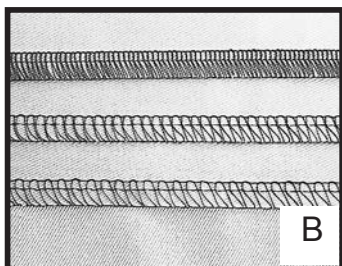

Note: 0,75mm is located between the 0 and 1 on both standard & rolled settings.

Stitch Width

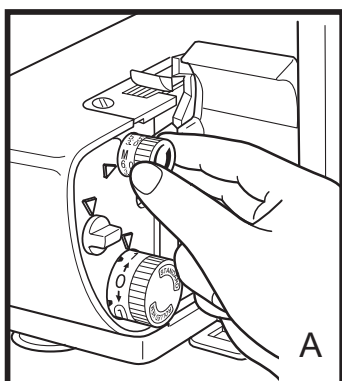

The stitch width adjusting dial is located above the stitch length dial (fig. A). The stitch width displays two sets of numbers, indicating two width ranges. for overlock stitches. The larger size numbers on the dial, 5,5 through 7,5mm, denote the stitch width when the 0-1 (left hand) needle is in use. The smaller size numbers, 3,0 through 5,0mm, apply when only the 0-2 (right-hand) needle is in use for forming a 3-thread stitch. The "M" setting (3,5) is for the rolled edge.

Adjusting the stitch width moves the upper cutting blade. It also moves the stitch fingers further apart or closer together for complete fabric support with any stitch width.

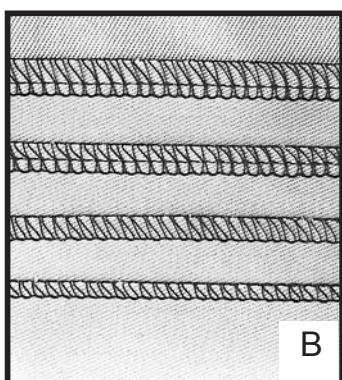

The stitch width is infinitely variable between either end of the range. Simply turn the dial aligning the desired setting with the indicator mark on the machine. Use a wider stitch on loosely woven fabrics. You may prefer a narrower stitch width on knits, tightly woven, or sheer fabrics (fig. B).

Differential Feed

Your Baby Lock serger is equipped with differential feed. The set of feed dogs work independently in order to ensure smooth sewing on all fabrics (fig. A).

When the differential feed adjusting lever, located at the machine's right, front edge is set on "N" for normal feeding, the feed dogs move the same distance. This is the setting to use for most fabrics and applications (fig. B).

When the dial is set above "N", the front feed dog will feed more fabric than the back. This is because the front feed dog moves at a greater distance than the back feed dogs. As a result, the fabric becomes compressed or eased, as the diagram on the front cover indicates. This can eliminate wavy seams in stretchy fabrics or those cut on the bias grain.

At the maximum setting of 2,0 (fig. C), the differential feed can gather a lightweight fabric to nearly double fullness (fig. D). The front feed dog is actually feeding in twice as much fabric as the back feed dog is feeding out. To maximize the gathering effects, use the longest stitch length setting. Fabric weight will affect the gathering. Test stitch for desired results.

When the differential feed lever is set below "N" (fig. F), the front feed dog moves less distance than the back feed dog. This adjustment stretches the fabric slightly as it is sewn. The lower settings prevent puckers on lightweight fabric (fig. E), add more stretch to swim wear, active wear, and can be used to create a lettuce edge (see page 33).

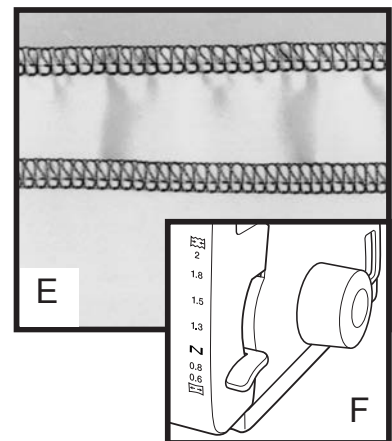
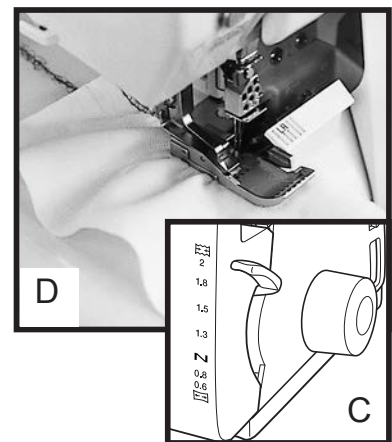
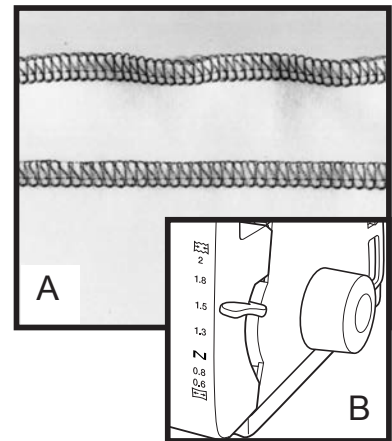

Overlock Thread Delivery System

The Baby Lock evolve revolutionizes the way a serger works with its exclusive overlock Thread Delivery System. You no longer have to manually adjust the tension settings for the type of overlock stitch you are sewing. Select the type of overlock stitch you wish to serge, the evolve will automatically feed the correct amount of thread through the needles, the loopers and thread guides to form a perfect stitch every time.

Stitch Selector Lever

The stitch selector lever which controls the overlock thread delivery system for overlock stitching is located on the right side of the machine. Select appropriate setting, A, B, C, or D.

- A - for overlock stitches using the left needle (O-1) and the looper threads balanced.
- B - for overlock stitches using the right needle (O-2) and the looper threads balanced.
- C - for narrow stitches with a short length and the looper threads balanced.
- D - for stitches that require a tight lower looper.

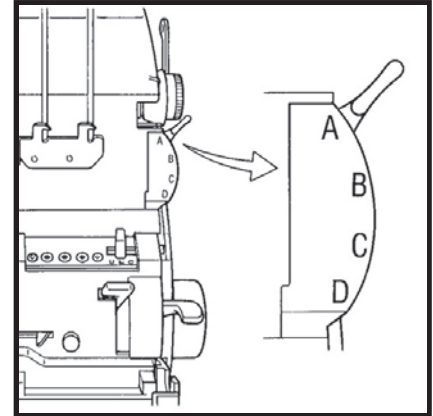

See chart on last page for stitch selection settings.

Side Cover

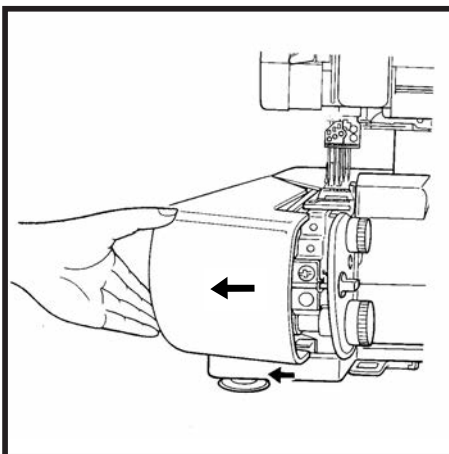

Open side door on the left for easy access to the chain looper thread tray.
Close door before sewing.

Chain/Cover Stitch Tension Dials

The tension system of the chain and cover stitches are completely separate from the system being used on the overlock stitches. Unlike the thread delivery system of the overlock stitches, the tensions of the chain / cover stitch needles and chain looper are adjusted by dials located on the outer sides of your evolve.

Needle Tension Dial

The needle tension dial is located on the top left side of the machine. One tension dial controls all 3 of the chain/cover stitch needle selections. Normally set at "5", the dial can be turned from 0 - 9 to increase or decrease the tension on the chain/cover stitch needle threads.

Increase the tension by turning the dial to a larger number.

Decrease the tension by turning the dial to a smaller number.

Align the number with the indicator mark on the front of the machine near the dial.

Chain Looper Tension Dial

The chain looper tension dial is divided into 2 sections - Chain Stitch and Cover Stitch. The dial is located on the top right side of the machine. Align the selected tension setting with the indicator mark on the front right of the machine.

The Chain Stitch section of the looper tension dial has a tighter looper tension for sewing chain stitch. Select the row of stripes on the dial for chain stitching. The wider the stripe the tighter the chain looper tension.

The Cover Stitch section of the looper tension dial has a looser tension for sewing wide, narrow or triple

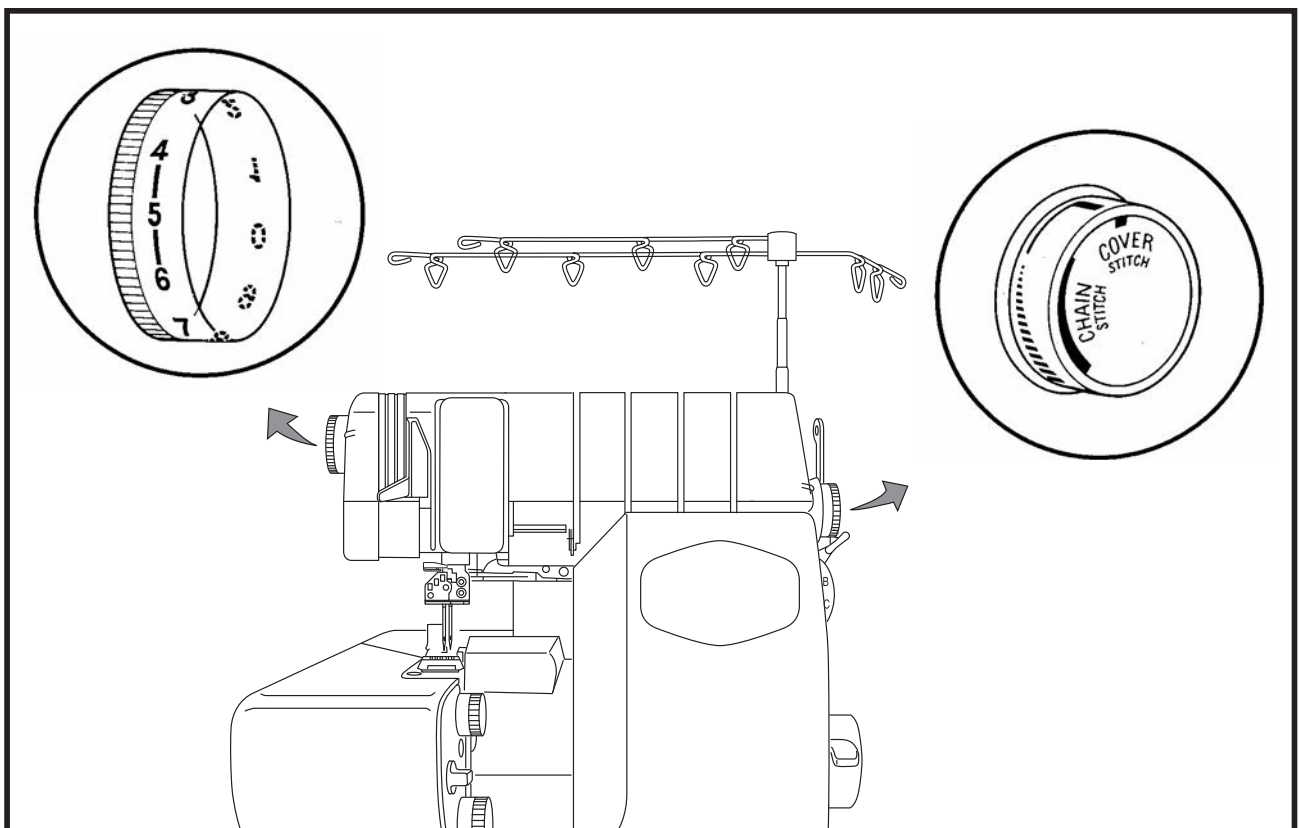

2-Thread Subsidiary Looper

Either needle thread may be engaged for 2-thread overlock sewing

1. Open the front cover and the blade cover, cut the upper looper thread just above the threading port (fig. A). Raise the presser foot and pull out the clipped thread from under the foot.
Remove the upper looper thread from the machine.
2. Rotate the handwheel to bring the upper looper to its lowest position.
3. Rotate the subsidiary looper up and to the left (fig. B), insert the end into the upper looper eye (fig. C).
4. Close the blade cover and the front cover.

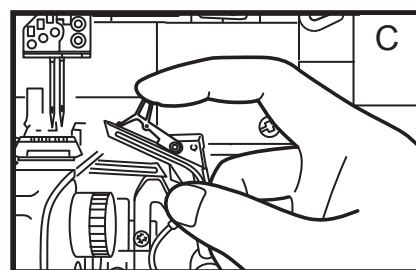
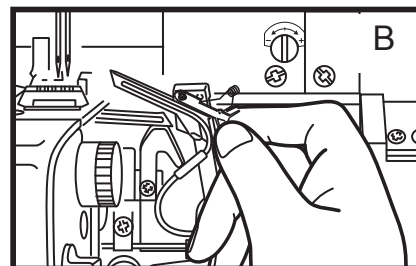
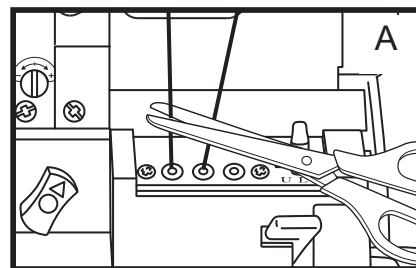

Upper and Lower Looper Thread Fine-Tuning Screw

No adjustments are needed when sewing with most fabrics and threads on your Baby Lock evolve, but certain threads or fabrics may require minor fine-tuning of the looper delivery system to perfect your stitches. Increase or decrease the delivery of the looper threads with the upper and lower looper thread fine-tuning screw. With a screwdriver (found in accessory kit), turn the fine-tuning screw clockwise to tighten the looper threads. Turn the screw counter-clockwise to loosen the looper threads.

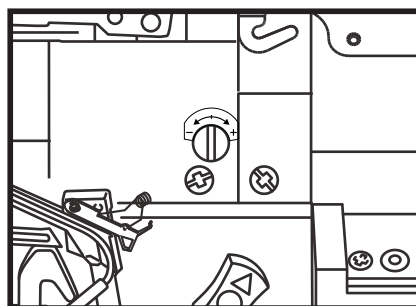

Ideal Stitch



Standard Position

Upper and lower looper threads are too loose.

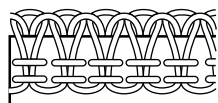

Tighten the screw (+)

Upper and lower looper threads are too tight.

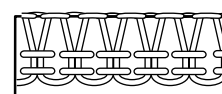

loosen the screw (-)

Threading Preparation

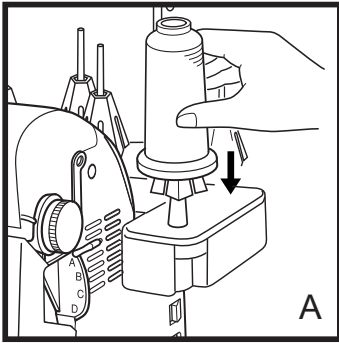

Large spools with Cone Holders.

When using threads on cones or king spools place the cone or spool securely over the cone holders furnished on your machine. To avoid bending the thread stand, you may need to place one hand under the stand while positioning the cone. The cone holders prevent the cone or spool from spinning, enabling the thread to feed evenly (fig.A).

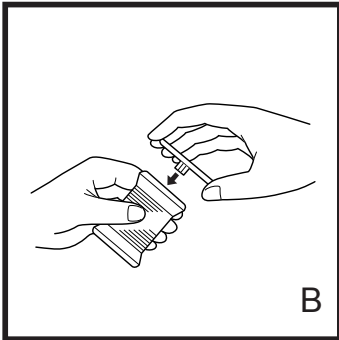

Standard sewing thread with spool cap.

Because threads for the serger feed from the top, standard spool threads can snag on the rough edges of many of these spools. That's why spool caps are furnished with your serger to provide a smooth surface that enables the thread to reel off freely. With the spool notch side down, insert a spool cap into the top of the spool (fig.B).

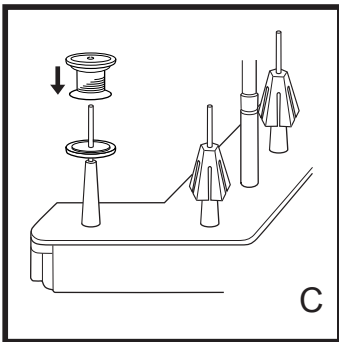

Standard sewing thread with sponge disk and spool cap.

When using standard spool threads on your serger, replace the cone holders with the sponge disks furnished with your machine. These disks hold smaller spools securely and help the thread to reel off properly. With the sponge disk in place, put the capped spool on the spindle (fig.C).

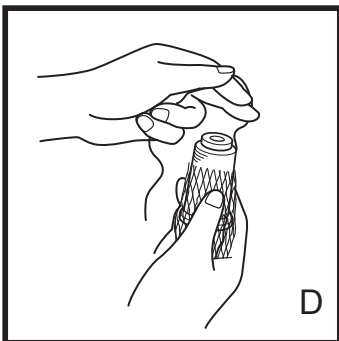

Thread net on thread.

Thread nets may be placed over threads that tend to slip off the bottom of the spool during sewing. Most threads do not require their use, but nets often are necessary with nylon, rayon or silk threads (fig.D). Once it's on the spool, fold the net back on itself. Pull thread from the top of spool to enable the thread to feed evenly (fig.E).

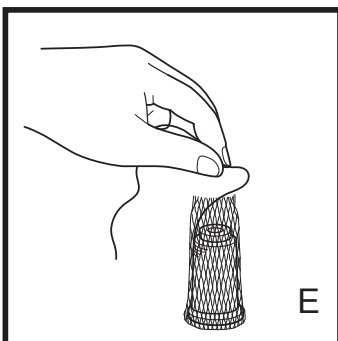

Pulling thread through thread net.

Threading Your evolve

Your Baby Lock evolve is equipped with an exclusive "Instant Jet-Air Threading System" for fast, easy threading of the upper, lower, and chain loopers.

One push of the "Jet-Air" threading lever will automatically thread the loopers. It is no longer necessary to use tweezers for threading the thread guides. If a looper thread breaks or runs out, just re-thread it. There is no need to follow threading sequence.

Locked Position for Threading, Thread Stand and Thread Port Reference Chart

1. Open the front cover.
2. Raise the presser foot to release all threads.
3. Set the upper looper positioning lever in the "UP" position.
4. Depress the machine lock button firmly. Rotate the machine handwheel slowly toward you until the button "snaps" into the locked position and the lock button release lever moves to the far left (fig.A).

Note: The evolve must be in the locked position when threading the loopers unless otherwise indicated.

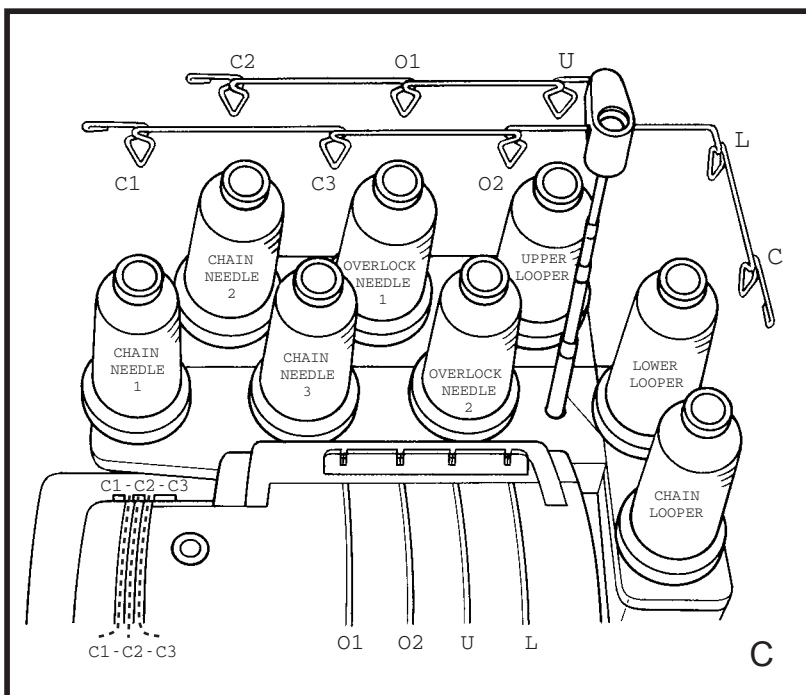
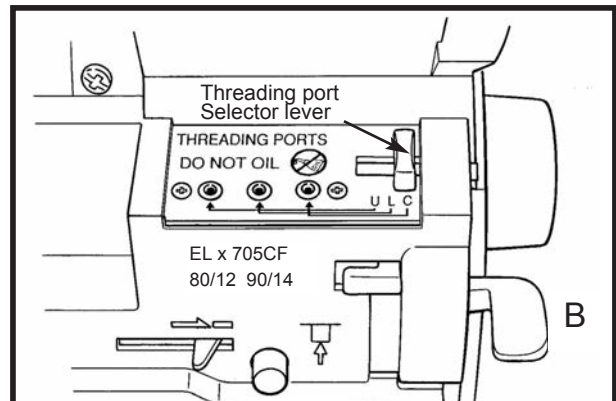
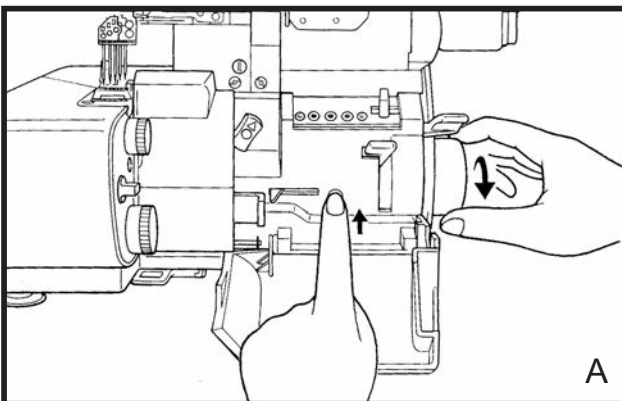

The spool pins and threading ports are color coded for your convenience.

All gold color labels relate to threading for chain and cover stitches.

All green color labels relate to threading for overlock stitches.

Lower Looper

1. With the presser foot up and threading lever in the threading position (fig. A page 19).
2. Place the thread cone or spool on the "LOWER LOOPER" spool pin on the thread stand. Slip the thread into the telescopic antenna thread guide "L" directly above the spool (fig.C,page 19). Snap the thread into the thread guide "L" at the top of the machine and through the slot above the front cover (fig. A).
3. Pull 18 inches (40cm) of thread through guide. Insert the end of the thread into the threading port "L" about 1 inch (2,5cm). Use the tweezers, if necessary, to insert the thread end more easily (fig. E, page 21).
4. Push the threading button (fig. E page 21). If the thread does not go through the lower looper eye with one push, push the threading button again until it does.
5. Clip the thread 4 inches (10cm) from the lower looper eye and leave it hanging loose.
6. Set the threading lever to serging position.

Upper Looper

1. Set the upper looper positioning lever at "UP" position. See picture below for reference.
2. With the presser foot up and threading lever in the threading position (fig. A, page 19).
3. Place the thread on the "UPPER LOOPER" spool pin on the thread stand. Slip the thread into the telescopic antenna thread guide "U" directly above the spool (fig. C, Page 19). Snap the thread into the thread guide "U" at the top of the machine and through the slot above the front cover (fig. A).
4. Pull 18 inches (40cm) of thread through guide. Insert the end of the thread into the threading port "U", about 1 inch (2,5cm). Use tweezers, if necessary, to insert the thread end more easily (fig. E, page 21).
5. Push the threading button (fig. E page 21). If the thread does not go through the upper looper eye with one push, push the threading button again until it does, and leave thread hanging loose.
6. Set the threading lever to serging position.

Note: Make sure that the upper looper positioning lever is always set in the "UP" position whenever you sew overlock or combination stitches (fig B).

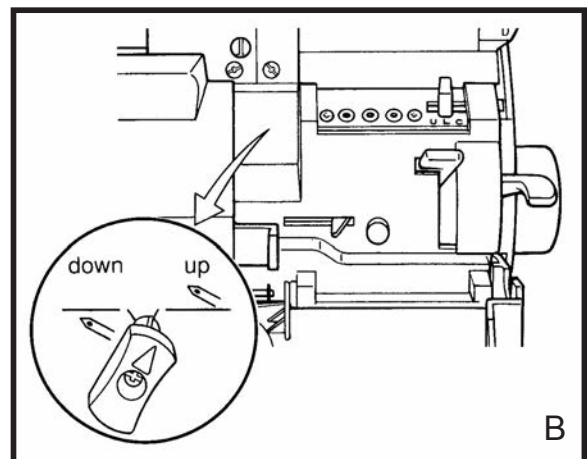
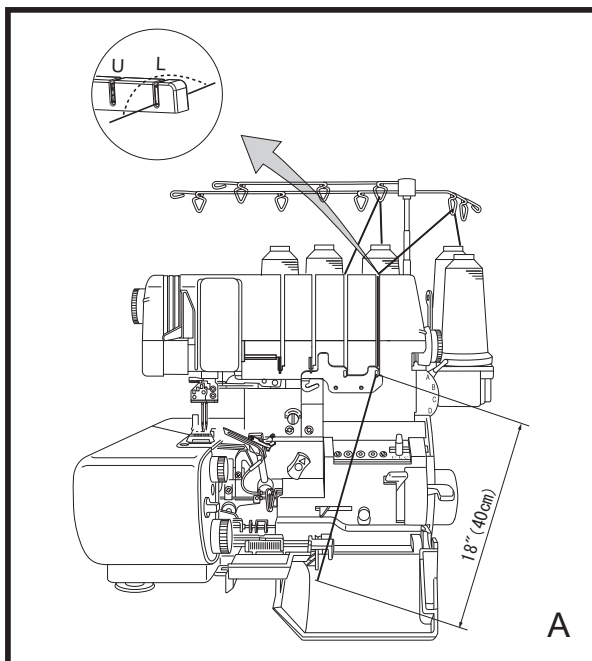

Chain Looper

1. With the presser foot up and machine lock button in the locked position, see fig. A page 19, set the threading port selector lever to "C" for chain looper threading. See fig. B, page 19.
2. Set the stitch selector lever to "D" position for easy threading of the chain looper tension dial.
3. Place the thread cone or spool on the "Chain Looper" spool pin. Slip the thread into the telescopic antenna thread guide extension C directly above the spool. See fig. C, page 19.
4. Insert the thread through the guide above the chain looper tension dial from right to left. Bring the thread to the back and under the thread guide, then up and over the tension dial. See fig. D.
5. Put thread into guide on front of dial, then down to the chain looper threading port.
6. Pull 18 inches (40cm) of thread and insert 1 inch (2,5cm) of thread into the chain looper threading port. Use tweezers if necessary, to insert the thread end. See fig. E.
7. Depress the looper threading lever. See fig. E. If the thread does not go through the chain looper eye with one push, depress the threading lever again until it does.
8. Open side cover to the left for easy access to the chain looper thread in tray. See fig. F.
9. Trim excess thread to 4 inches (10cm) from the eye of chain looper and leave it hang.
10. Close side cover.
11. Move the lock button release lever to the right.

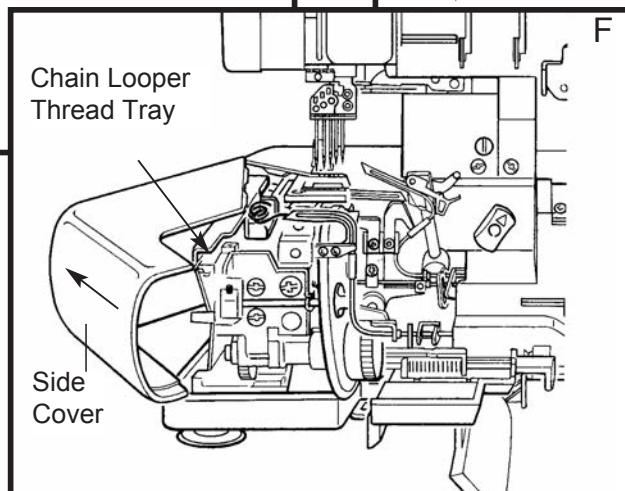
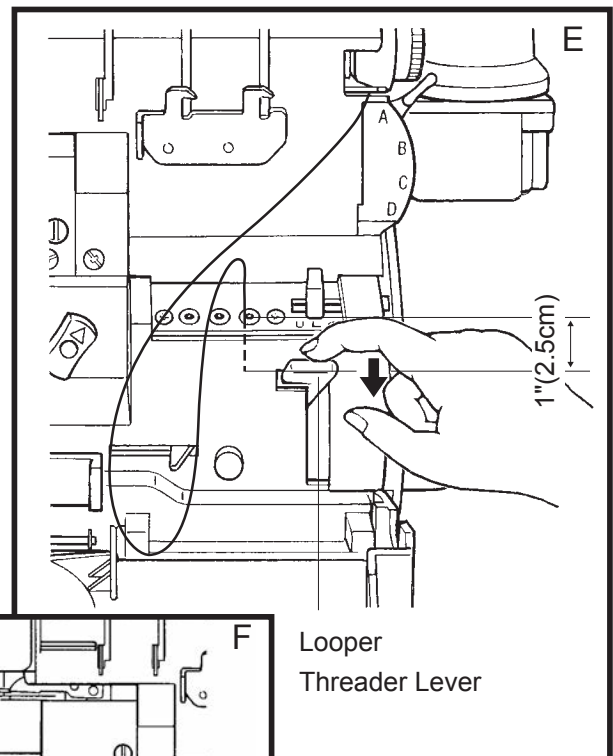
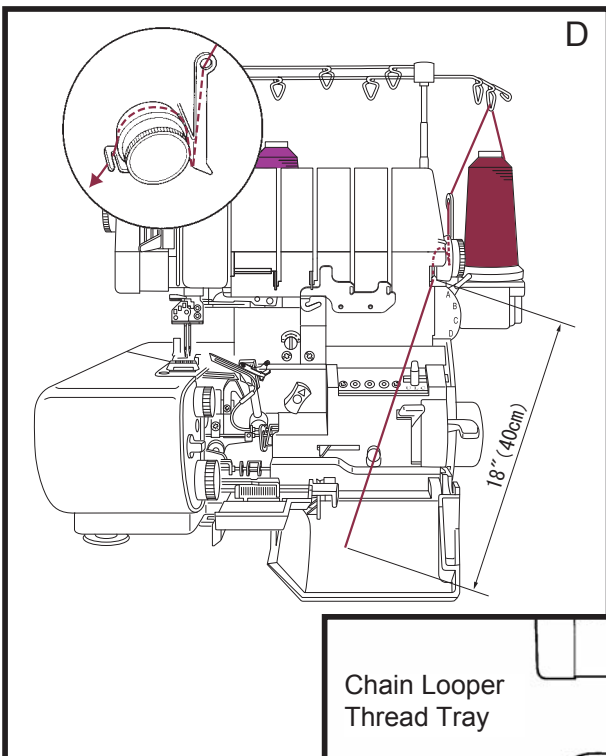

Chain / Cover Needles

Left Chain/Cover Needle C-1

1. Raise presser foot, place the thread on the "Chain Needle 1" spool pin. Slip the thread into the telescopic antenna thread guide "C1" directly above the spool. See drawings below for reference.
2. Bring thread down from the telescopic antenna thread guide into the far left chain/cover needle thread guide "C1". Then insert thread into "C1" slot until thread clicks in. This seats the thread into the tension. Bring the thread behind the front thread guide, up, over and down the right side of the thread take up lever.
3. Insert "C1" thread into pre-tension thread guide on needle clamp and into thread guide above the needle. See drawings below for reference.
4. With the needle threader or tweezers in the accessory compartment, thread needle in "C1" position.

Center Chain/Cover Needle C-2

1. Raise presser foot, place the thread on the "Chain Needle 2" spool pin. Slip the thread into the telescopic antenna thread guide "C2" directly above the spool. See drawings below for reference.
2. Bring thread down from the telescopic antenna thread guide into the center chain/cover needle thread guide "C2". Then insert thread into "C2" slot until thread clicks in. This seats the thread into the tension. Bring the thread behind the front thread guide, up, over and down the right side of the thread take up lever.
3. Insert "C2" thread into pre-tension thread guide on needle clamp and into thread guide above the needle. See drawings below for reference.
4. With the needle threader or tweezers in the accessory compartment, thread needle in "C2" position.

Right Chain/Cover Needle C-3

1. Raise presser foot, place the thread on the "Chain Needle 3" spool pin. Slip the thread into the telescopic antenna thread guide "C3" directly above the spool. See drawings below for reference.
2. Bring thread down from the telescopic antenna thread guide into the far right chain/cover needle thread guide "C3". Then insert thread into "C3" slot until thread clicks in. This seats the thread into the tension. Bring the thread behind the front thread guide, up, over and down the right side of the thread take up lever.
3. Insert "C3" thread into pre-tension thread guide on needle clamp and into thread guide above the needle. See drawings below for reference.
4. With the needle threader or tweezers in the accessory compartment, thread needle in "C3" position.

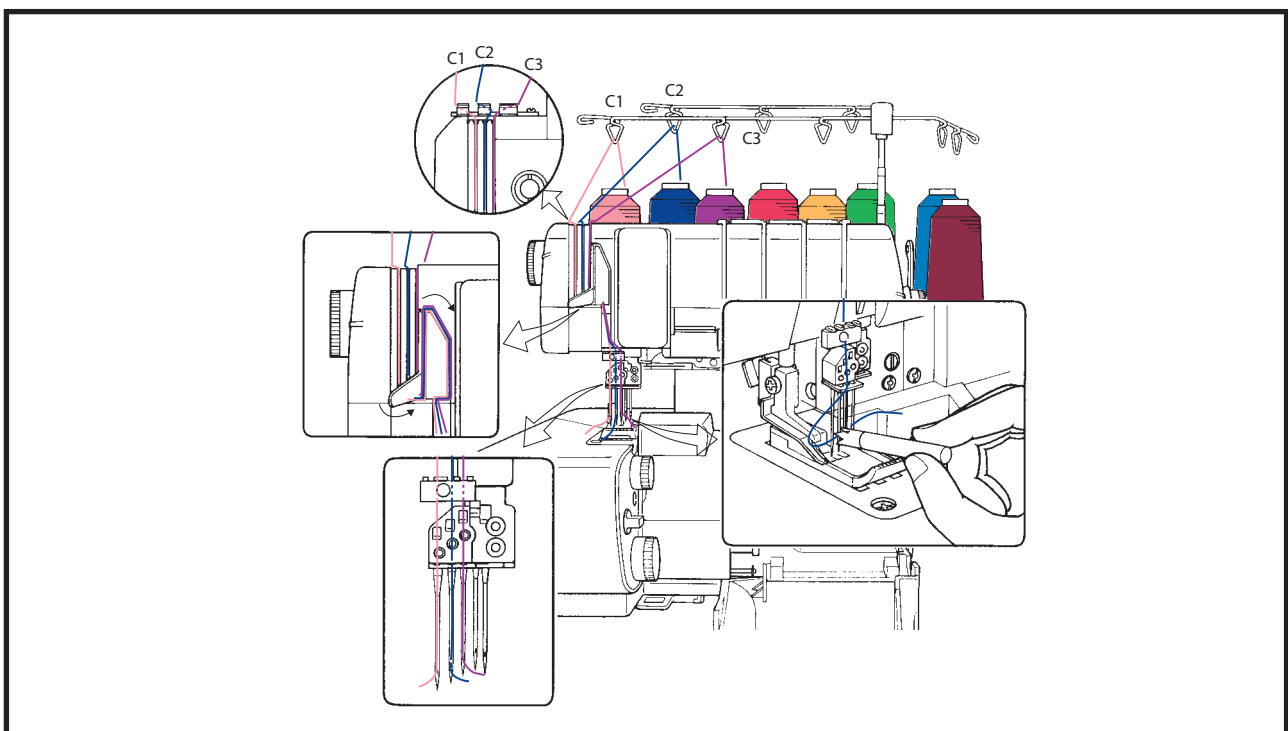

Overlock Needles

Left Overlock Needle - O-1

1. Place the thread on the "OVERLOCK NEEDLE 1" spool pin (fig. C, page 19). Bring the thread end through the telescopic guide directly above the thread. Bring the thread through thread guide at top of machine and down the "overlock needle 1" thread path and in the guide just below the faceplate. Pull an 8 inch (20cm) length of thread through the guide. Follow the arrows as shown in the illustration. Thread the guides above the needle.
2. Using the needle threader or tweezers, thread into the eye of O-1 needle.

Right Overlock Needle - O-2

1. Place the thread on the "OVERLOCK NEEDLE 2" spool pin (fig. C, page 19). Bring the thread end through the telescopic guide directly above the thread. Bring the thread through thread guide at top of machine and down the "overlock needle 2" thread path and in the guide just below the faceplate. Pull an 8 inch (20cm) length of thread through the guide. Follow the arrows as show in the illustration. Thread the guides above the needle.
2. Using the needle threader or tweezers, thread the eye of O-2 needle.

Note: Make sure that each needle is set for overlock stitching; right needle is O-2 and left needle is O-1.

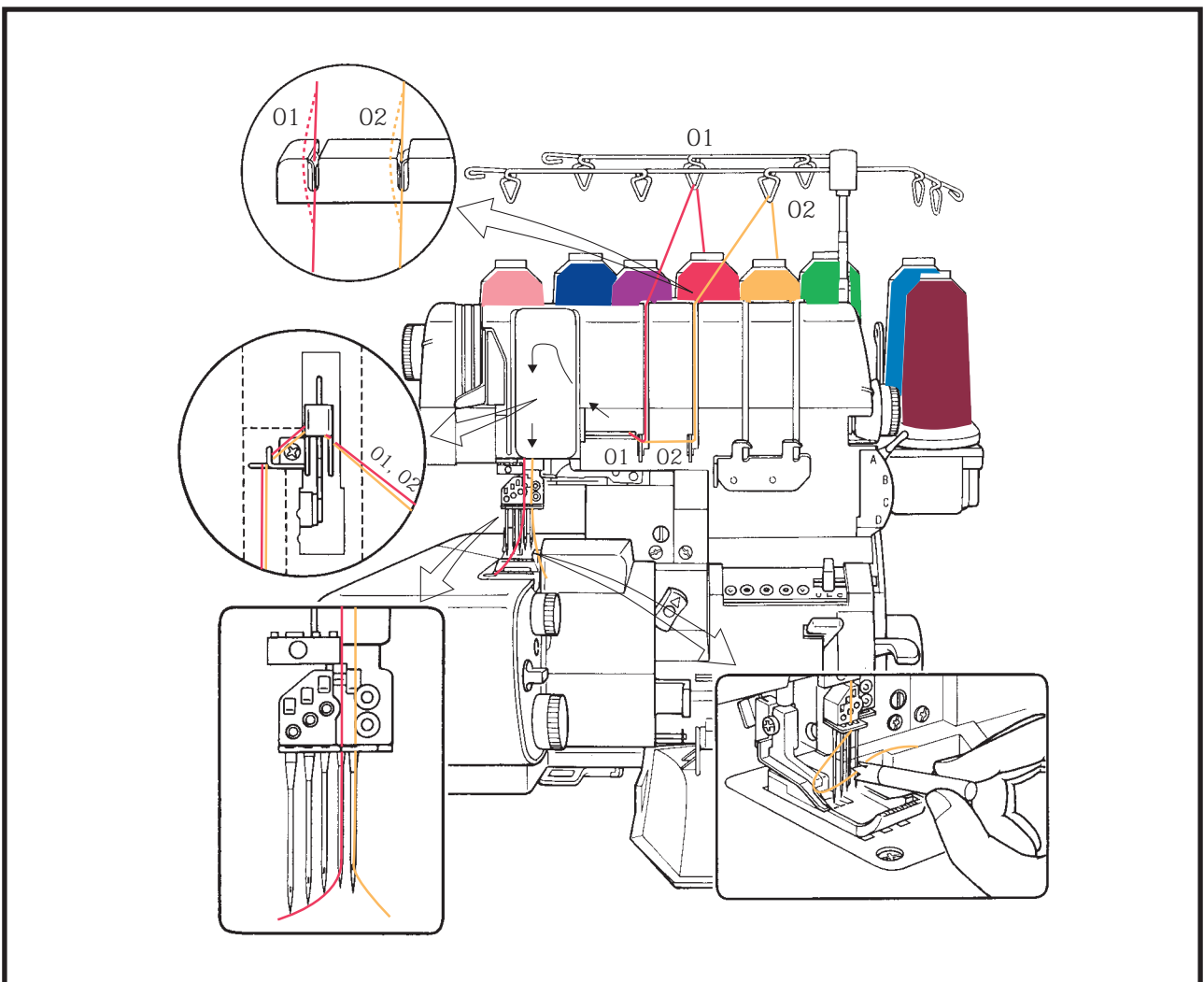

How To Use The Needle Threader

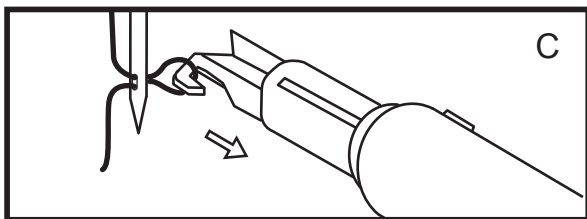
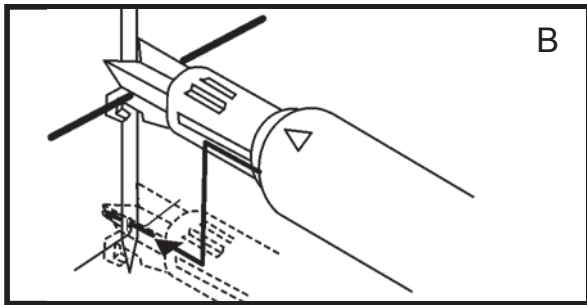
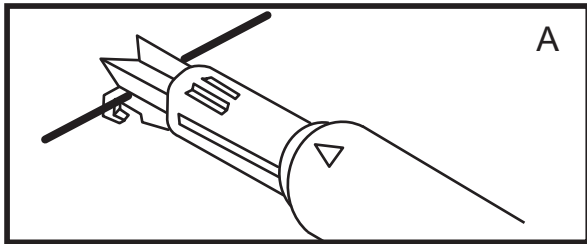

1. Hold the needle threader with the arrow mark on top. Place the thread in the groove of the needle threader. (fig. A)
2. Push the needle threader against the needle shaft above the eye of the needle and then slide down the groove of the needle to the eye. Gently push on the needle threader until the thread is inserted through the eye of the needle and then slowly remove while leaving the thread loop through eye. (fig. B)
3. Using the hook located at the grooved end of the needle threader or the tweezers pull the loop of thread from the back of the needle, place under the foot and to the back left. (fig. C)

Front Cover Seam Guide

Use the marks on your serger's front cover to align the fabric the desired seam width. Set the width dial at the "M" setting for accurate seam allowances.

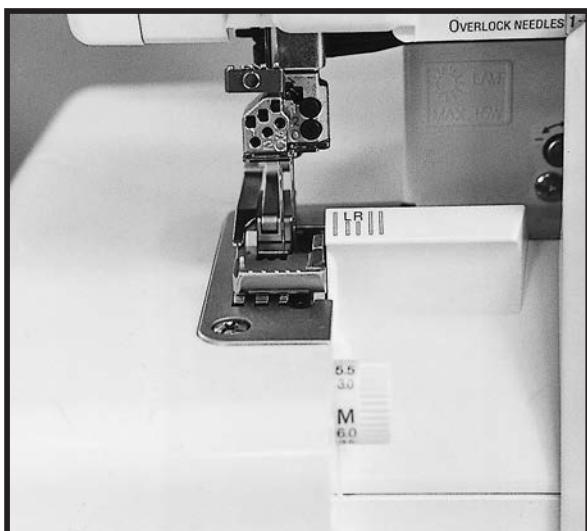

1. The chain stitch (C-3) combined with the 3-thread overlock is the most common 5-thread combination. The mark closest to the needles indicates 5/8 inch (16mm) from the cutting edge to the C-3 chain needle.
2. When using the left overlock needles (O-1) for either a 3 or 4-thread overlock seam, the second mark from the needles indicates 5/8 inch (16mm) from the cutting edge to the O-1 overlock needle.
3. Use the right overlock needle (O-2) for 3-thread overlock seam and the third mark from the needles indicates 5/8 inch (16mm) from the cutting edge to the O-2 overlock needle.
4. Other marks on the front cover are for any custom seam allowance.

Note: Be sure to set the width dial at the "M" setting for accurate seam allowances.

Start to Sew

When threading is complete, the loose threads should initially interlock on fabric. This is most important when sewing the chain or cover stitches.



1. Cut all threads to 4 inch (10cm) in length.
2. Place fabric under the presser foot directly below the needles (fig. A).
3. Lower the presser foot.
4. Turn the handwheel toward you to form 2 or 3 stitches.
5. Start to sew slowly.
6. After the first few stitches, stop and cut excess threads (fig. B).
7. Start the next seam at the toe of the presser foot (fig. C).
8. You only need to raise and lower the presser foot when working with thick fabrics or when precise positioning is required.



Note: Be careful not to push or pull the fabric. The evolve will feed it evenly without help.

To Chain-Off of the Fabric

Your evolve will sew a chain off the edge of the fabric. For best results, we recommend to follow the instructions below.

Overlock stitches-

1. At the end of the seam, gently pull the fabric and thread to the back to chain-off (fig. A).
2. When the desired length is reached, cut the thread chain with the thread cutter located on the left side cover (fig. B).
3. Start the seam by placing the fabric under the front of the foot (fig. C).

Chain/Cover stitches-

1. At the end of the seam, change the stitch length to 4 and chain needle tension set at a range from 2 to 0.
2. Let the thread flow from the back of the foot 2-4 inches without pulling.
3. Start the seam by placing the fabric under the front of the foot.

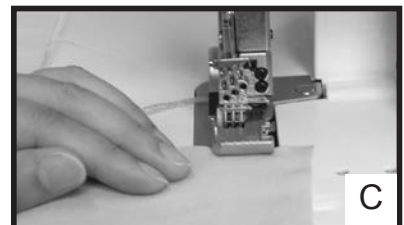

Clearing the Stitch Width Fingers

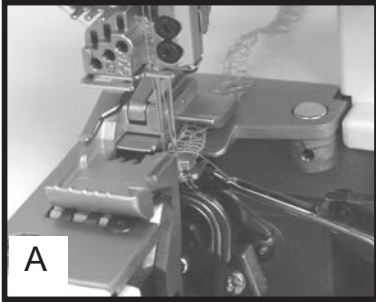

As you sew, you will discover that maneuvering the fabric is different from conventional sewing because the threads form around the stitch fingers (fig. A).

To clear the stitch fingers, simply raise the presser foot, which releases all threads. Raise the needle(s). Then pull the threads gently from behind the foot (fig. B). The stitches are now released from the fingers (fig. C).

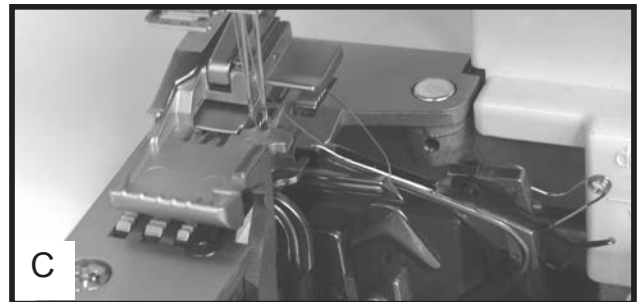

Re-threading Loopers

If a thread breaks, raise the presser foot and pull the broken thread from under the foot. Open the front cover, depress the machine lock button and set the looper threader selector to U, L, or C for the looper being threaded. Re-thread the machine above the threading port, leaving an 18inch (40cm) thread tail. Thread the looper as usual and move lock button release lever to the right. Close the front cover and sew a test sample.

Note: When re-threading your Baby Lock evolve using the "Jet-Air Threading" feature, make sure that the previous thread that was in the looper (tube) is completely removed. This will eliminate any chance of the previous thread obstructing the flow of the air when re-threading the machine.

4-Thread Overedging

Overedging to finish facings, hems and seams before construction, is one of the most basic uses of a serger, such as making a garment or project with 5/8 inch (16mm) pressed open seams (fig. A).

To overedge, place the single layer of fabric in front of the presser foot, aligning the cut edge with upper cutting blade. Begin sewing, continuing to guide the fabric along the blade. The edge of the fabric should be trimmed, but not cut away. Then sew the seams on your conventional sewing machine and press them open as usual (fig. B).

Because notches would be cut away in this process, mark them before sewing with "V" snips just inside the seam allowance or with a water-soluble fabric marker (fig. C).

Note: A 2-thread overlock or 3-thread overlock can also be used with this technique.

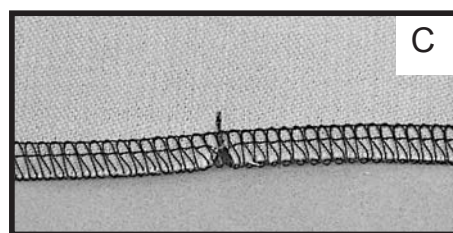
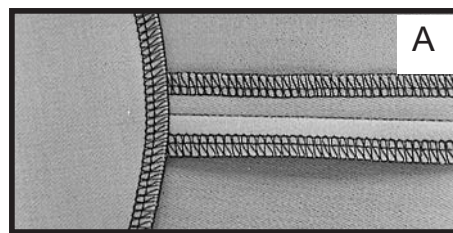

Overlock Seam

For garments or projects that do not require conventional pressed-open seams, you can stitch and finish the seam in one operation and then press the seams to one side (fig. A). A 4 or 3-thread seam is strong, yet it provides "give" or flexibility according to the needs of the fabric.

Place two layers of fabric right sides together. Use the marks on your serger's front cover to align the fabric for the desired seam width. Keep your eye on the fabric edge to guide it to the appropriate mark (fig. B).

Do not watch the needle. If you guide the fabric accurately, the needle will seam in the correct place automatically.

Note: For most seaming, pins are unnecessary because the serger feeds the fabric evenly. If you need pins, place the pins parallel to the seam line outside the seam allowance to avoid damaging the blades.

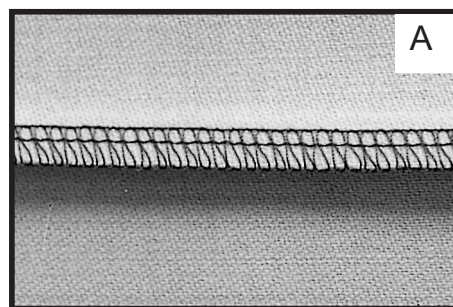

4-Thread Overlock

With the evolve overlock Thread Delivery System, the upper and lower looper threads lock together evenly over the cut fabric edge(s) to form a flat, non-rolling pattern of overlocking stitches on both sides of the fabric.

The left (O1) needle thread interlocks with both looper threads at the stitching line to create the seam. The right (O2) needle thread, visible on the top side of the stitch, interlocks with both the loopers to add durability. The thread, that resembles a zigzag on the upper side of the fabric, is from the upper looper. The thread, that resembles a zig zag on the lower side of the fabric, is from the lower looper.

Move the stitch selector lever to "A".

For the perfect 4-thread overlock stitch, follow the suggested settings and threading diagram below.

NEEDLES O-1, O-2	LENGTH 2,5 – 3,5	WIDTH 6,5 – 7,5	STITCH SELECTOR A
---------------------	---------------------	--------------------	-------------------------

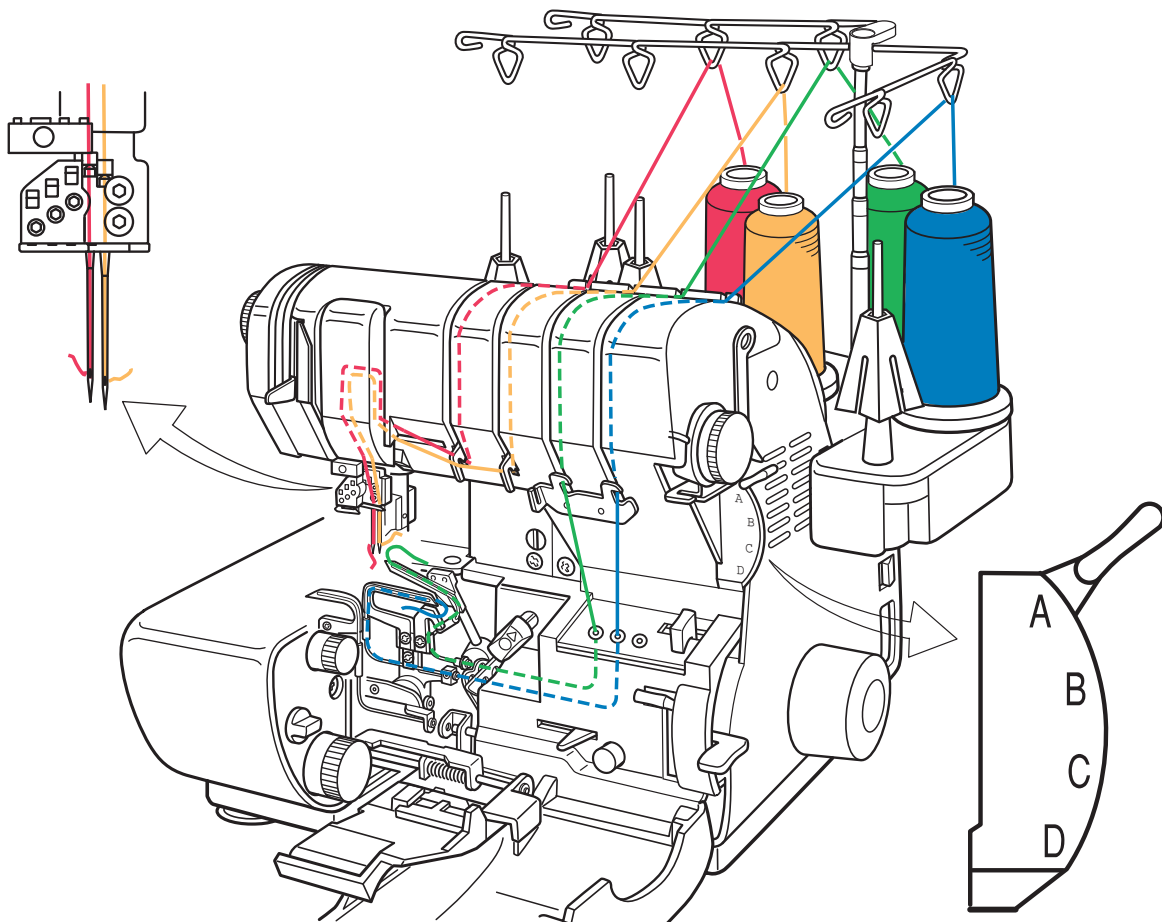

3-Thread Overlock-Wide

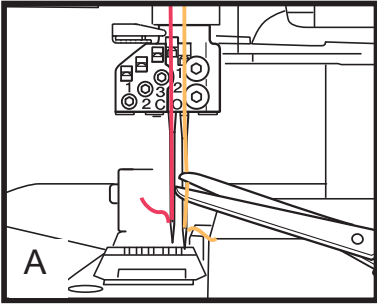

The 3-thread overlock wide stitch is perfect for edge-finishing most woven fabrics and for seaming knits that do not require the extra durability that a fourth thread provides.

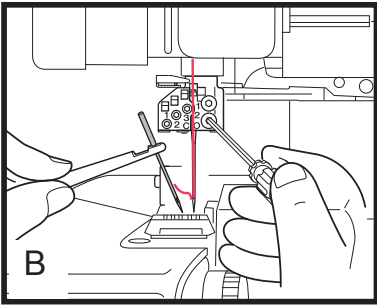

To convert your serger to a 3-thread overlock wide (5,5-7,5mm), cut the O-2 needle thread just above the needle eye (fig. A). Remove the O-2 needle and thread completely from the machine. Re-tighten the needle clamp screw slightly to prevent the screw from working out (fig. B).

Move the stitch selector lever to "A".

For O-1 needle, 3thread overlock, follow the suggested settings and the threading diagram below.

NEEDLES O-1	LENGTH 2 – 3	WIDTH 7,5	STITCH SELECTOR A
----------------	-----------------	--------------	-------------------------

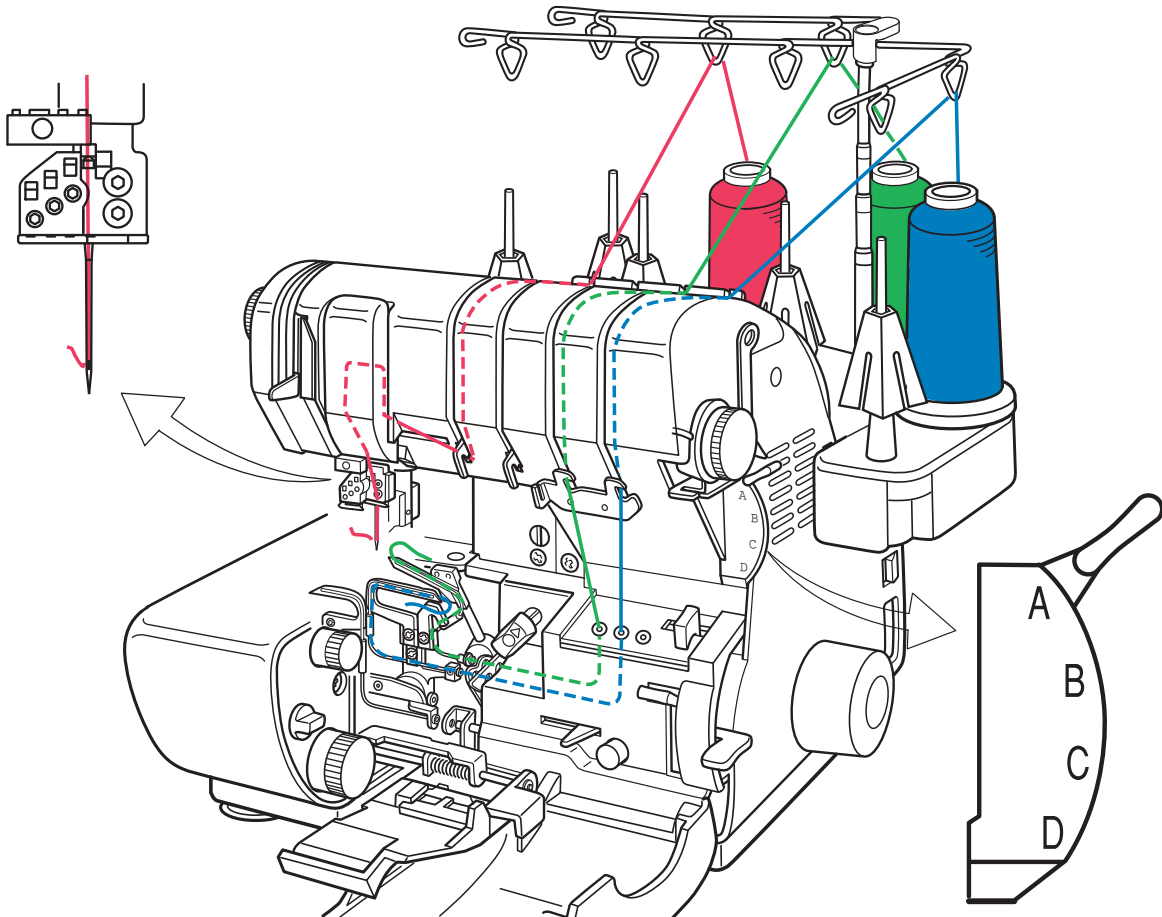

3-Thread Overlock-Narrow

To convert to narrow 3-thread overlock (3,0-5,0mm), cut the O-1 needle thread (fig. A). Remove the O-1 needle and O-1 needle thread completely from the machine.

Tighten the needle clamp screw slightly to prevent the screw from working out (fig. B).

Place needle into O-2 needle clamp position and tighten screw. Move the stitch selector lever to "B".

For the O-2 needle, 3-thread overlock sewing, follow the suggested settings and the threading diagram below.

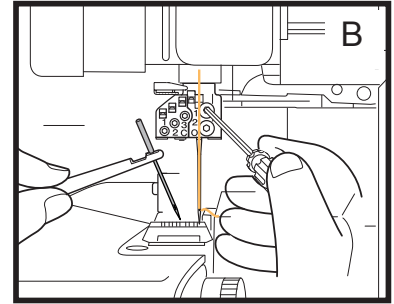
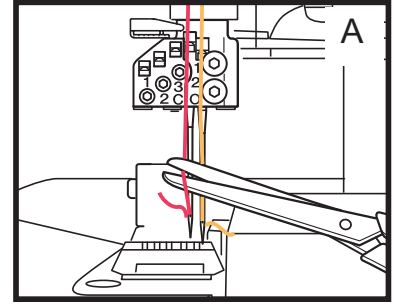

NEEDLES O-2	LENGTH 2,5 – 3,5	WIDTH 3,0	STITCH SELECTOR B
----------------	---------------------	--------------	-------------------------

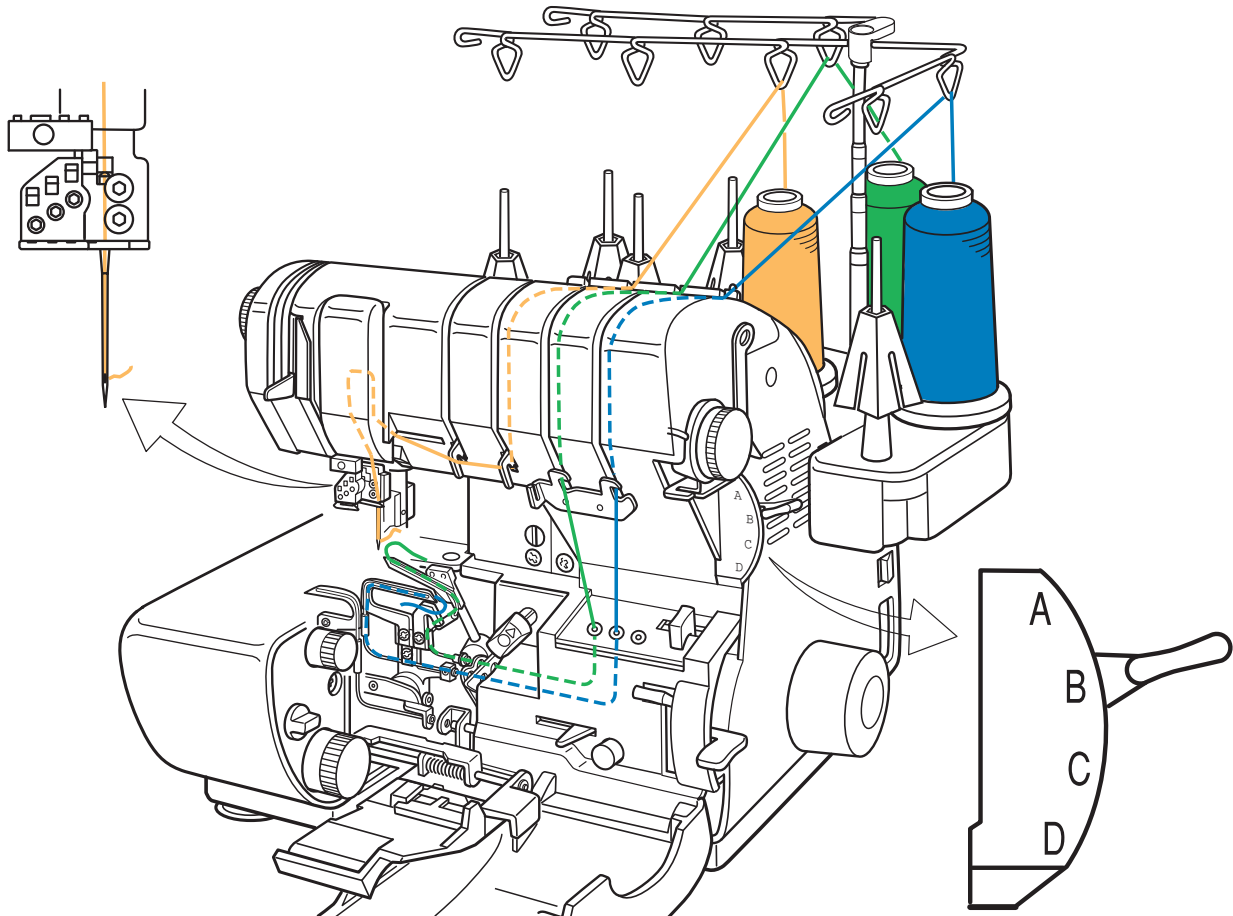

3-Thread Overlock-Narrow Hemming

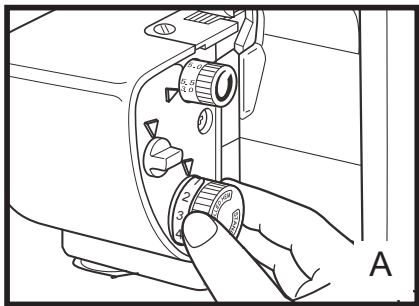

Narrow Hemming is an attractive finish for light to medium weight fabrics.

Remove the O-1 needle and needle thread completely from the machine. Clear the stitch fingers. Turn the stitch length adjusting dial clockwise to the rolled hem range. Set the length at "1" (fig. A) and the stitch width at 3,0 for a smooth decorative finish (fig. B).

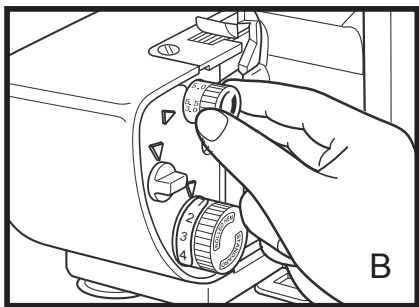

Move the stitch selector lever to "C".

For the O-2 needle 3-thread narrow hemming, follow the suggested settings and the threading diagram below.

NEEDLES O-2	LENGTH 0,75 – 1,5R	WIDTH 3,0	STITCH SELECTOR C
----------------	-----------------------	--------------	-------------------------

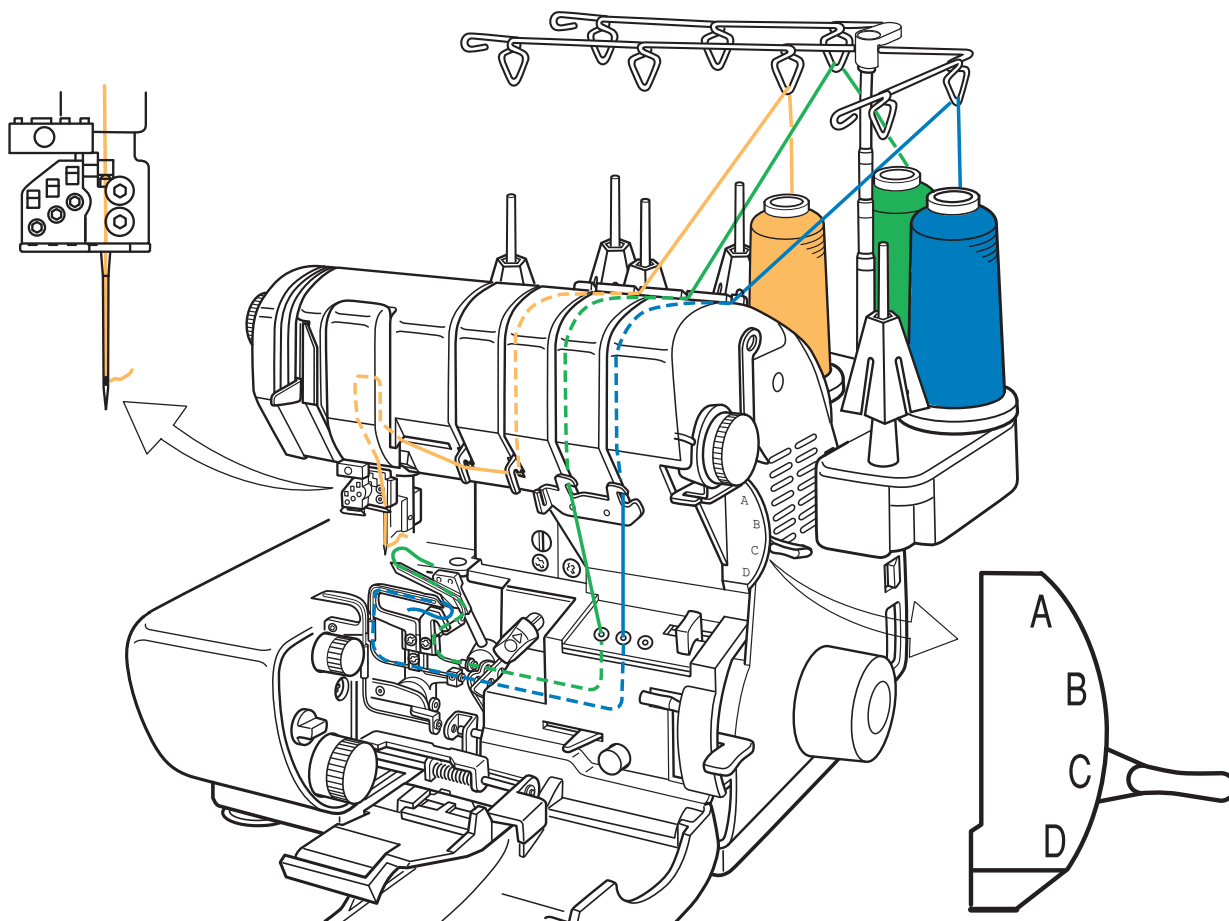

Rolled Edging

The rolled edge setting is used to achieve the narrowest stitch possible (1,5mm) on your Baby Lock serger. The stitch is suitable for seaming sheer and lightweight fabrics and for edging and hemming lightweight fabrics.

3-Thread Rolled Edge

With the stitch selector set on "D", a narrow hem can become a rolled edge. The fabric edge rolls around the stitch finger. The upper looper wraps the fabric edge while the lower looper thread is nearly invisible on the back side of the stitch formation.

Remove the 0-1 needle and thread. Clear the stitch fingers. Turn the stitch length adjusting dial clockwise into the rolled hem range and the dial at 1,5 (fig. A). Set the stitch width dial to 3,5 "M" (fig. B).

For a 3-thread rolled edge, Move the stitch selector lever to "D".

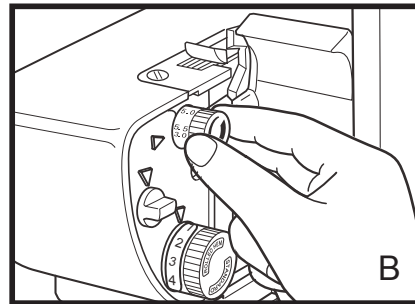
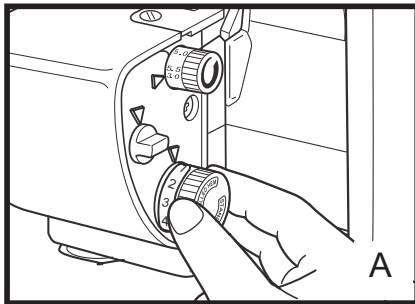

NEEDLES O-2	LENGTH 0,75-1,5R	WIDTH 3,5	STITCH SELECTOR D
----------------	---------------------	--------------	-------------------------

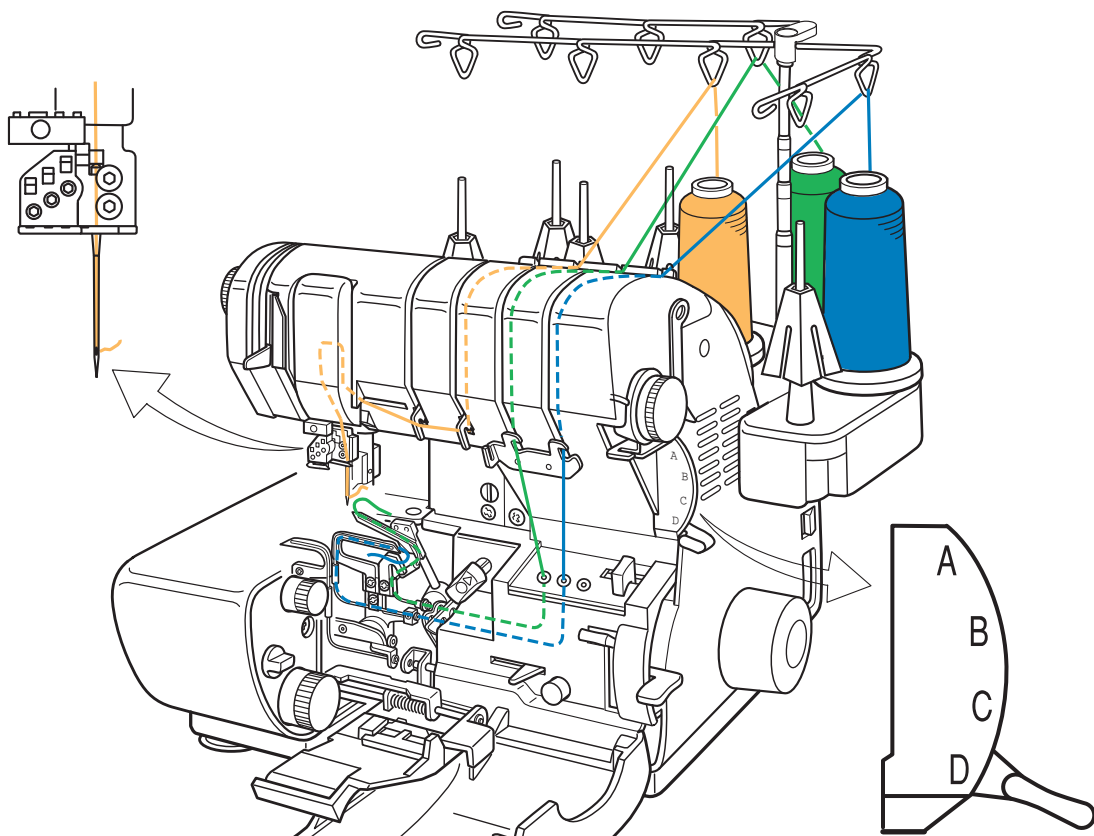

Seaming Sheers

Use the 3-thread rolled hem setting when sewing sheer fabrics. Set the stitch length at 2,5. Sew the seams, aligning the fabric edge with the serger's seam guides, trimming away the excess seam allowance.

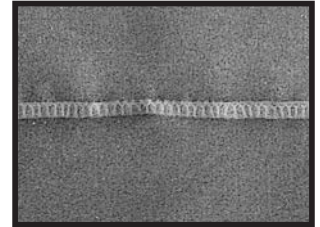

Lettuce Edge

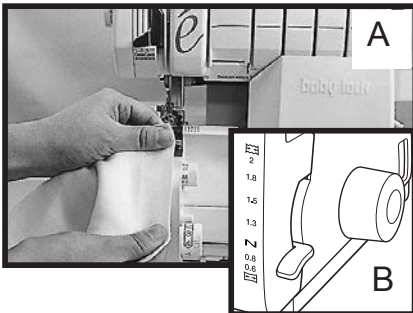

A frilly or "lettuce" edge can be created on most light and medium weight stretch and on bias edges of soft, woven fabrics. It makes a pretty decorative edging for activewear, lingerie, accessories and children's wear.

Set the machine for the 3-thread rolled edge. Set differential feed at 0,6 (fig. B). Sew the fabric in the direction of greatest stretch—the crossgrain on knits, bias grain on wovens. For a "leafier" effect, try using a shorter stitch length and gently stretch the fabric (fig. A) as it is being sewn. Sew a test sample (fig. C).

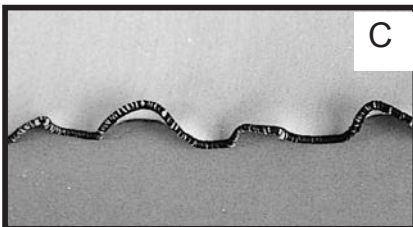

Belt Loops and Button Loops

Use the rolled edge thread chain, stitched without fabric, to make professional belt loops and button loops. Using heavier decorative thread gives a stronger loop.

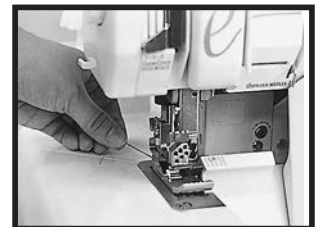

Returning to Standard Serging

Clear the stitch fingers and return the stitch length dial to the standard range. Set stitch width and length at the desired settings. Replace the left needle and its corresponding thread, if desired.

3-Thread Flatlock - Narrow

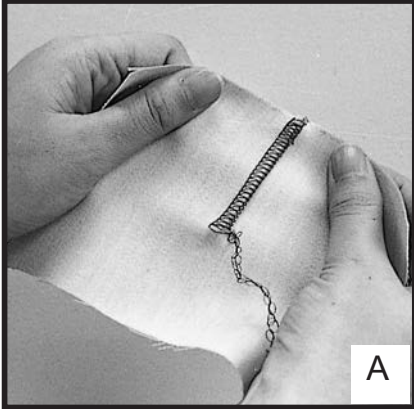

Flatlock seams are most suited to fabrics which do not ravel such as interlock knits, tricot, sweatshirt fleece and synthetic suede. The needle thread is carried below the fabric and to the cut edge of the fabric. The lower looper thread rides along the cut edge of the fabric for stability. The edges pull open and flatten within the stitch for a non-bulky join (fig. A). Be sure to sew a test sample first to determine whether the stitch will have the strength to hold the seam without the fabric pulling away.

Move the stitch selector lever to "D".

For the O-2 needle 3-thread flatlock, follow the suggested settings and the threading diagram below.

NEEDLES O-2	LENGTH 2 - 3	WIDTH 3,0-5,0	STITCH SELECTOR D
----------------	-----------------	------------------	-------------------------

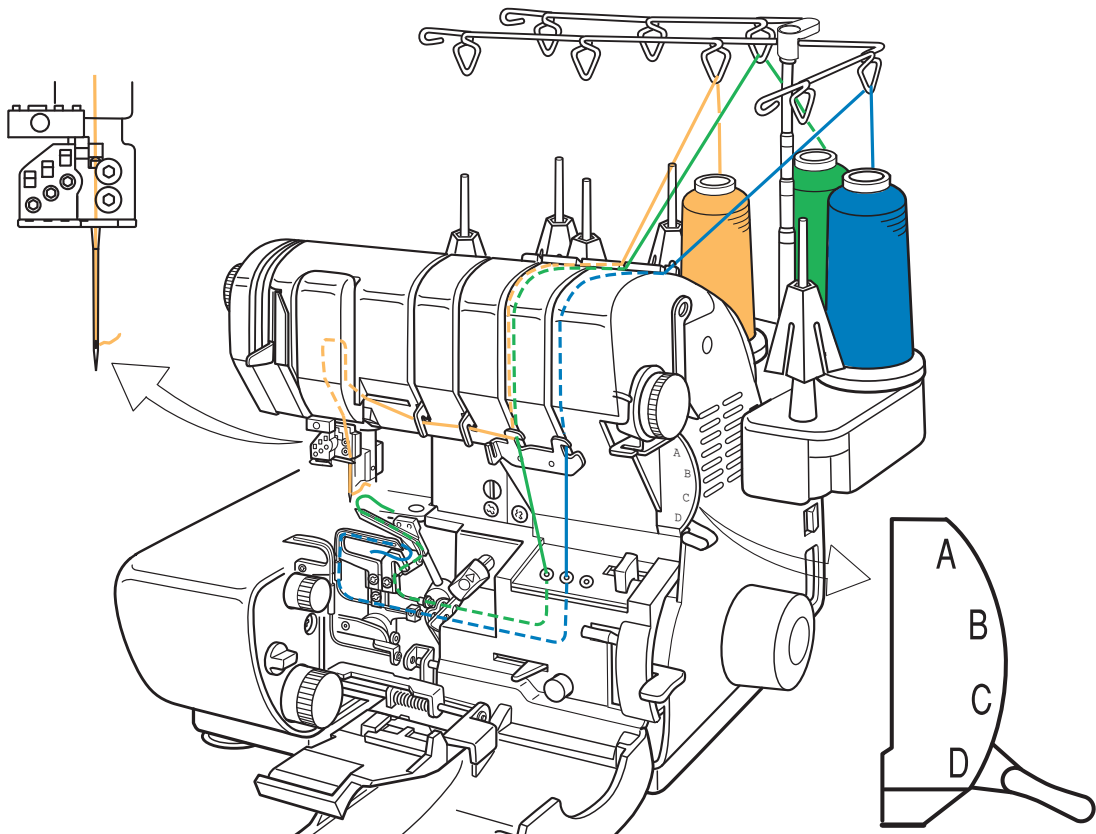

2-Thread Overlock

The 2-thread function provides an economical and less bulky means of overedging all fabrics.

The standard 2-thread overlock is the same as a 2-thread flatlock stitch.

When sewn with specialty threads, 2-thread sewing makes decorative seams and edges for activewear, children's clothing, ruffles, and hemlines.

Converting from 3-thread to 2-thread Overlock

Either overlook needle may be engaged for 2-thread overlock sewing.

1. Open the front cover and the blade cover, cut the upper looper thread just above the threading port (fig. A). Raise the presser foot and pull out the clipped thread from under the foot. Remove the upper looper thread from the machine.
2. Place the left needle thread on the "OVERLOCK NEEDLE 1" spool pin (or right needle thread on the "OVERLOCK NEEDLE 2" spool pin) and bring the thread end through the telescopic thread guide directly above the spool of thread. Bring the thread through the top thread guide, down the upper looper thread path and in the guide just below the face plate.
3. Place machine in locked position and set the looper threader selector to "U" (fig. A). Pull out 18 inch (40cm) of thread and put end of thread in the threading port. Press the looper threading lever. Thread will come out of upper looper eye.
4. Unlock the machine to expose the thread. Using your tweezers, pull the thread out of the tubular looper at the lower end of the looper tube. Bring the thread up to the large thread guide below the face plate and to the left under the square guide. Bring the thread up and over the take-up lever slot, down and into the last thread guide above the overlock needles (fig. B).
5. Using the needle threader, thread into the eye of left needle for O-1 on the rear needle holder (or right needle for O-2).
6. Rotate the handwheel to bring the upper looper to its lowest position. Rotate the subsidiary looper up and to the left (fig. C) then slip the end into the upper looper eye (fig. D). Close the blade cover and front cover.
7. The needle and lower looper thread should overcast evenly on the cut edge of the fabric.

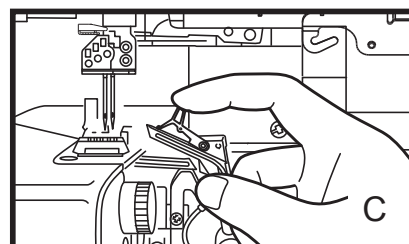
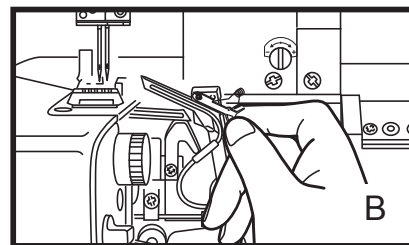
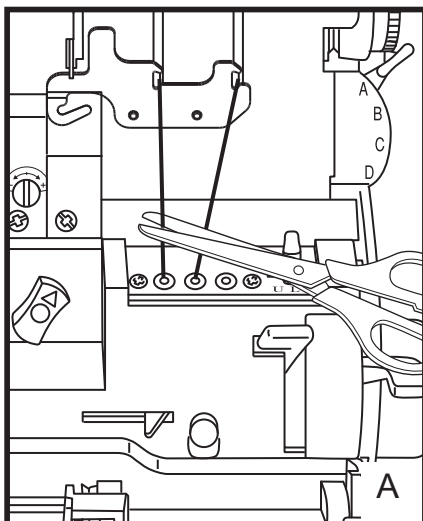

2-Thread Flatlock - Wide

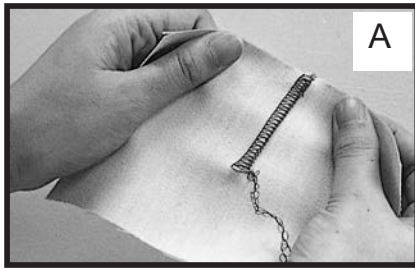

When sewn on a fold, flatlocking can create a decorative effect within the body of a garment or project. Either follow placement lines on your pattern or design your own special effects by stitching the fabric before laying out pattern pieces. Then open the fabric fold until the flatlock stitching lies flat (fig. A).

Be sure to sew a test sample first.

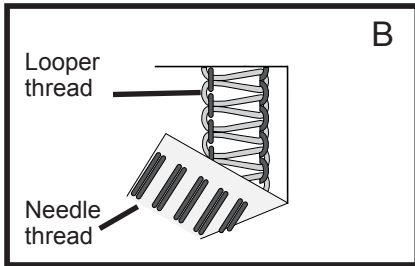

For 2-thread flatlock - wide

1. Lock the machine.
2. Place the needle thread on the "OVERLOCK NEEDLE 1" spool pin.
3. Thread needle thread through the upper looper thread guide on top of the machine, then go down the thread path in the front of the machine. Go left with the needle thread at the hook on front of the machine. Then take the needle thread through the normal needle thread paths (see illustration below).
4. Turn the cutting blade to the "locked" position.
5. Engage the subsidiary looper following step 3 on page 35.
6. Thread the lower looper as shown in the illustration below.
7. Unlock the machine.

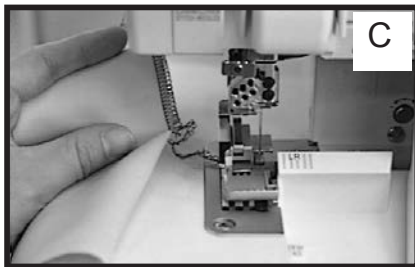

For "loops" (lower looper thread) to show on the right side, place fabric wrong sides together for sewing the seam. To produce the "ladder" (needle thread) on the outside, place the fabric right sides together (fig. B).

Position the fabric under the presser foot, aligning the fold of the fabric 1/8 inch (3,5mm) to the left of the upper cutting blade.

Note: If the fabric does not pull completely flat under the stitches, guide the fabric fold to the left so that the loops hang slightly off the fold as they are being stitched (fig.C).

Move the stitch selector lever to "A" and follow the suggested settings and threading diagram below.

NEEDLES O-1	LENGTH 2 - 2,5	WIDTH 7,5	STITCH SELECTOR A
----------------	-------------------	--------------	-------------------------

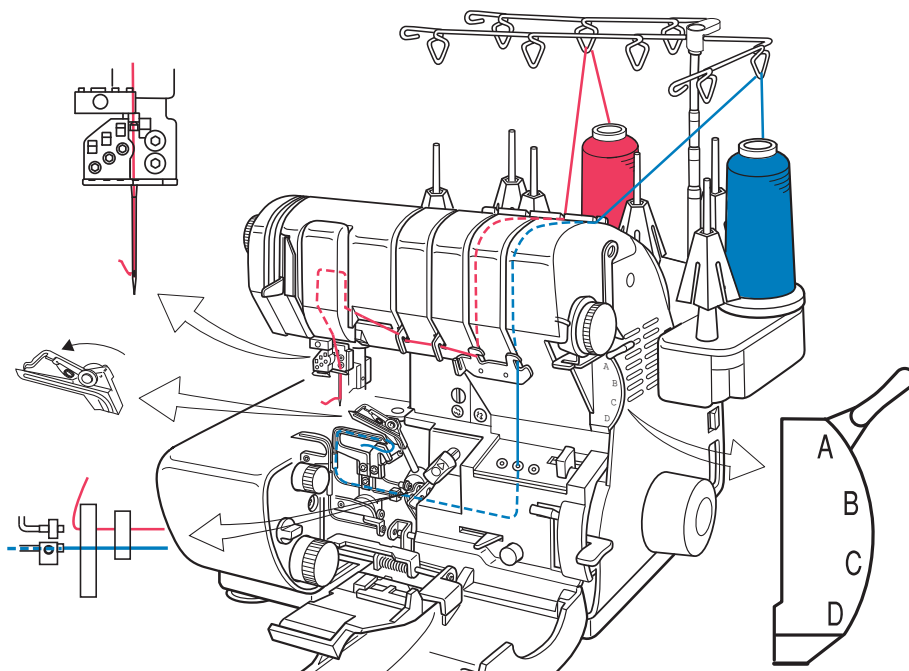

2-Thread Flatlock - Narrow

Sew a 2-thread flatlock seam then pull the two fabric layers apart until the seam lies flat (fig. A). Because the threads show on the outside as well as the inside of the garment or project, the flatlock seam is often considered a decorative application (fig. B).

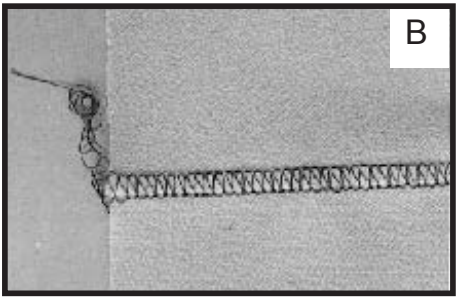
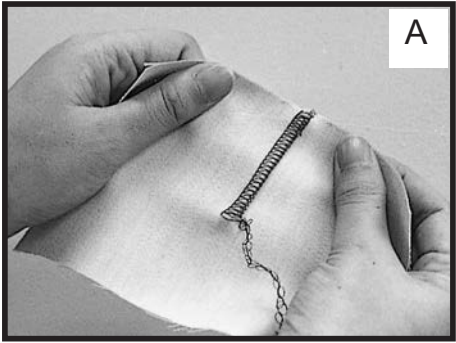

For 2-thread flatlock - narrow

1. Lock the machine.
2. Place the needle thread on the "OVERLOCK NEEDLE 2" spool pin.
3. Thread needle thread through the upper looper thread guide on top of the machine, then go down the thread path in the front of the machine. Go left with the needle thread at the hook on front of the machine. Then take the needle thread through the normal needle thread paths (see illustration below).
4. Engage the subsidiary looper following step 3 on page 35.
5. Thread the lower looper as shown in the illustration below.
6. Unlock the machine.

For "loops" (lower looper thread) to show, place fabric wrong sides together for sewing the seam (fig. C).

To produce the "ladder" (needle thread) on the outside, place the fabric right sides together (fig. D).

For 2-thread flatlock-narrow, follow the suggested settings and the threading diagram below.

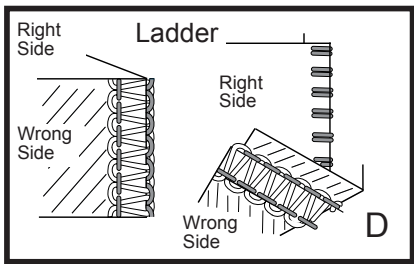
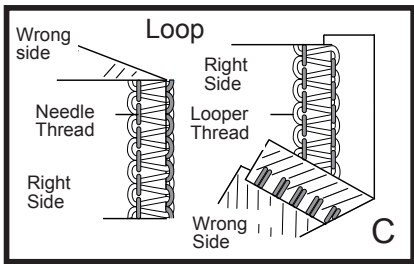

NEEDLES O-2	LENGTH 3 - 3,5	WIDTH 3,5	STITCH SELECTOR B
----------------	-------------------	--------------	-------------------------

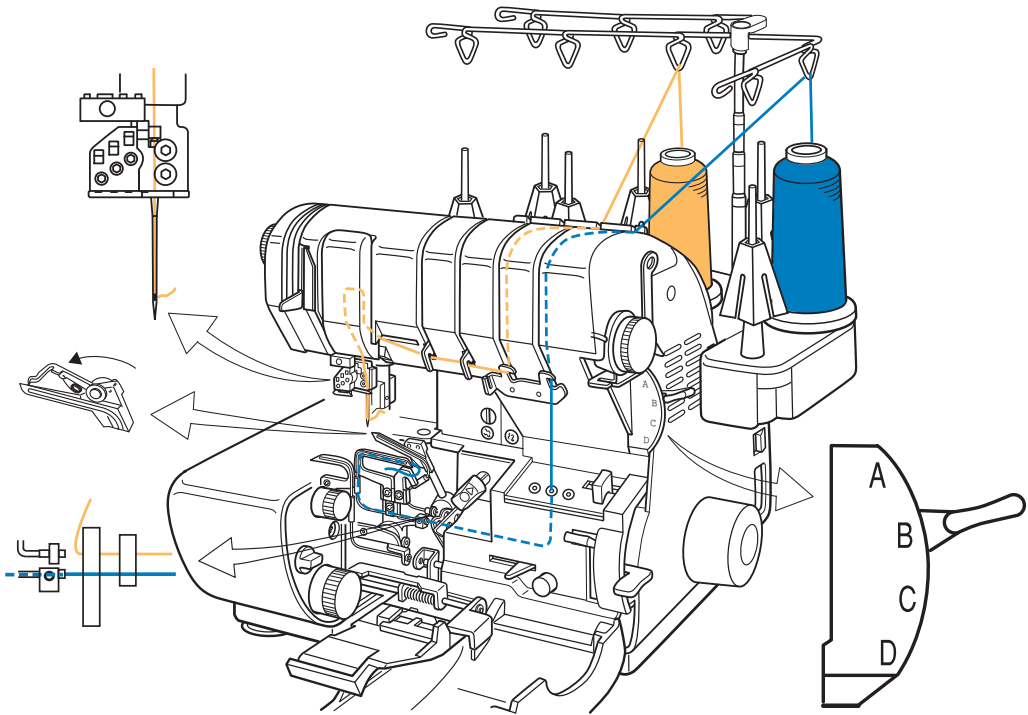

Blanket - Decorative Stitch

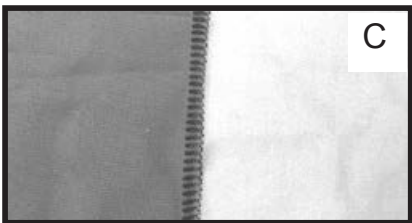
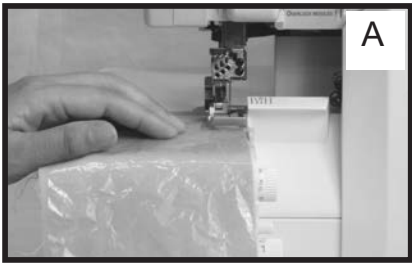

Set up the machine for 2-thread flatlock - wide but the needle threading path is different for this technique.

1. Insert a size 90 top stitch needle in left overlock needle position.
2. Lock the machine.
3. Place a heavy decorative thread that will be used in the needle on "OVERLOCK NEEDLE 1" spool pin and thread the needle thread through upper looper thread path. (See below illustration.)
4. Unlock the machine, pull the thread out of the upper looper tube and continue to thread the needle as illustrated.
5. Thread Maxilock thread in the lower looper.
6. Swing the subsidiary looper into place on the upper looper.
7. Place water-soluble stabilizer on top of the fabric, along the edge.
8. Stitch along the edge of the fabric (fig.A).
9. When finished stitching, pull the water-soluble stabilizer to the edge of the fabric (fig.B). This will pull the stitching to the edge and will look like a blanket stitch (fig.C).

Follow the suggested settings below.

NEEDLES O-1 size 90 Top Stitch Needle	LENGTH 4,0	WIDTH 7,5	STITCH SELECTOR A
---	----------------------	---------------------	---------------------------------

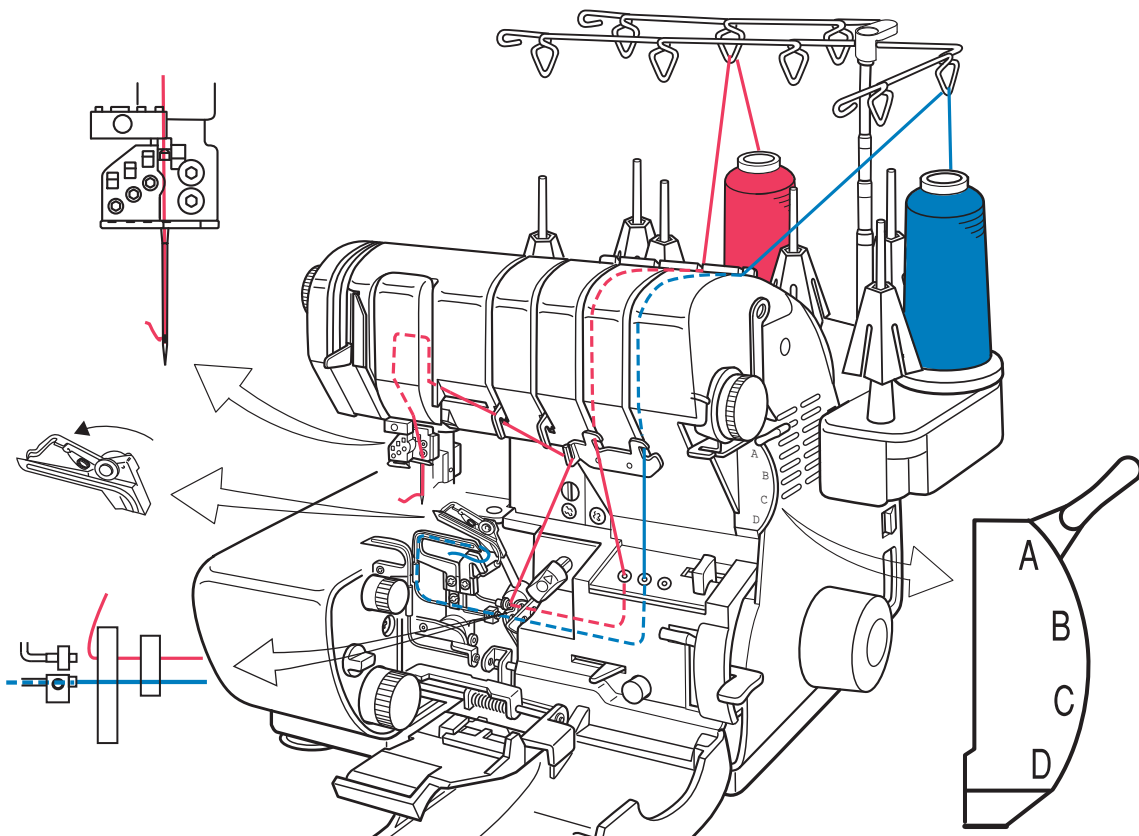

Ladder Stitch - Decorative Stitch

Set up the machine for 2-thread flatlock - wide but the needle threading path is different for this technique.

1. Insert a size 90 top stitch needle in left overlock needle position.
2. Lock the machine.
3. Place a heavy decorative thread that will be used in the needle on "OVERLOCK NEEDLE 1" spool pin and thread the needle thread through upper looper thread path. (See below illustration.)
4. Unlock the machine, pull the thread out of the upper looper tube and continue to thread the needle as illustrated.
5. Thread Maxilock thread in the lower looper.
6. Swing the subsidiary looper into place on the upper looper.
7. Place the fabric pieces right sides together for the decorative ladder to be on the right side of the fabric. (This can also be done on the fold as well.)
8. Sew the fabric together and gently pull open; revealing the decorative ladder stitching on the right side of the fabric.

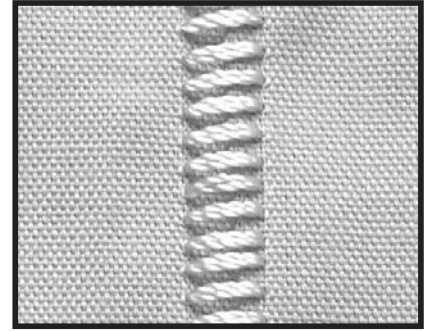
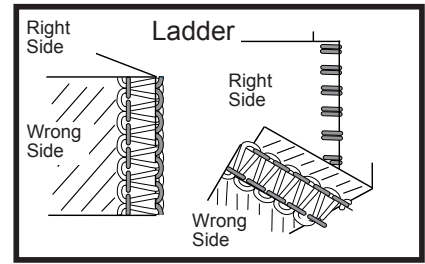

Follow the suggested settings below.

NEEDLES	LENGTH	WIDTH	STITCH SELECTOR
O-1 size 90 Top Stitch Needle	2-3	7,5	A

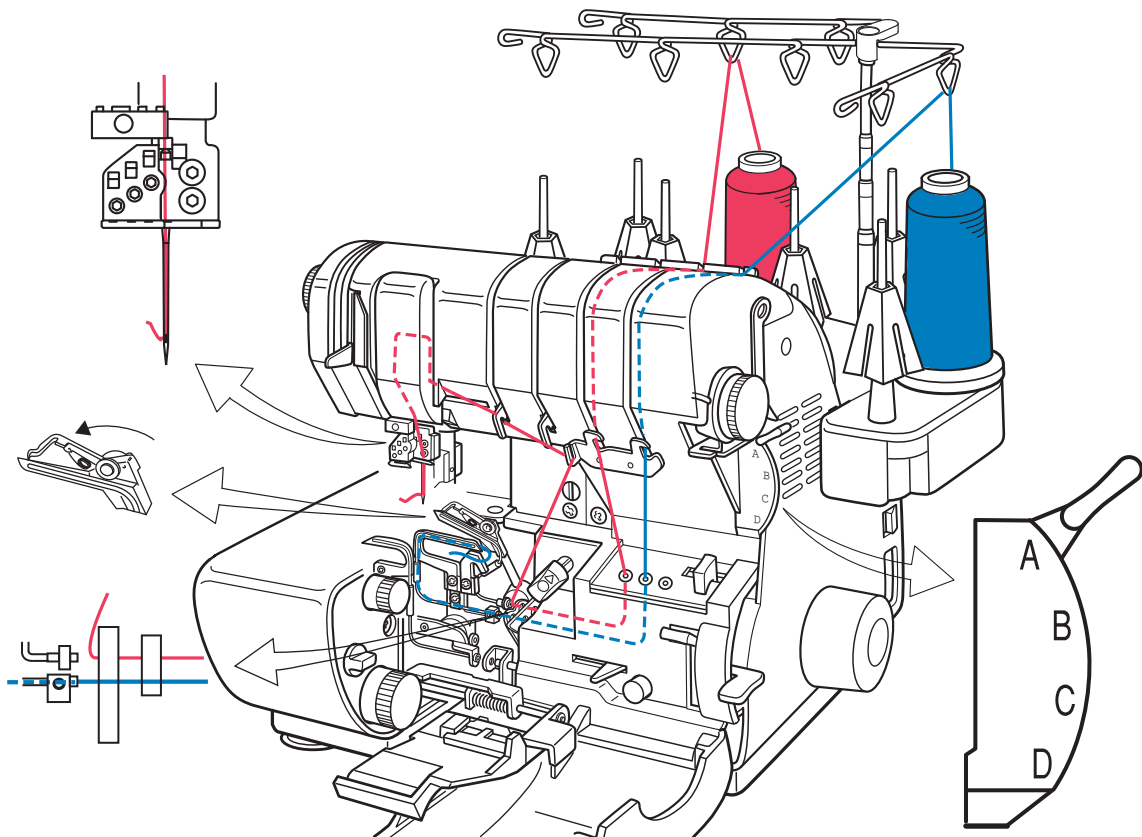

Chain Stitching

The chain stitch is formed using two threads, one thread in the needle and one thread in the chain looper.

Chain Stitching looks like a straight stitch on the top of the fabric while the chain looper thread forms a chain on the underside of the fabric. The chain stitch has stretchability that is not found in the conventional locked straight stitch from a sewing machine. The chain stitch is used to stabilize seams in woven fabrics and where needed in knit fabrics. The chain stitch can also be used for sewing wide elastic in garments and applying bias tape.

For Chain Stitch:

1. Turn the cutting blade to the locked position.
2. Disengage the upper looper by turning the upper looper positioning lever to the "down" position.
3. Place the machine in locked position to thread the chain looper.
4. Select "C" threading port.
5. Follow the diagram to thread the chain looper. Open side cover of machine to make sure the thread is through the eye of the chain looper. Trim thread to 4 inches (10cm) and lay in tray.
6. Follow the guide to thread the chain/cover stitch needle, (C-1, C-2, or C-3). Place needle thread on top and to the left of presser foot before sewing.
7. Set stitch length and other machine adjustments. (See chart below)
8. Move the lock button release lever to the right.
9. Remove the blade cover and attach sewing table. (See page 10)
10. Place the fabric under the needle and turn handwheel toward you two or three stitches in the fabric. Cut the excess threads and start sewing.

Note: All chain and cover stitches must be started with fabric under the needle.

CHAIN STITCH

NEEDLES C-1 C-2 or C-3	LENGTH 2,5 - 4,0	Set Needle Tension Dial to: 4-6	Set Chain Looper Tension Dial to: Chain Stitch
---------------------------	---------------------	---------------------------------------	--

Chain Stitching - continued

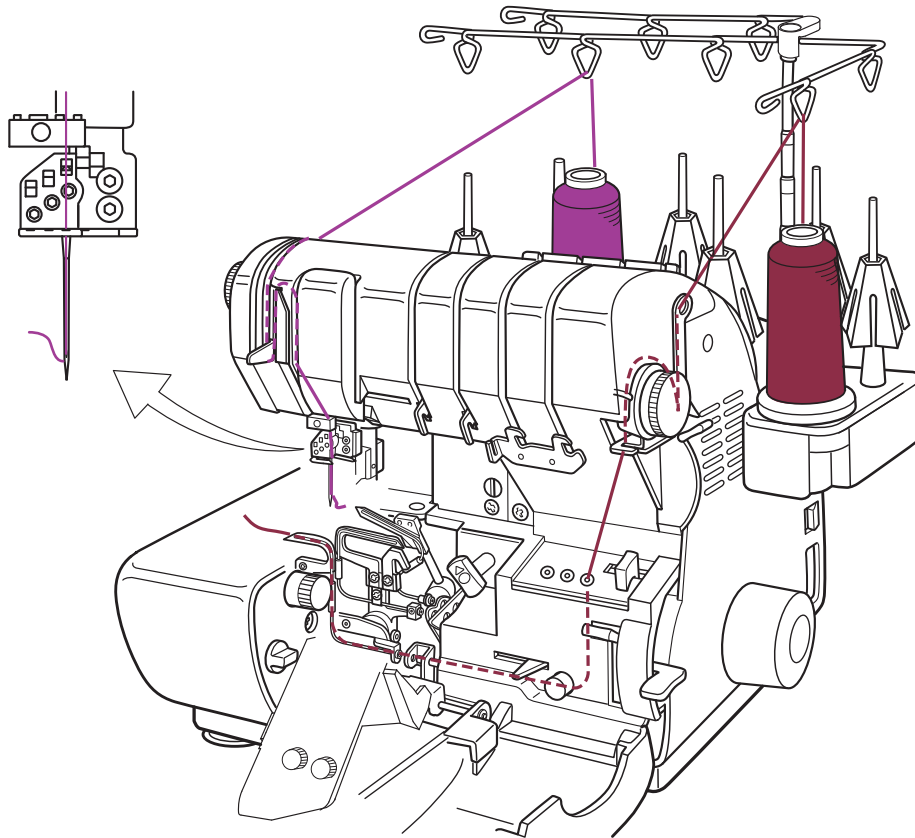

*Tension Adjustment

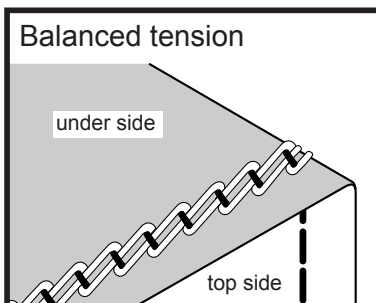

Balanced tension -

Chain stitch has correct tension when the needle thread sews a straight seam on the top side and the chain looper thread forms loops on the under side of the fabric.

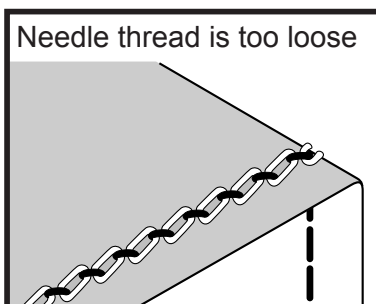

Needle thread is too loose -

Turn the chain/cover needle thread adjusting dial to a higher number. Or turn the chain looper adjusting dial to a narrower dash for looser tension. (Narrow dashes are looser tension)

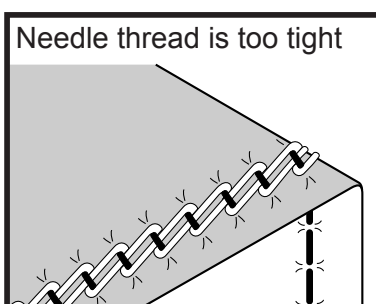

Needle thread is too tight -

Turn the chain/cover needle thread adjusting dial to a lower number. Or turn the chain looper adjusting dial to a wider dash for tighter tension. (Wider dashes are tighter tension)

Cover Stitch - Right Narrow - 3mm

The narrow cover stitch consists of two rows of straight stitching on the top side of the fabric with an overlock stitch on the underside of the fabric. This stitch is very common in the garment industry to hem knit garments. The narrow cover stitch is used on fine knits such as jersey and single knits for hemming or topstitching. The cover stitch is not limited to knit fabrics. It also works well with woven fabrics.

The Right Narrow cover stitch is formed using two "C" needle positions and the chain looper. The needle positions are C-2 and C-3. The width of the narrow cover stitch is 3mm.

For Cover Stitch:

1. Turn the cutting blade to the "locked" position.
2. Disengage the upper looper by turning the upper looper positioning lever to the "down" position.
3. Place the machine in locked position to thread the chain looper.
4. Select "C" threading port.
5. Follow the diagram to thread the chain looper see page 41. Open the side cover of the machine to make sure the thread is through the eye of the looper. Trim thread to 4 inches (10cm) and lay in tray.
6. Follow the diagram to thread the chain/cover stitch needles C-2 and C-3. Place needle threads on top and to the left of presser foot before sewing.
7. Set stitch length and other machine adjustments necessary. (see chart below)
8. Move the lock button release lever to the right.
9. Remove the blade cover and attach the sewing table (pg.10).
10. Place the fabric under the needles and turn handwheel toward you two or three stitches into the fabric. Cut the excess threads and start sewing.

Note: All chain and cover stitches must be started with fabric under the needle.

COVER STITCH - RIGHT NARROW

NEEDLES C-2 and C-3	LENGTH 2,5 - 4,0	Set Needle Tension Dial to: 4-6	Set Chain Looper Tension Dial to: Cover Stitch
------------------------	---------------------	---------------------------------------	--

Cover Stitch - Right Narrow - 3mm - continued

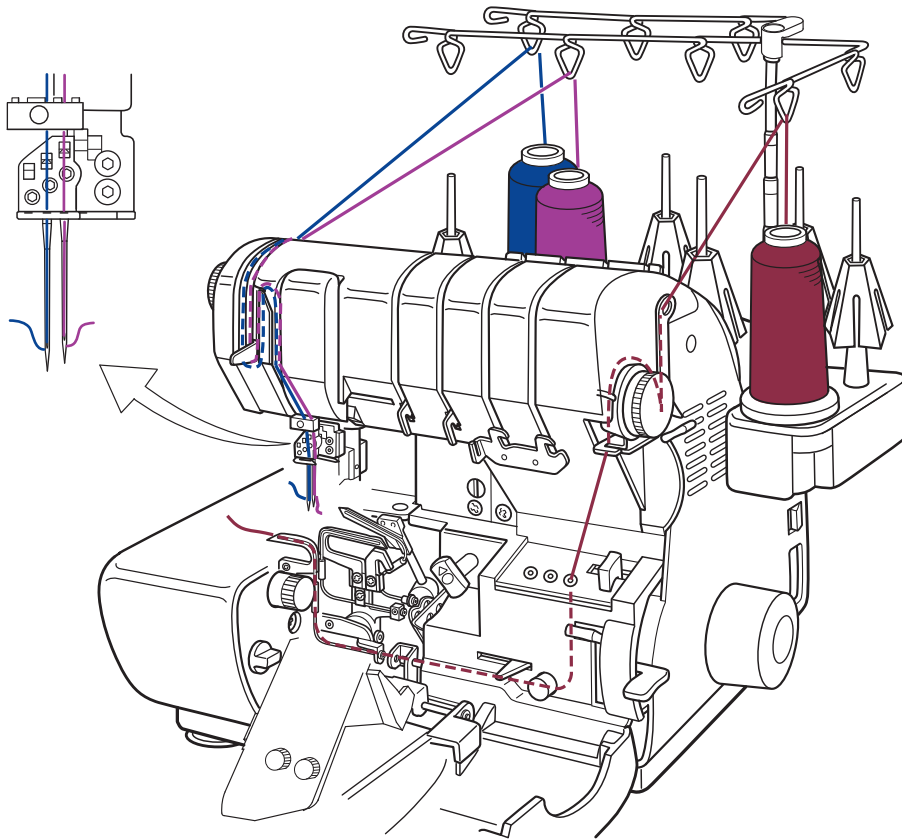

*Tension Adjustment

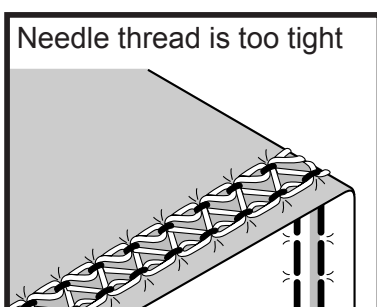
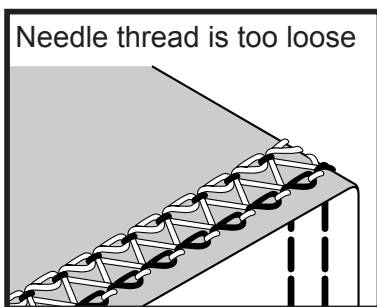
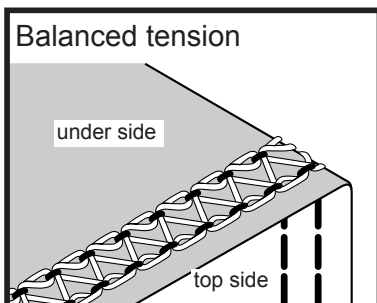

Balanced tension -

Cover stitch has correct tension when the needle thread sews two rows of straight stitching on the top side and the chain looper forms a zig zag on the underside of the fabric.

Needle thread is too loose -

Turn the chain /cover needle thread tension dial to a higher number.

Or turn the chain looper tension dial away from the wide dash at the words "Cover Stitch", but, staying within the solid gold line. This will tighten the chain looper thread on the under side of the stitch.

Needle thread is too tight -

For a looser tension turn the chain /cover needle thread tension dial to a lower number. Make sure that the chain looper tension dial is set at the solid dash at the words "Cover Stitch".

Cover Stitch - Left Narrow - 3mm

The narrow cover stitch consists of two rows of straight stitching on the top side of the fabric with the overlock stitch on the underside of the fabric. This stitch is very common in the garment industry to hem knit garments. The narrow cover stitch is used on fine knits such as jersey and single knits for hemming or topstitching. The cover stitch is not limited to knit fabrics. It also works well with woven fabrics.

The Left Narrow cover stitch is formed using two "C" needle positions and the chain looper. The needle positions are C-1 and C-2. The width of the narrow cover stitch is 3mm.

For Cover Stitch:

1. Turn the cutting blade to the locked position.
2. Disengage the upper looper by turning the upper looper positioning lever to the "down" position.
3. Place the machine in locked position to thread the chain looper.
4. Select "C" threading port.
5. Follow the diagram to thread the chain looper. Open the side cover of the machine to make sure the thread is through the eye of the looper. Trim thread to 4 inches (10cm) and lay in tray.
6. Follow the diagram to thread the chain/cover stitch needle positions C-1 and C-2. Place needle threads on top and to the left of presser foot before sewing.
7. Set stitch length and other machine adjustments necessary. (See chart below)
8. Move the lock button release lever to the right.
9. Remove the blade cover and attach the sewing table (pg. 10).
10. Place the fabric under the needles and turn handwheel toward you two or three stitches into the fabric. Cut the excess threads and start sewing.

Note: All chain and cover stitches must be started with fabric under the needle.

COVER STITCH - LEFT NARROW

NEEDLES C-1 and C-2	LENGTH 2,5 - 4,0	Set Needle Tension Dial to: 4-6	Set Chain Looper Tension Dial to: Cover Stitch
------------------------	---------------------	---------------------------------------	--

Cover Stitch - Left Narrow - 3mm - continued

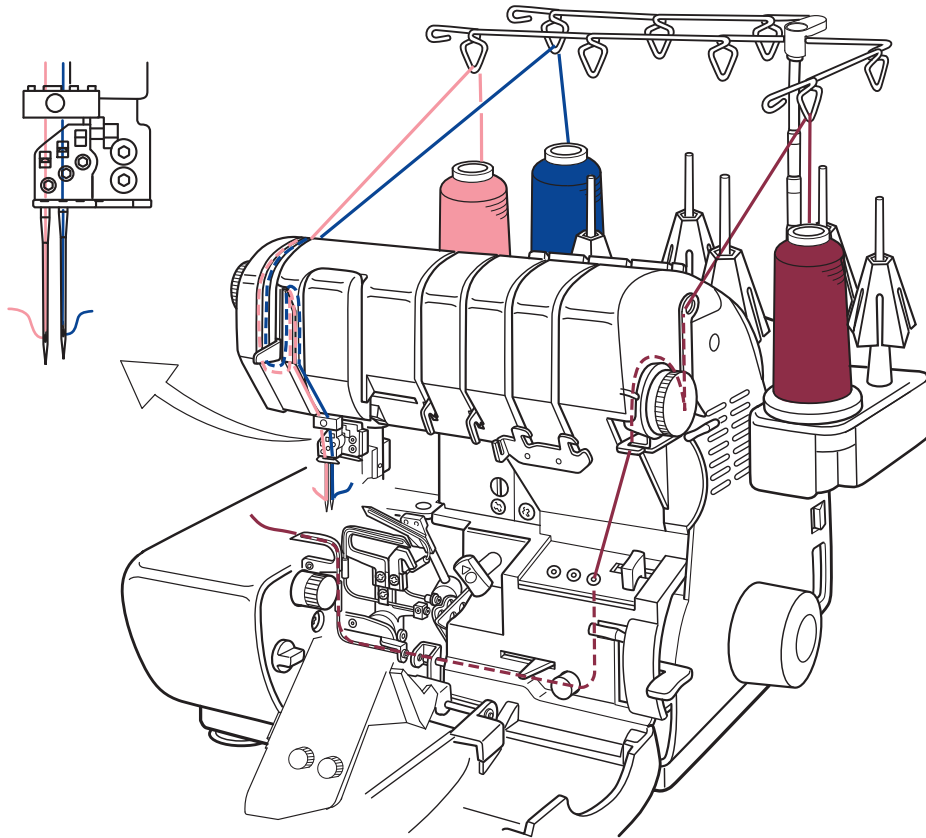

*Tension Adjustment

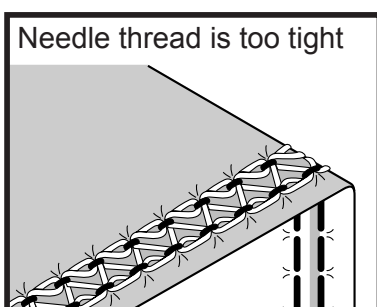
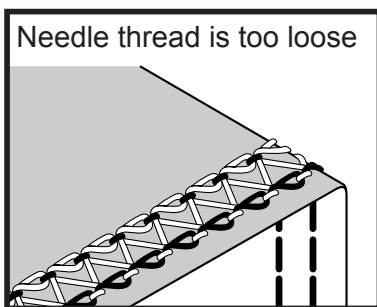
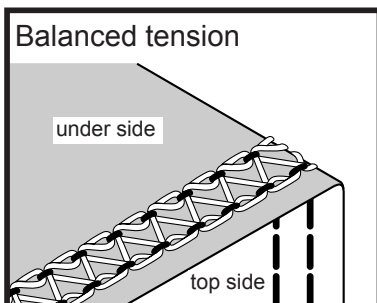

Balanced tension -

Cover stitch has correct tension when the needle thread sews two rows of straight stitching on the top side and the chain looper forms a zig zag on the underside of the fabric.

Needle thread is too loose -

Turn the chain /cover needle thread tension dial to a higher number.

Or turn the chain looper tension dial away from the wide dash at the words "Cover Stitch", but, staying within the solid gold line. This will tighten the chain looper thread on the under side of the stitch.

Needle thread is too tight -

For a looser tension turn the chain /cover needle thread tension dial to a lower number. Make sure that the chain looper tension dial is set at the solid dash at the words "Cover Stitch".

Cover Stitch -Wide - 6mm

The wide cover stitch consists of two rows of straight stitching on top the fabric with an overlock stitch on the underside of the fabric. This stitch is very common in the garment industry to hem heavier knit fabrics such as double knits, sweatshirt fleece, and polar fleece. The wide cover stitch is not limited to knit fabrics. It also works well with medium to heavy woven fabrics.

The wide cover stitch is formed using two "C" needle positions and the chain looper. The needle positions are C-1 and C-3. The width of the wide cover stitch is 6mm.

For Cover Stitch:

1. Turn the cutting blade to the "locked" position.
2. Disengage the upper looper by turning the upper looper positioning lever to the "down" position.
3. Place the machine in "locked" position to thread the chain looper (pg.19).
4. Select "C" threading port.
5. Follow the diagram to thread the chain looper. Open the side cover of the machine to make sure the thread is through the eye of the looper. Trim thread to 4 inches (10cm) and lay in tray.
6. Follow the diagram to thread the chain/cover stitch needle positions C-1 and C-3. Place needle threads on top and to the left of presser foot before sewing.
7. Set stitch length and other machine adjustments. (See chart below)
8. Move the lock button release lever to the right.
9. Remove the blade cover and attach the sewing table. (See page 10)
10. Place the fabric under the needles and turn handwheel toward you two or three stitches in the fabric. Cut the excess threads and start sewing.

Note: All chain and cover stitches must be started with fabric under the needle.

COVER STITCH - WIDE

NEEDLES C-1 and C-3	LENGTH 2,5 - 4,0	Set Needle Tension Dial to: 4-6	Set Chain Looper Tension Dial to: Cover Stitch
------------------------	---------------------	---------------------------------------	--

Cover Stitch - Wide - 6mm - continued

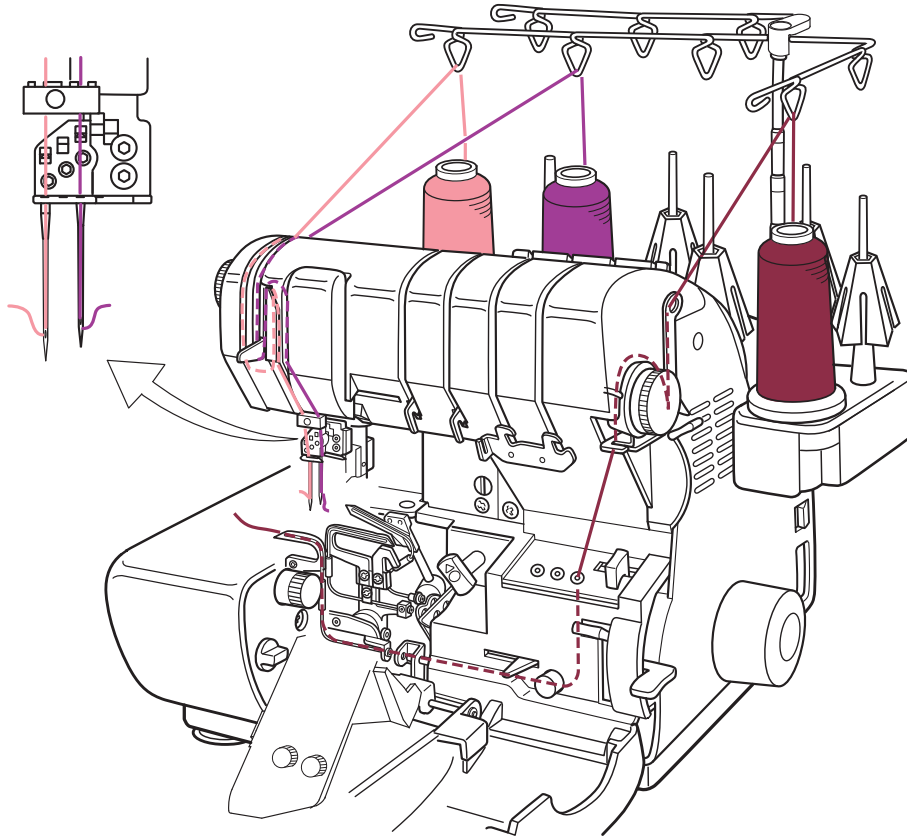

*Tension Adjustment

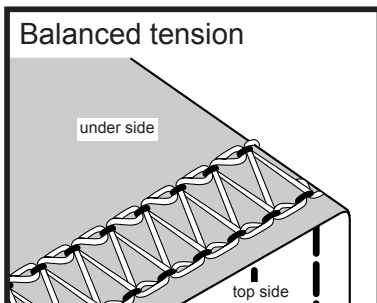

Balanced tension -

Cover stitch has correct tension when the needle thread sew two rows of straight stitching on the top side and the chain looper forms a zig zag on the underside of the fabric.

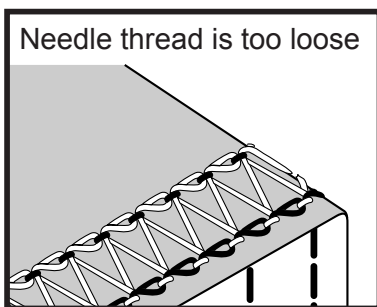

Needle thread is too loose -

Turn the chain/cover needle thread adjusting dial to a higher number. Or turn the chain looper adjusting dial away from the wide dash at the words "Cover Stitch", but staying within the solid gold line. This will tighten the chain looper thread on the under side of the stitch.

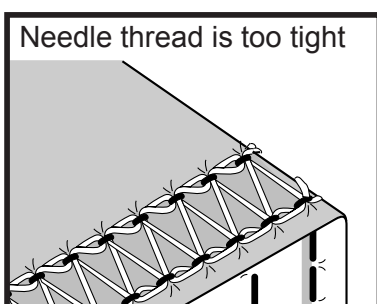

Needle thread is too tight -

For a looser tension turn the chain / cover needle thread adjusting dial to a lower number. Make sure that the chain looper adjusting dial is set at the solid dash at the words "Cover Stitch".

Triple Cover Stitch - 6mm

The Triple Cover Stitch can be used for topstitching, hemming, and elastic application. The stitch can also be used as a decorative stitch upside down with the overlock side on the right side of the fabric. The garment industry uses the Triple Cover Stitch frequently in activewear.

The Triple Cover Stitch is formed using all three "C" needle positions and the chain looper. The Triple Cover Stitch is made up of three rows of straight stitching on the top of the fabric with the chain looper forming an overlock stitch on the underside of the fabric.

For Triple Cover Stitch:

1. Turn the cutting blade to the "locked" position.
2. Disengage the upper looper by turning the upper looper positioning lever to the "down" position.
3. Place the machine in "locked" position to thread the chain looper.
4. Select "C" threading port.
5. Follow the diagram to thread the chain looper. Open the side cover of the machine to make sure the thread is through the eye of the looper. Trim thread to 4 inches (10cm) and lay in tray.
6. Follow the diagram to thread the chain/cover stitch needle positions C-1, C-2 and C-3. Place needle threads on top and to the left of presser foot before sewing.
7. Set stitch length and other machine adjustments. (See chart below)
8. Move the lock button release lever to the right.
9. Remove the blade cover and attach the sewing table. (see page 10)
10. Place the fabric under the needles and turn handwheel toward you two or three stitches in the fabric. Cut the excess threads and start sewing.

Note: All chain and cover stitches must be started with fabric under the needle.

TRIPLE COVER STITCH

NEEDLES C-1, C-2 and C-3	LENGTH 2,5 - 4,0	Set Needle Tension Dial to: 4-6	Set Chain Looper Tension Dial to: Cover Stitch
-----------------------------	---------------------	---------------------------------------	--

Triple Cover Stitch - 6mm - continued

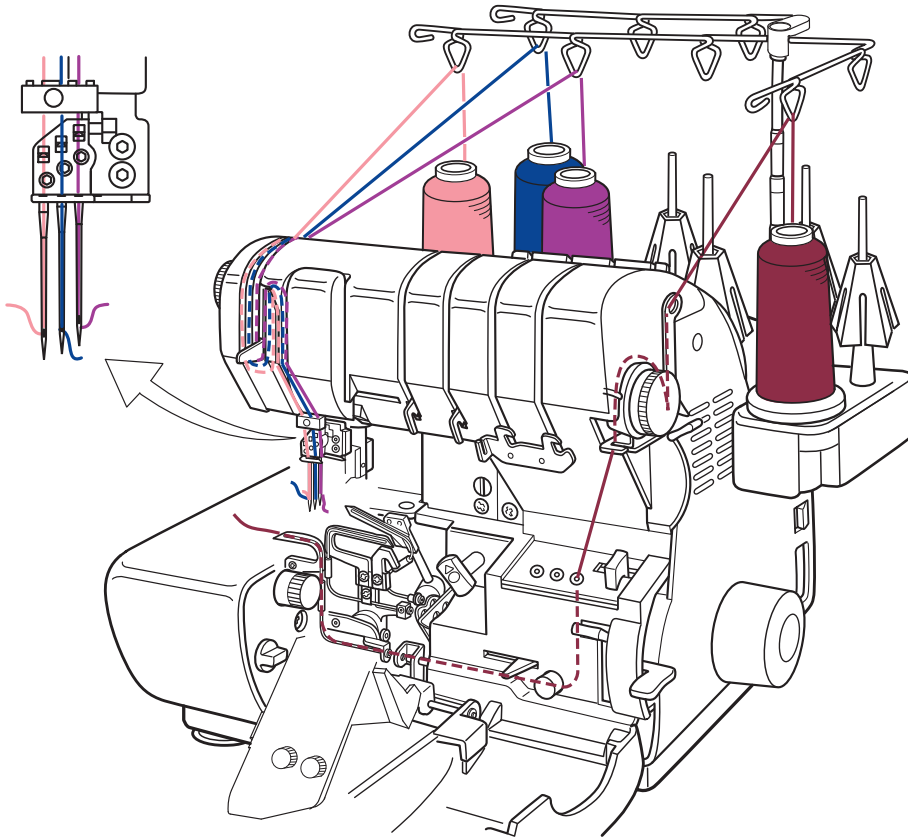

*Tension Adjustment

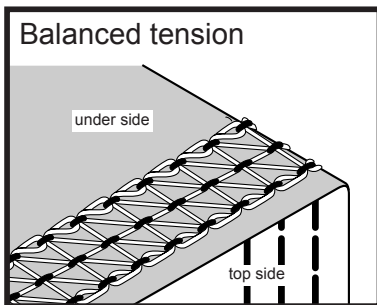

Balanced tension -

Triple Cover stitch has correct tension when the needle thread sew three rows of straight stitching on the top side and the chain looper forms a zig zag on the underside of the fabric.

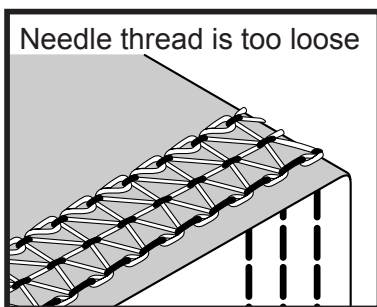

Needle thread is too loose -

Turn the chain/cover needle thread tension dial to a higher number. Or turn the chain looper tension dial away from the wide dash at the words "Cover Stitch", but, staying within the solid gold line. This will tighten the chain looper thread on the under side of the stitch.

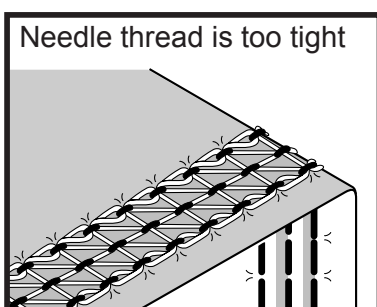

Needle thread is too tight -

For a looser tension turn the chain / cover needle thread tension dial to a lower number. Make sure that the chain looper tension dial is set at the solid dash at the words "Cover Stitch".

4-Thread Safety Stitch

The 4-thread safety stitch is perfect for all types of woven fabrics ranging from fine to heavy weight fabrics. This stitch is designed to seam and overlock the edge in one step, thus creating a garment industry standard safety stitch. As well as woven fabrics, the 4-thread safety stitch is for stabilizing knits, sweater knits and long seams on woven fabrics.

4-thread safety stitch is a combined stitch of a 2-thread overlock using subsidiary looper on the upper looper and a 2-thread chain stitch. The 4-thread safety stitch itself can be 3 different seam widths, depending on the chain/cover stitch needle position.

The varied widths can then work with different types of fabrics.

For 4-thread Safety Stitch:

1. Use standard blade cover.
2. Thread the upper, lower and chain loopers.
3. Thread one chain needle and the O-1 overlock needle (see diagram).
4. Engage the subsidiary looper in the upper looper.
5. Engage the blade to cut the fabric. Set stitch width dial at 7,5.
6. Select A on the Stitch Selector.

* See chart for settings of each size of 4-thread safety stitch.

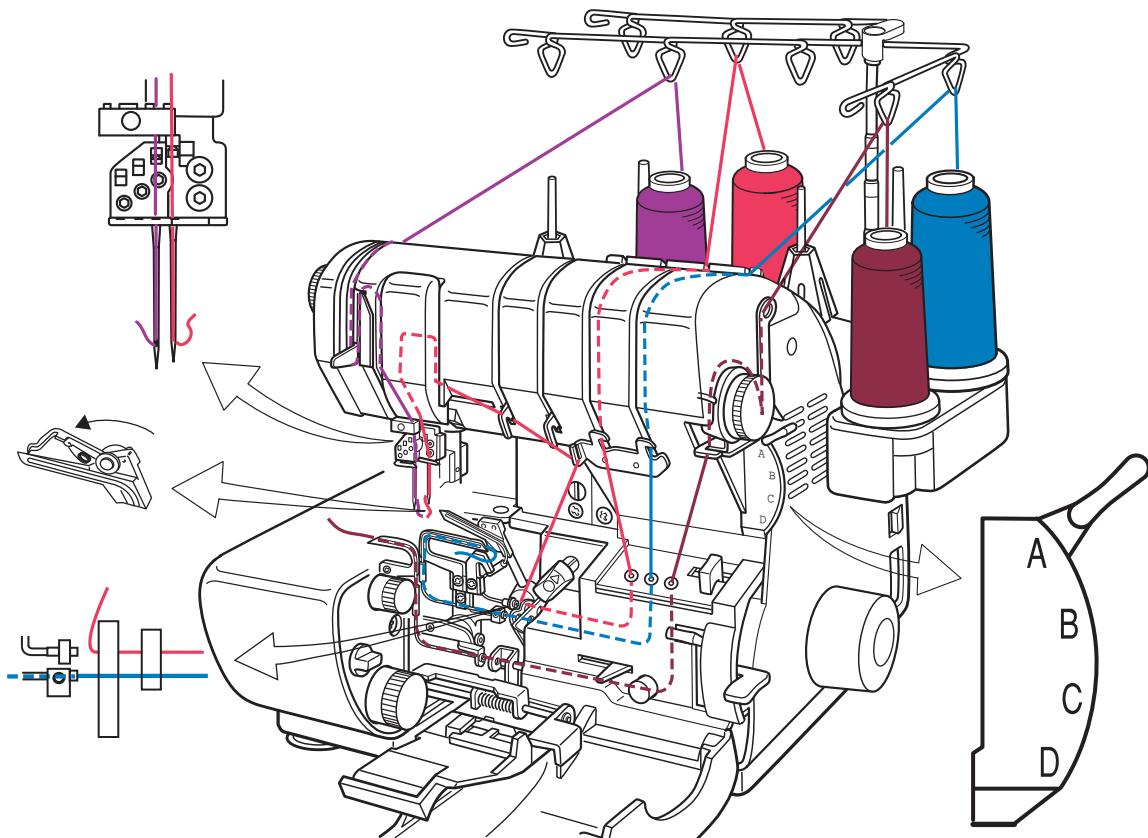

4-Thread Safety Stitch - continued

4-Thread Safety Stitch:
2-Thread Chain w/2-Thread Wide Overlock

16mm (5/8 inch)

13mm (1/2 inch)

10mm (3/8inch)

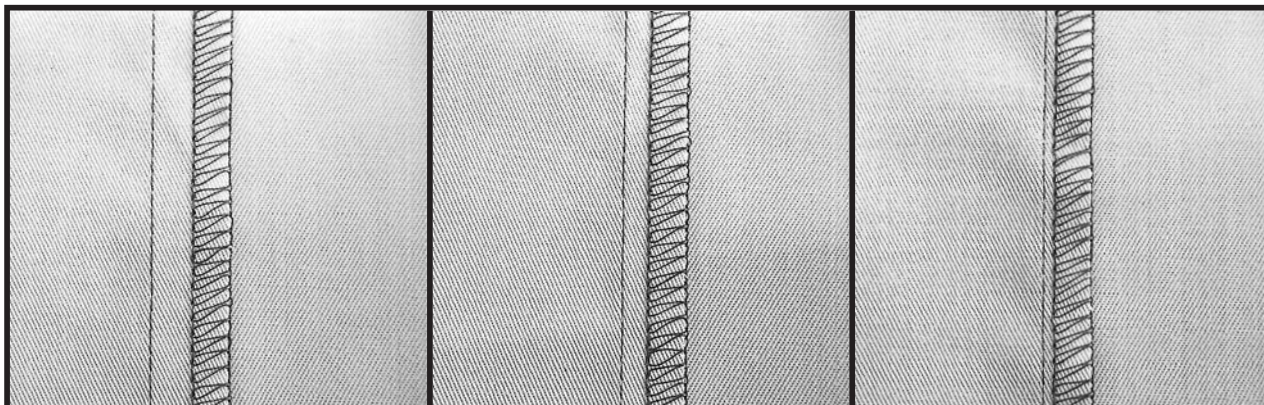

Size	Needle	Looper	Stitch Length	Stitch Width	Stitch Selector	Chain Needle Tension Dial	Chain Looper Tension Dial
16mm (5/8 inch)	C-1, O-1	C,L, Sub Looper	2,5-4,0	7,5	A	5	Chain Stitch
13mm (1/2 inch)	C-2, O-1	C,L, Sub Looper	2,5-4,0	7,5	A	5	Chain Stitch
10mm (3/8inch)	C-3, O-1	C,L, Sub Looper	2,5-4,0	7,5	A	5	Chain Stitch

Note: Stitch length, stitch width and chain needle tension settings may vary with different types of thread.

5-Thread Safety Stitch

The 5-thread safety stitch is perfect for all types of woven fabrics ranging from fine to heavy weight. This stitch is designed to seam and overlock the edge in one step, thus creating a garment industry standard stitch. As well as woven fabrics, the 5-thread safety stitch is for stabilizing knits, sweater knits and long seams on woven fabrics.

The 5-thread safety stitch is a combined stitch of a 3-thread overlock and 2-thread chain stitch. The 5-thread safety stitch itself can be up to 3 different seam widths, depending on the chain/cover stitch needle position. The varied widths can then work with different types of fabrics.

For 5-Thread Safety Stitch:

1. Use standard blade cover.
2. Thread the upper, lower and chain loopers.
3. Thread one chain needle and O-1 overlock needle. (See diagram).
4. Engage the blade to cut the fabric. Set stitch width dial at 7,5.
5. Select A on the Stitch Selector.

* See chart on next page for settings of each size of 5-thread safety stitch.

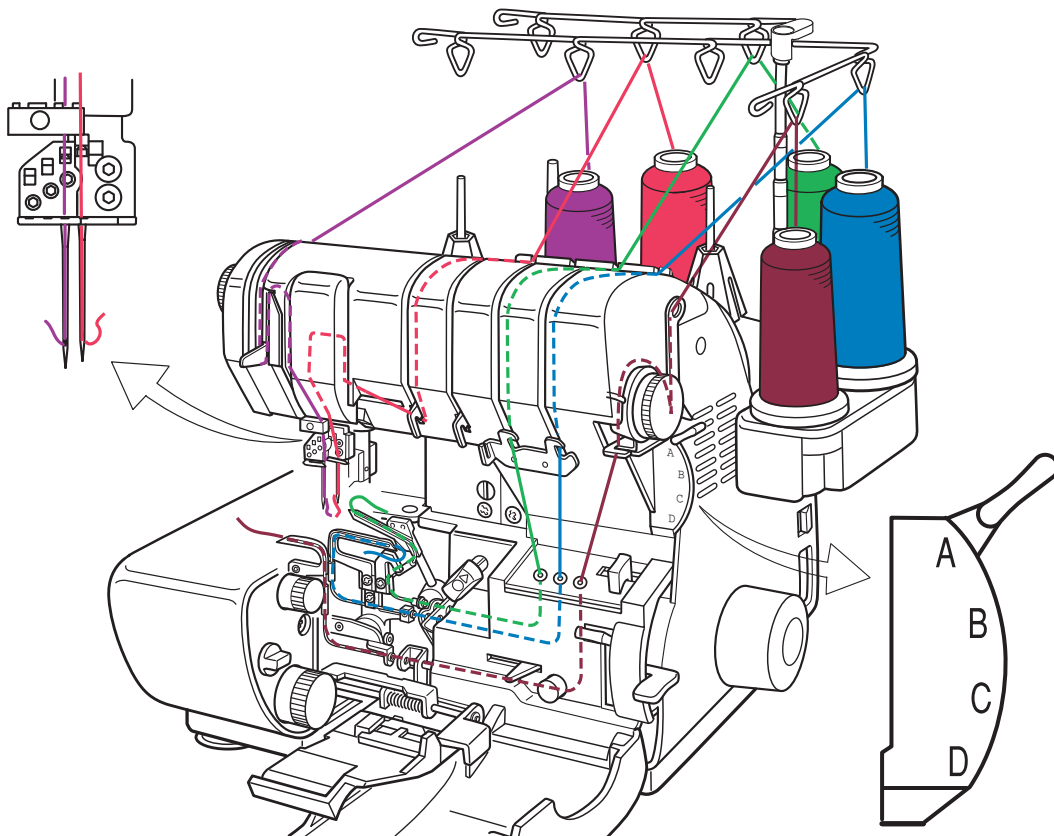

5-Thread Safety Stitch - continued

5-Thread Safety Stitch:
2-Thread Chain w/3-Thread wide Overlock

16mm (5/8 inch)

13mm (1/2 inch)

10mm (3/8inch)

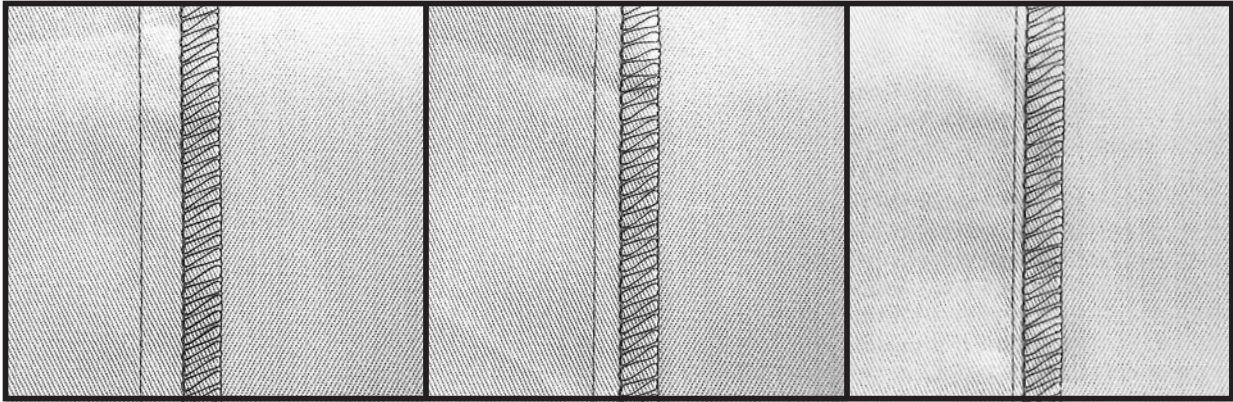

Size	Needle	Looper	Stitch Length	Stitch Width	Stitch Selector	Chain Needle Tension Dial	Chain Looper Tension Dial
16mm (5/8 inch)	C-1, O-1	U,L,C	2,5-3,5	7,5	A	5	Chain Stitch
13mm (1/2 inch)	C-2, O-1	U,L,C	2,5-3,5	7,5	A	5	Chain Stitch
10mm (3/8inch)	C-3, O-1	U,L,C	2,5-3,5	7,5	A	5	Chain Stitch

***Note:** Stitch length, stitch width and chain needle tension settings may vary with different types of thread.

8-Thread Stitch

8-Thread Stitch is a combined stitch of 4-thread overlock and 4-thread triple cover stitch. The 8-thread stitch is perfect for garment construction on heavy weight woven fabrics and used as a decorative topstitching with decorative overlock edge finish. The stitch is very durable as well as being a decorative stitch. The stitch width is 5/8 inch (16,0mm) wide.

For the 8-Thread Stitch:

1. Use standard blade cover.
2. Thread upper, lower, and chain loopers
3. Thread C-1, C-2, C-3, O-1, and O-2 needle positions
4. Engage the blade to cut the fabric.
5. Select A on the Stitch Selector.

The stitch selection charts in the back of the manual have other combination of stitches such as:

- 7-Thread - wide (Triple Cover Stitch with 3-Thread Overlock Wide)
- 7-Thread - narrow (Triple Cover Stitch with 3-Thread Overlock Narrow)
- 6-Thread - wide (Wide Cover Stitch with 3-Thread Overlock Wide)
- 6-Thread - narrow (Narrow Cover Stitch with 3-Thread Overlock Narrow)

All these stitch combinations work in the same manner as the 8-Thread Stitch. See next page for pictures of the various stitch combinations.

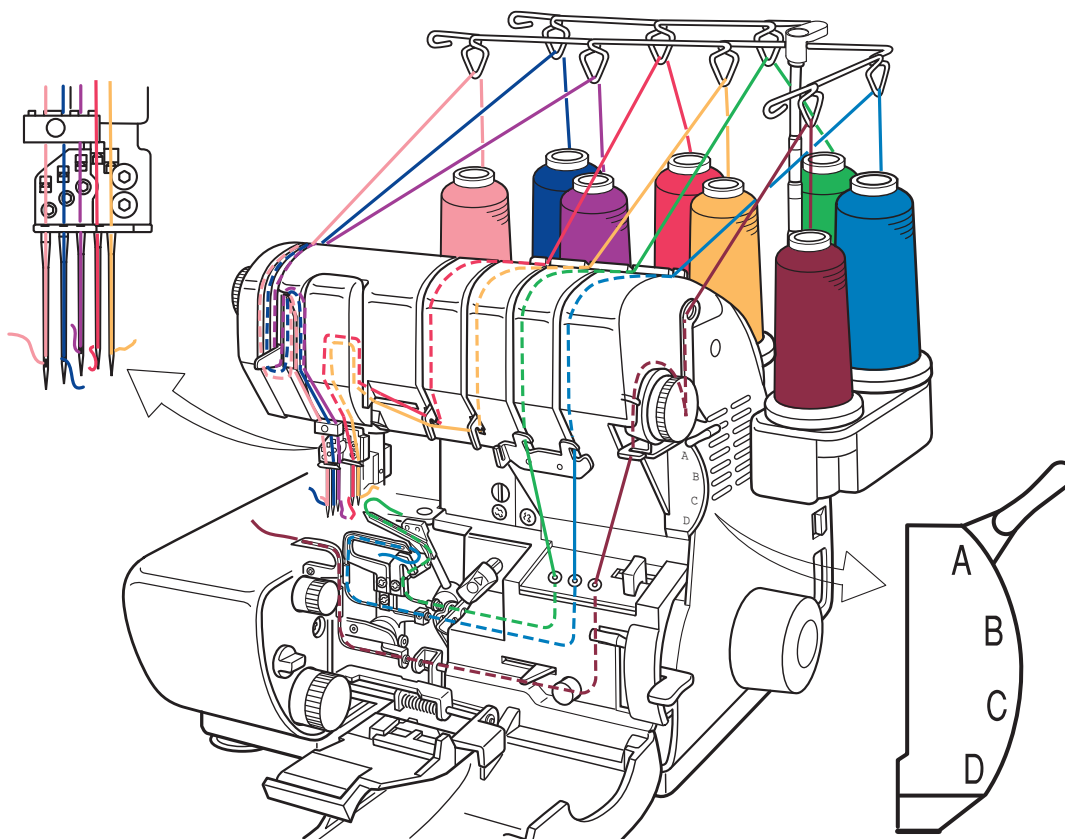

8-Thread Stitch - continued

Variations of Stitches

8-Thread Stitch
Triple Cover Stitch
w/ 4-Thread Overlock

7-Thread - wide
Triple Cover Stitch
w/3-Thread Overlock Wide

7-Thread - narrow
Triple Cover Stitch
w/3-Thread Overlock Narrow

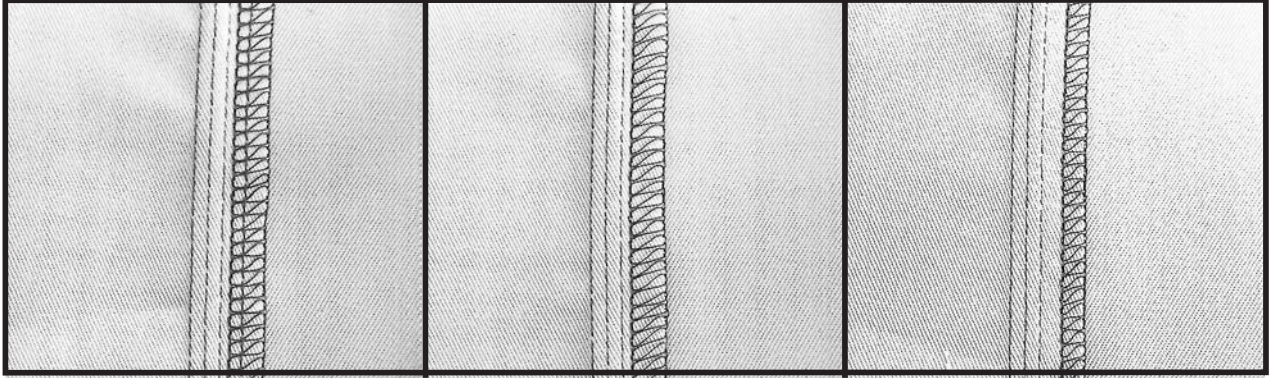

6-Thread - wide
Wide Cover Stitch
w/3-Thread Overlock Wide

6-Thread - narrow
Narrow Cover Stitch
w/3-Thread Overlock Narrow

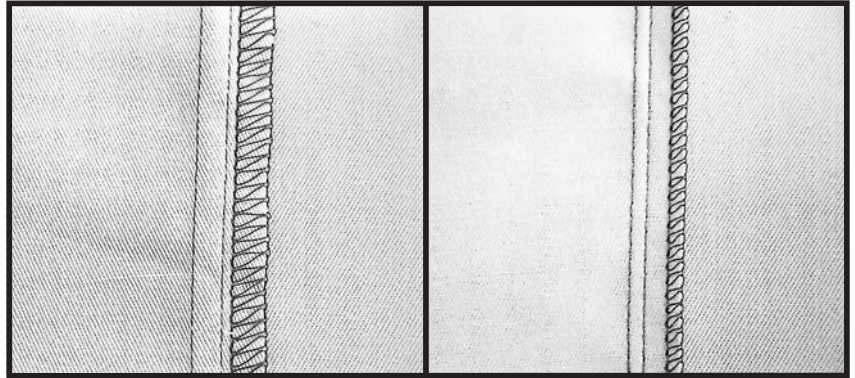

Expressive Stitches: Chain/Cover Stitches combined with Overlock Stitches

With the great features of Overlock Stitching and Chain/Cover Stitching on the evolve, many different stitches branch off from the basic "Express" stitches. The following combinations can let you "Express" your creativity as never before.

Use the "Stitch Selection Chart" at the back of the manual for threading your evolve with the different combinations.

The most common used combinations are the:

8-Thread Stitch - 4-Thread Overlock & Triple Cover Stitch

5-Thread Safety Stitch - 3-Thread Overlock & Chain Stitch C-3 needle position

4-Thread Safety Stitch - 2-Thread Overlock & Chain Stitch C-3 needle position

"Expressive" Combinations:

4-Thread Overlock & Chain C-3 needle position

4-Thread Overlock & Chain C-2 needle position

4-Thread Overlock & Chain C-1 needle position

4-Thread Overlock & Right Narrow Cover Stitch

4-Thread Overlock & Left Narrow Cover Stitch

4-Thread Overlock & Wide Cover Stitch

4-Thread Overlock & Triple Cover Stitch

3-Thread Overlock Narrow & Chain C-3 needle position

3-Thread Overlock Narrow & Chain C-2 needle position

3-Thread Overlock Narrow & Chain C-1 needle position

3-Thread Overlock Narrow & Right Narrow Cover Stitch

3-Thread Overlock Narrow & Left Narrow Cover Stitch

3-Thread Overlock Narrow & Wide Cover Stitch

3-Thread Overlock Narrow & Triple Cover Stitch

3-Thread Overlock Wide & Chain C-3 needle position

3-Thread Overlock Wide & Chain C-2 needle position

3-Thread Overlock Wide & Chain C-1 needle position

3-Thread Overlock Wide & Right Narrow Cover Stitch

3-Thread Overlock Wide & Left Narrow Cover Stitch

3-Thread Overlock Wide & Wide Cover Stitch

3-Thread Overlock Wide & Triple Cover Stitch

Expressive Stitches: Chain/Cover Stitches combined with Overlock Stitches

3-Thread Flatlock Narrow & Chain C-3 needle position
3-Thread Flatlock Narrow & Chain C-2 needle position
3-Thread Flatlock Narrow & Chain C-1 needle position
3-Thread Flatlock Narrow & Right Narrow Cover Stitch
3-Thread Flatlock Narrow & Left Narrow Cover Stitch
3-Thread Flatlock Narrow & Wide Cover Stitch
3-Thread Flatlock Narrow & Triple Cover Stitch

3-Thread Rolled Hem & Chain C-3 needle position
3-Thread Rolled Hem & Chain C-2 needle position
3-Thread Rolled Hem & Chain C-1 needle position
3-Thread Rolled Hem & Right Narrow Cover Stitch
3-Thread Rolled Hem & Left Narrow Cover Stitch
3-Thread Rolled Hem & Wide Cover Stitch
3-Thread Rolled Hem & Triple Cover Stitch

2-Thread Overlock Narrow & Chain C-3 needle position
2-Thread Overlock Narrow & Chain C-2 needle position
2-Thread Overlock Narrow & Chain C-1 needle position
2-Thread Overlock Narrow & Right Narrow Cover Stitch
2-Thread Overlock Narrow & Left Narrow Cover Stitch
2-Thread Overlock Narrow & Wide Cover Stitch
2-Thread Overlock Narrow & Triple Cover Stitch

2-Thread Overlock Wide & Chain C-3 needle position
2-Thread Overlock Wide & Chain C-2 needle position
2-Thread Overlock Wide & Chain C-1 needle position
2-Thread Overlock Wide & Right Narrow Cover Stitch
2-Thread Overlock Wide & Left Narrow Cover Stitch
2-Thread Overlock Wide & Wide Cover Stitch
2-Thread Overlock Wide & Triple Cover Stitch

Turning Corners - Chain Stitch

Sew to the point in fabric where you want to turn a corner. Stop the machine. Turn the handwheel toward you (counter clockwise) by hand, making sure the needle is going down in the fabric. Slowly start to raise the needle OUT OF FABRIC. Stop when you see the eye of the needle. (The point of the needle will still be in the fabric.) Raise the presser foot (fig A), and slowly pivot the fabric (fig B). Lower the presser foot and continue to sew (fig C).

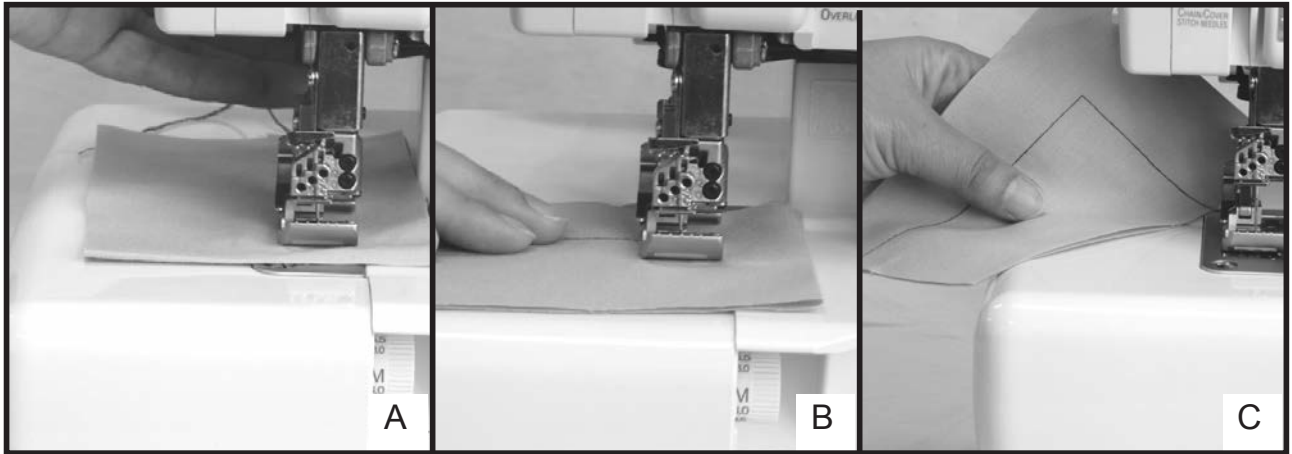

Turning Corners - Cover Stitch

Sew to the point in fabric where you want to turn a corner. Stop the machine. Turn the handwheel toward you (counter clockwise) until the needles are down in the fabric. Turn the handwheel away from you (clockwise) until the needles are in the highest position and the needles are out of the fabric. Raise the presser foot (fig A) and slowly pivot the fabric. Align the needles with the stitching on the fabric (fig B) and lower the presser foot. Continue to sew. (fig C)

To keep the stitch from unraveling at the corner(s), use a hand needle and thread to complete the corner on the top of the fabric and catch the chain looper thread on the underside.

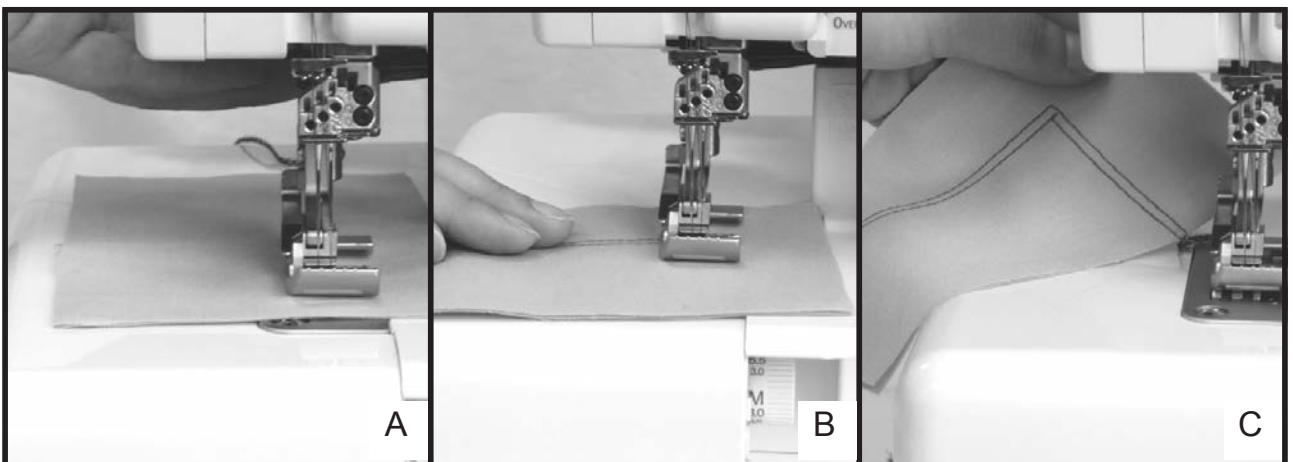

Turning Outside Corner - Overlock

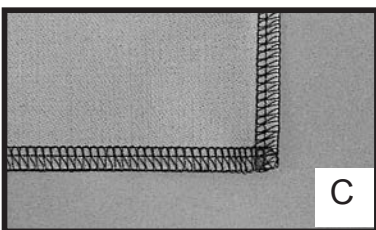
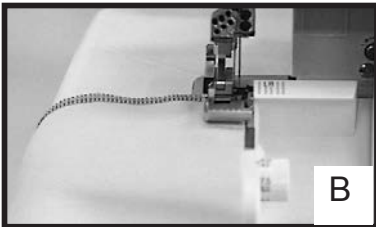
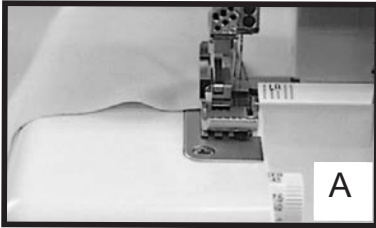

1. Stitch along one edge until you reach the corner. Take one stitch off the edge of the fabric (fig. A). (As you approach the edge, you may want to stop and manually turn the handwheel towards you.)
2. Raise the needle(s) to the highest position.
3. Clear the stitch fingers, and rotate the fabric to reposition the needle at the previous row of stitching (fig. B). Gently pull up on all threads to remove slack and resume stitching (fig. C).

Note: A loose thread loop at the corner is caused by too much slack in the needle thread when clearing the stitch fingers. Try again, turning corners takes a little practice!

Turning Inside Corner - Overlock

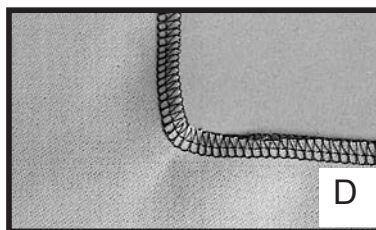
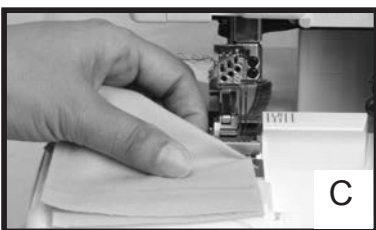
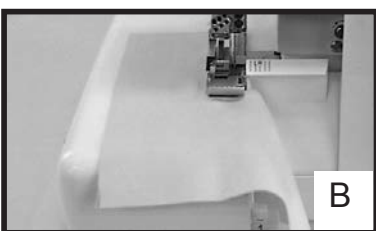
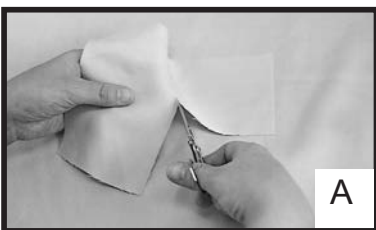

1. Reinforce loosely woven fabrics at the corner with stay stitching on the conventional sewing machine. Clip to the corner (fig. A).
2. Align the fabric edge with the blade, and stitch until the blade reaches the corner, not the needles. Don't cut into the corner (fig. B).
3. Lower the needle(s) to anchor the fabric.
4. Raise the presser foot and straighten out the fabric, forming a pleat at the corner (fig. C).
5. Be sure the marked stitching line is straight, then continue serging the remaining edge. When done correctly, the pleat will disappear after stitching (fig. D).

Flat Hemming - Cover Stitch

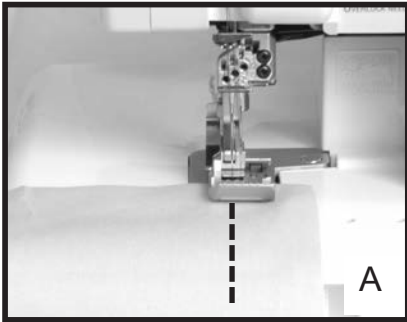

1. Leave one seam on the garment open.
2. Measure, turn up and press hem on garment.
3. On right side of garment mark hem allowance with marking pen.
4. Place garment right side up under the presser foot, aligning the marked hem with the needles. Make sure both needles are positioned on the raw edge of the hem (fig A).
5. Sew hem.
6. Sew seam on garment.

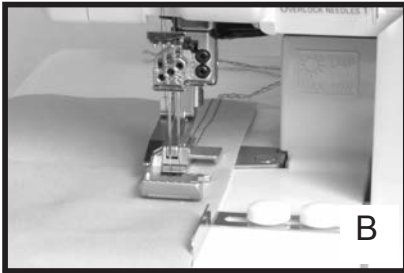

Note: Optional guide or attachments will help with hemming (fig.B). Ask your Baby Lock retailer.

Hemming in the Round - Cover Stitch

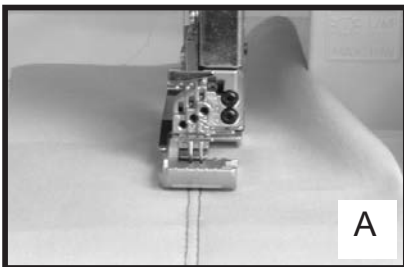

1. Sew all seams on the garment.
2. Measure, turn up and press the hem on garment.
3. Stitch around the hem, overlapping the hem approximately 1/2 inch (13mm). (fig.A)
4. Turn the handwheel towards you until the needles are in the lowest position in the fabric.
5. Carefully reverse the handwheel until the needles are in the highest position.
6. Raise the presser foot to release the tension.
7. Carefully and firmly pull fabric and threads to the left. Cut threads.
8. Pull threads to the back of fabric and tie off (fig.B).
9. Use a seam sealant to secure the threads at the tie off.

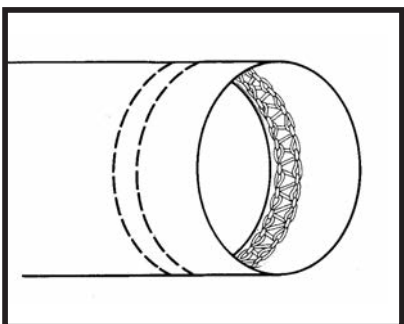
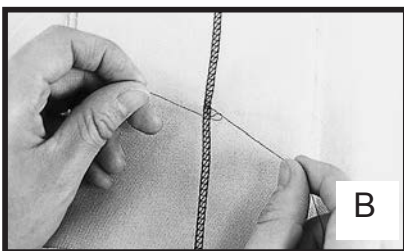

Blind Hemming - Overlock



Your Baby Lock evolve can create a sturdy, nearly invisible blindhem.

1. Set the machine for 2-Thread Overlock with the O-2 needle threaded. Set the stitch width at 5,0 and the stitch length at 4,0 in the standard range.
2. Fold up the hemline and press it in place. Then fold the hem allowance back against the fabric right side to create a fold about 1/4 " from the top edge of the hem as shown (fig. A).
3. Align the fold under the presser foot and stitch, allowing the needle to catch only a thread or two of the soft fold: the blade will trim the top edge of the hem and the loopers will overcast the edge for a clean finish (fig. B).
4. Open the fold and press flat (fig. C).

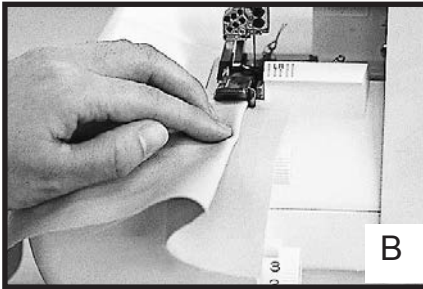

Note: An optional blindhem foot for consistent guiding is available through your Baby Lock retailer (fig. D).

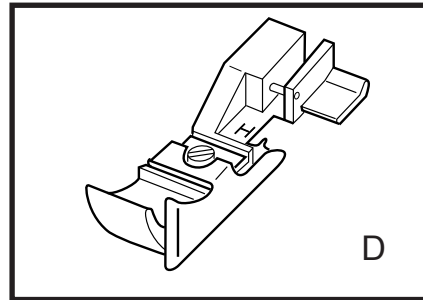
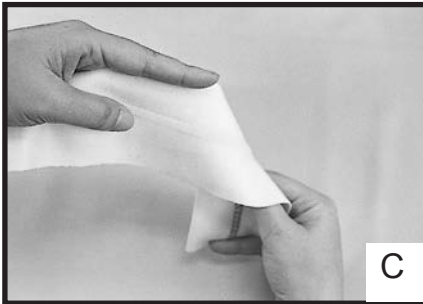

Sewing Curves - Overlock

To sew around inside or outside curves, guide the fabric into the blade, not the needle. Remember, cutting takes place before the fabric reaches the needle. Because the long serger presser foot holds the fabric more securely, you may need to raise and lower the presser foot several times to maneuver around very tight curves.

Inserting Tapes - Overlock

The slot in the standard presser foot is designed to guide stabilizing tape, narrow elastic or decorative ribbon into the stitching. Insert tape or elastic into the slot and under the back of the foot (fig. A). Adjust the stitch width to match the tape width. Place the fabric under the foot and stitch (fig. B).

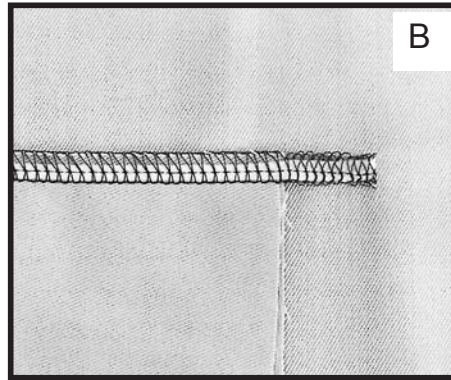
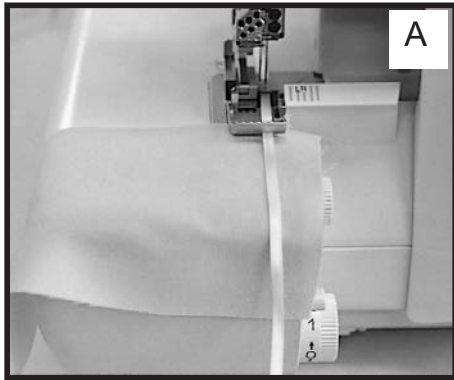

Inserting Tapes - Cover Stitch

The slot on the standard foot can be used with the narrow, wide, or triple cover stitches. Decorative tape, ribbon, or elastic can be inserted into the slot and sewn with the cover stitch (fig. A). Insert the tape, ribbon or elastic into the slot and down under the foot to the needles. (Remember, that the cover stitch must be started in the fabric). When using the sewing table, the decorative tape, ribbon, or elastic can be placed anywhere on the fabric (fig. B).

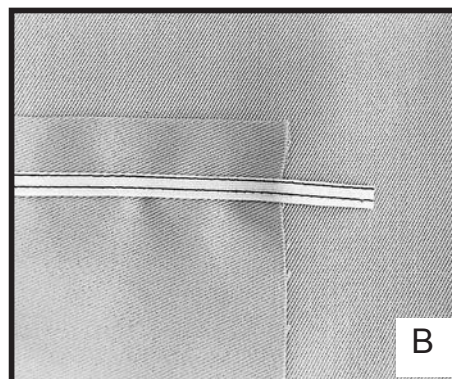
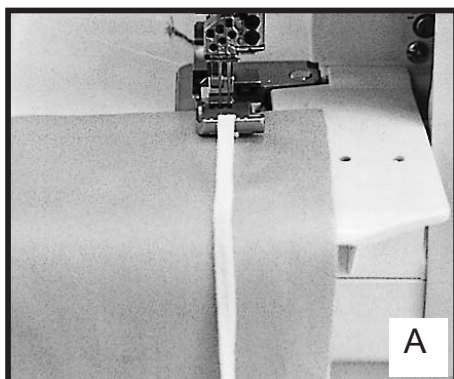

Flatlock "Decorative" - Overlock

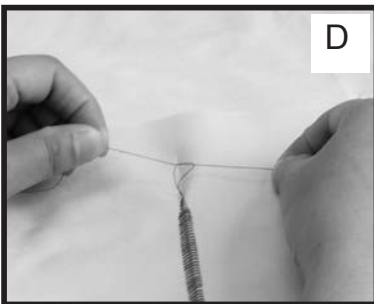
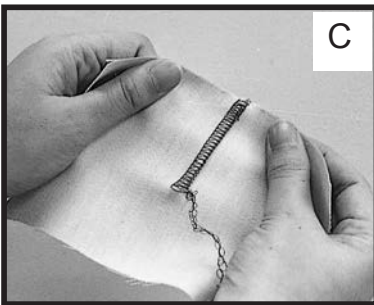
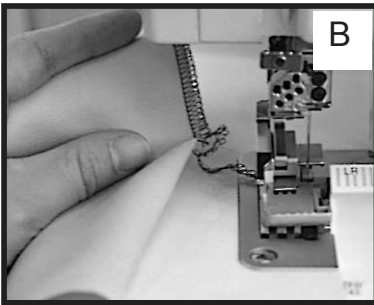
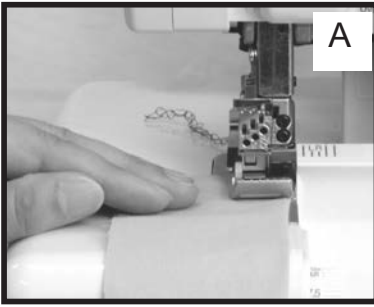

The flatlock stitch need not be limited at seamlines. When sewn on a fold, flatlocking can create attractive decorative effects within the body of a garment or project. Either follow placement lines on your pattern or design your own special effects by stitching the fabric before laying out pattern pieces.

1. Set the machine for 2-thread flatlock - wide. (See page 36)
2. Turn the cutting blade lock switch clockwise to disengage the upper cutting blade.
3. Set the stitch length to desired setting.
4. Fold the fabric (right side or wrong side out, depending on the loop or ladder stitch you want to show) along stitch placement lines.
5. Position the fabric under the presser foot, aligning the fold of the fabric 1/8 inch (3,5mm) to the left of the upper cutting blade (fig A). (See note).
6. Stitch to the desired ending point.
7. Clear the stitch fingers and chain off the fabric (fig B).
8. Clip threads, leaving a 3-4 inch (7,5-10cm) chain.
9. Gently pull the fabric to flatten the stitches (fig C).
10. Separate the chain threads and thread them through a needle and pull them to the fabric back side. If necessary, tie a knot to secure the threads (fig D).

Note: If the fabric does not pull completely flat under the stitches, guide the fabric fold to the left so that the loops hang slightly off the fold as they are being stitched.

Securing Ends - Overlock

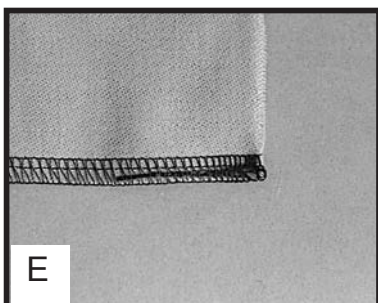
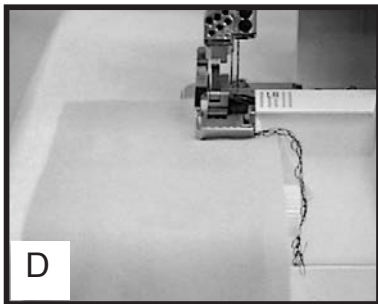
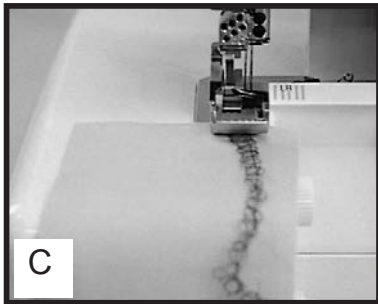
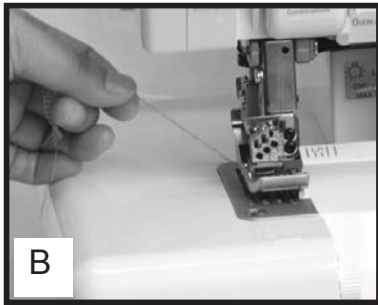
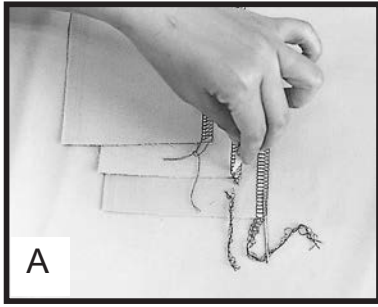

The serger stitch will not unravel readily, and in most cases serged seams are secured by an intersecting seam.

If that's not the case, these are several options for securing seam (fig. A).

1. Leave a 3 inch (7,5cm) chain, separate the threads and tie a knot.
2. Apply a dot of seam sealant on the thread chain at the fabric edge. Allow to dry and cut off the excess thread chain.
3. Leave a 3-4 inch (7,5-10cm) thread chain and use a large-eye tapestry needle or double-eye needle to weave the chain back into the stitching.
4. Lock the beginning or end of a seam by serging over the previous stitches.

To lock the beginning of the seam:

1. Manually turn the handwheel toward you taking 2-3 stitches into the fabric. Leave the needle(s) in the lowest position to anchor the fabric.
2. Raise the presser foot.
3. Smooth out the thread chain with your fingers (fig. B). Then bring the chain around and under the foot, so that it aligns with the edge of the fabric (fig. C).
4. Lower the foot and continue sewing, catching the thread chain in the stitches for about 1inch (2,5cm). Let the blades cut off any remaining thread chain (fig.D-E).

Securing Ends - Overlock cont.

To lock the end of the seam:

1. Take one stitch off the end of the seam (fig. A).
2. Raise the presser foot and bring the needle(s) to the highest position. Pull back gently on the fabric to clear the stitch fingers.
3. Turn the fabric over, end to end (fig. B), and reposition it under the presser foot with the needle at the seam edge, aligned with the previous needle line (fig. C).
4. Lower presser foot and sew 5-6 stitches over the previous stitches, being careful not to cut them. You may want to flip the cutting blade lock switch clockwise to the lock position. Pivot the fabric and chain off (fig. D-E).

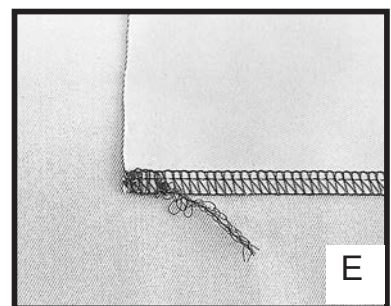
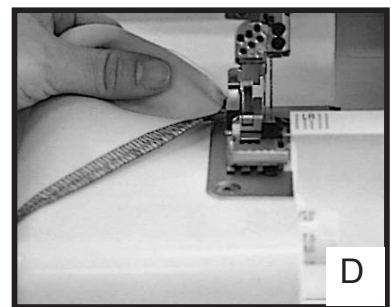
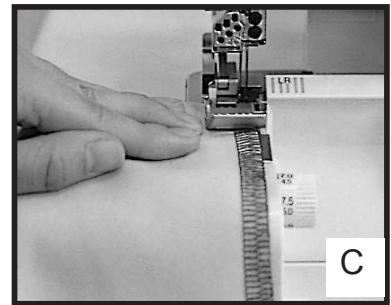
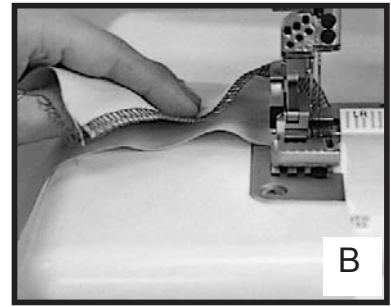
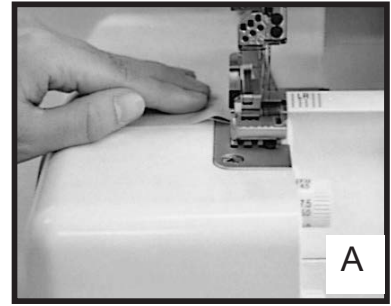

Securing Chain and Cover Stitching

The Chain Stitch and Cover Stitch can easily be removed. Trim the chain tail to edge of fabric at the "end" of the seam and pull on the chain looper thread on underside of the fabric. This will give you the opportunity to "Unsew" an incorrect seam very easily. To secure the chain stitch or cover stitch, at the end of the seam, bring the needle thread(s) to the back of the fabric and tug on the needle threads to secure them. The cover stitch needle threads may also be tied to prevent raveling of the stitch. Seam sealant can also be applied to the thread ends.

Because the chain stitch can be easily removed, the stitch can have a multitude of sewing functions.

- For dressmakers it can be used as a fitting seam. It can easily be removed to let out the seam quickly.
- Growth tucks in children's clothing.
- Sew in wide elastic in waistbands.

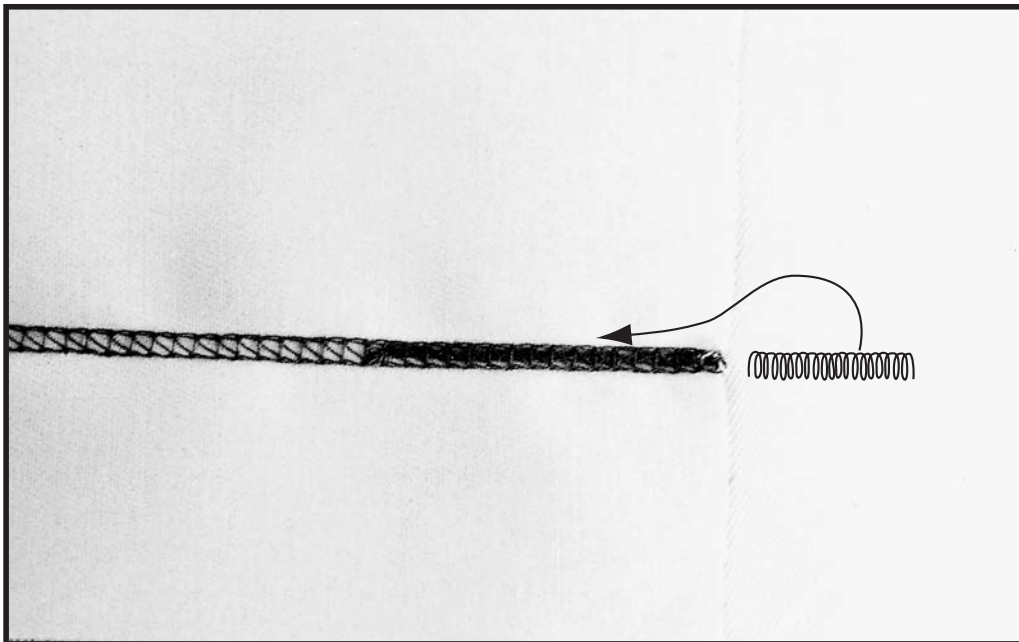

Using Specialty Threads

Beautiful stitches can be formed by serging with specialty threads, cords, and ribbons. These heavy or shiny threads can be used to enhance the appearance of a stitch, add strength and elasticity, or create special effects. It depends on the thread you choose for the chosen technique.

Some specialty threads work well through the needle and loopers, while others are too heavy to be threaded through the needle and are for looper use only.

Use the "Specialty Thread Guide Chart" on pages 72 & 73 as a guide for the specialty threads. Keep in mind that the quality of the thread may vary from one manufacturer to another. Make test samples before starting on the project.

Lightweight Threads

Lightweight threads such as rayon machine-embroidery thread, lingerie thread, can easily be threaded on the evolve. Very fine monofilament threads may need threading assistance of a "Threading Cradle" (pg. 71) or "Looper Threading Tool" (pg. 70)

Medium - weight Threads

Medium-weight threads, such as topstitching thread, Décor rayon, stretch nylon thread are too bulky to easily "jet-air" through the threading port and loopers. By using a "Threading Cradle" or "Looper Threading Tool", the heavier threads can be threaded easily in the evolve.

Heavy - weight Threads

Heavy-weight threads such as Pearl Crown Rayon, Décor 6, and Candlelight will need extra attention in the upper, lower, and chain loopers. Please follow the "Specialty Thread Guide Chart" on page 73 for special instructions concerning the use of these threads.

Bypassing the Threading Port

Heavy weight threads can be used through your regular looper thread paths. Specific techniques may require that the thread bypass the thread port for the thread pull to be loosened. Start with the machine threaded with regular serger thread.

1. Open front cover and raise the presser foot.
2. Just above the threading port, clip the looper thread to be replaced. Pull the thread out of the upper guides and remove the cone.
3. Place the specialty thread on the spool pin. Thread it into the upper guides and clip it a couple of inches beyond the base plate (fig. A).
4. With machine in the serging position, use the tweezers to pull the existing looper thread out of tube extending from the threading mechanism (fig. B). Leave the thread in the looper arm.
5. Tie the specialty thread onto the regular thread with an overhand knot (fig. C). Pull on the regular thread from the looper eye until the specialty thread comes through the looper eye (fig. D).
6. Place upper looper thread under the foot and to the left: clip lower looper thread at the base plate.

If the thread is heavy and the overhand knot (step #5) is too large for the looper tube, follow directions (#1 thru #6 on page 71) to make a thread cradle. Then:

1. Release machine lock button.
2. While holding the loose ends of the thread cradle with one hand, use the tweezers to pull the cradle loop out of the tube extending from the threading mechanism with the other hand.
3. Insert 2 inch(5cm) of your decorative thread into the cradle loop. Pull on the loose ends of the thread cradle from the looper eye until the specialty thread comes through the looper eye.

When bypassing the threading port, thread will be visible from the guide to the looper tube (fig. E). Close the blade cover and front cover before continuing to sew.

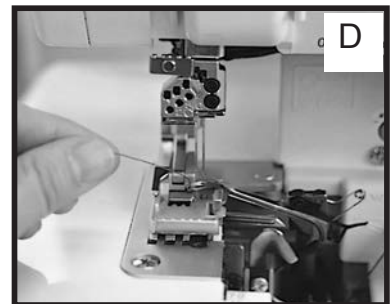
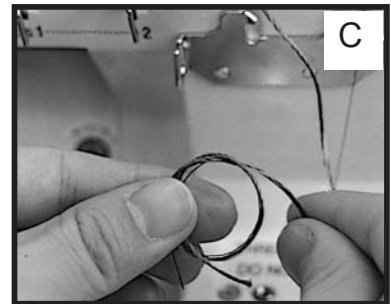
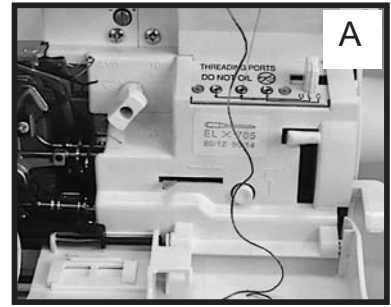

Looper Threading Tool

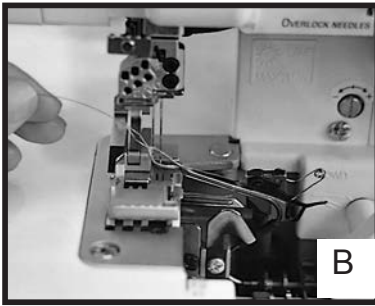
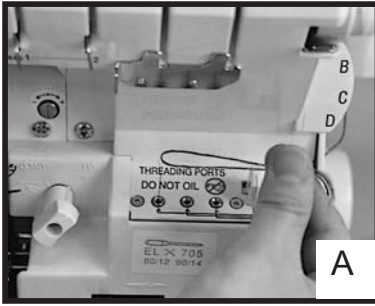

1. Open the front cover and raise the presser foot.
2. At the threading port, cut the looper thread that is to be replaced. Remove thread from under the foot and the upper thread guides. Replace cone of thread with specialty thread.
3. With machine in locked position set the looper threading port to U, L, or C according to the looper that is being threaded.
4. Thread specialty thread into the upper thread guides, leaving an 18 inch (40cm) tail above the threading port.
5. Place the straight end of the looper threading tool into the threading port. Push the looper threading tool until the end comes out of the looper eye. For the chain looper, open side door of machine to see threading tool come out of the eye of chain looper.
6. Insert the specialty thread tail into the looper threading tool eye (fig.A). Pull the straight end of the looper threading tool through the looper eye bringing the specialty thread with it. (fig.B)
7. Run upper looper thread under the foot and to the left, cut lower looper thread to 4 inches (10cm) and leave it hanging loose. Cut chain looper thread 4 inches (10cm) and place in tray. Close side door of machine.

Thread Cradle for Loopers

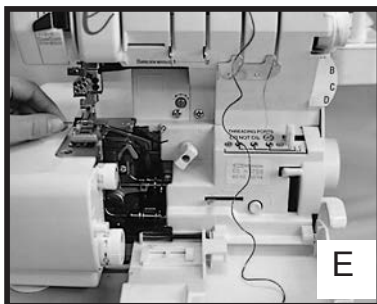
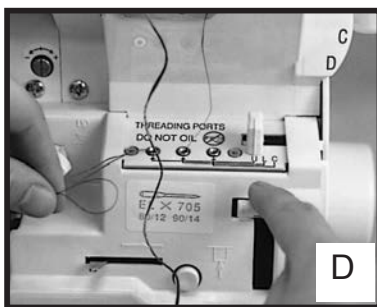
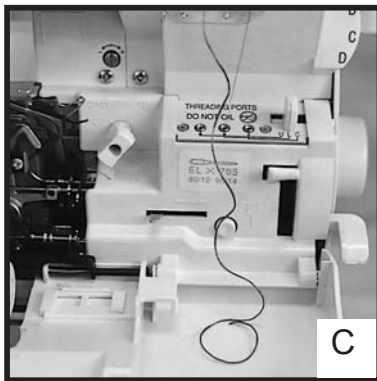
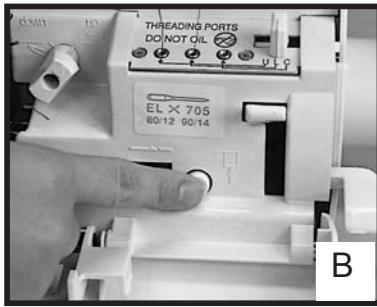
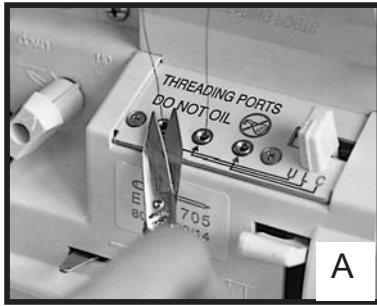

1. Open the front cover and raise the presser foot.
2. At the threading port, clip the looper thread that is to be replaced (fig.A). Remove thread from under the foot and the upper thread guides. Replace cone of thread with specialty thread.
3. With machine in locked position (fig.B) set the looper threading port to U, L, or C according to the looper that is being threaded.
4. Thread specialty thread into the upper thread guides, leaving an 18 inch (40cm) tail above the threading port. (fig.C)
5. Cut a 24 inch (55cm) strand of serger thread and fold in half to form a thread cradle. Insert the loose ends of the thread cradle into the port about 1 inch (2.5cm).
6. Holding the cradle loop with left hand, depress the threading lever with your right hand (fig.D) until the thread ends come out the looper eye. For chain looper, open side door of machine to make sure thread is in eye of chain looper.
7. Insert the specialty thread tail into the cradle loop (fig.E), pull the serger thread ends until the specialty thread comes through the looper eye (fig.F). Discard or set aside the thread cradle.
8. Run upper looper thread under the foot and to the left, cut lower looper thread to 4 inches (10cm) and leave it hanging loose. Cut chain looper thread 4 inches (10cm) and place in tray. Close side door of machine. (fig.G)

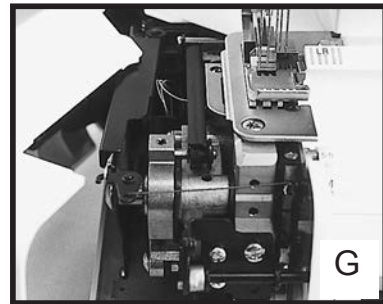
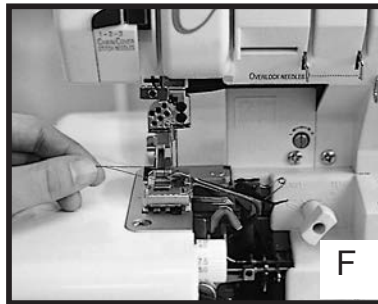

Specialty Thread Guide Chart

OVERLOCK STITCHES	Topstitching Buttonhole Twist (Medium Weight)	Wooly Nylon (Medium Weight)	Metallic Threads (Lightweight)
APPLICATION	Decorative Edging Decorative Flatlocking	Rolled Hem Soft seams on Lingerie and sportswear	Decorative Edging Decorative Topstitching
4-Thread Seams	Not recommended	Use in loopers only	For decorative exposed seams. Use in needles and loopers
4-Thread Edging	Use in loopers only	Use in loopers only	Use in needles and loopers
3-Thread Seams	Not recommended	Use in loopers only	For decorative exposed seams. Use in needles and loopers
3-Thread Edging	Use in loopers only	Use in loopers only	Use in needle and loopers
3-Thread Rolled Edging	Use in upper looper only	Use in upper looper only	Use in upper looper only Lengthen stitch length
2-Thread Flatlock (wide or narrow)	Not recommended	Use in lower looper only	Use in lower looper only
COMMENTS:	Sew at a slower speed when sewing with heav- ier threads		Sew at a slower speed when sewing with metallic threads.
CHAIN/COVER STITCHES	Topstitching Buttonhole Twist (Medium weight)	Wooly Nylon (Medium weight)	Metallic Threads (Light weight)
2-Thread Chain C-1,C-2 or C-3 Needle Position	In chain looper only	In chain looper only	In chain needle only
3-Thread Cover Stitch Left narrow Right narrow Wide	In chain looper only	In chain looper only	In needles only
4-Thread Triple Cover	In chain looper only	In chain looper only	In needles only
5-Thread Safety Stitch	Not recommended	In loopers only	Not recommended
6-Thread Stitch 7-Thread Stitch 8-Thread Stitch	In loopers only	In loopers only	Not recommended
COMMENTS:	Not recommended for needles. Use in looper(s) only.	Not recommended for needles	Sew at a slower speed when sewing with metallic threads.

Specialty Thread Guide Chart

OVERLOCK STITCHES	Clear Nylon Filament (lightweight) ※1	Lingerie Thread, Rayon or Polyester Machine-embroidery Thread (lightweight) ※2	Decorative Thread: Décor, Candlelight, Pearl Crown Rayon (heavy weight) ※3
APPLICATION	Techniques requiring thread invisibility.	Lingerie and lightweight fabrics, edging of fine fabric, fine rolled hem	Decorative edging Decorative flatlocking Decorative rolled hem Decorative chain/cover-stitching
4-Thread Seam	Not recommended	Lingerie thread for seams. Machine embroidery thread for exposed decorative seams	Not recommended
4-Thread Edging	Not recommended	Machine Embroidery Thread only	Use in looper(s) only
3-Thread Seams	Recommended for blind hemming	Lingerie thread only	Not recommended
3-Thread Edging	Not recommended	Machine Embroidery Thread only	Use in looper(s) only
3-Thread Rolled Edging	Lengthen Stitch length slightly	Use in needle and loopers	Use in looper(s) only
2-Thread Flatlock (wide or narrow)	Recommended for blind hemming.	Use in needle and lower looper	Use in lower looper only
COMMENTS:	Make sure to use soft, pliable monofilament thread. Sew at a slower speed when sewing with monofilament thread.	Use thread nets or sponge disks to keep thread from spilling off spool. Sew at a slower speed when sewing with decorative thread.	Candlelight thread: Bypass threading ports when threading loopers. Sew at a slower speed when sewing with decorative thread.
CHAIN/COVER STITCHES	※1	※2	※3
2-Thread Chain C-1, C-2 or C-3 Needle Position	Use in needle and chain looper	Use in needle and chain looper	Use in chain looper only
3-Thread Cover Stitch Left narrow Right narrow Wide	Use in needles and chain looper	Lingerie thread: Use in needles and chain looper. Machine embroidery thread: Use in needles only.	Use in chain looper only
4-Thread Triple Cover	Use in needles and chain looper	Lingerie thread: Use in needles and chain looper. Machine embroidery thread: Use in needles only.	Use in chain looper only
5-Thread Safety Stitch	Not recommended	Lingerie thread recommended only	Use in chain looper and lower looper only for a reverse decorative stitch.
6-Thread Stitch 7-Thread Stitch 8-Thread Stitch	Not recommended	Machine embroidery thread only	Use in chain looper and lower looper only for a reverse decorative stitch.
COMMENTS:	Make sure to use soft, pliable monofilament thread. Sew at a slower speed when sewing with monofilament thread.	Use thread nets or sponge disks to keep thread from spilling off spool. Sew at a slower speed when sewing with decorative thread.	Not recommended for needles

Troubleshooting

Before taking your machine in for service, check the following:

Machine fails to start:

1. Are electrical plugs properly connected?
2. Is the power switch on?
3. Check household circuit breaker or fuse.
4. Is the lock button release lever in the unlocked position?

Thread breaks:

1. Is the machine threaded correctly? Check each thread path carefully.
2. Is the correct needle inserted for the particular stitch? - C-1, C-2, C-3, O-1, or O-2?
3. Is the needle inserted correctly?
4. Is the needle bent and worn?
5. Are you using good quality thread?
6. Is the thread feeding off the cone/spool freely?
7. Is the needle size correct for the type of fabric being used?
8. Are the needles being used the correct Organ or Schmetz ELx705CF system?

Chain or Cover Stitching:

1. Are the tensions too tight on the chain/cover needles or the chain looper?
2. Is the stitch length too short?
3. Did you start the first stitch in the fabric?

Overlock stitching:

1. Is the stitch selector on the proper setting?
2. Is the upper looper positioning lever in the "UP" position?

Skipped Stitches:

1. Is the needle bent or worn?
2. Is the needle inserted correctly?
3. Is the serger threaded correctly?
4. Is the presser foot pressure right for the fabric?
5. Is the correct needle being used for the particular stitch?
6. Is the correct needle being used for the type of being sewn fabric?
7. Is the fabric being pulled from the rear of the machine while sewing?

Fabric will not feed in machine:

1. Is the machine lock button released?
2. Is the presser foot down?
3. Are the cutting blades sharp?
4. Are the cutting blades, presser foot, and feed dogs free of lint?
5. Are the cutting blades properly set and is the upper blade against the lower blade?
6. Is the presser foot pressure right for the fabric?
7. Is the stitch length set properly?
8. Is the needle plate secure on the machine?

Troubleshooting Continued

Stitch Unbalanced:

1. Is the serger threaded correctly?
2. Is the proper presser foot on the serger?
3. Is the correct needle inserted and threaded?

Chain or Cover Stitch unbalanced:

1. Is the thread in the tensions?
2. Are the tensions set correctly for the chain/cover needles?
3. Is the tension dial set correctly for the chain looper?
4. Is the chain looper threaded correctly?
5. Is the needle thread(s) in the correct tension disk?

Overlock Stitching unbalanced:

1. Is the stitch selector on the proper setting?
2. Is the thread well seated in the thread slots?
3. Is the looper thread fine-tuning screw positioned correctly?

Note: If you change the position of the looper thread fine-tuning screw and the stitch is unbalanced, return the screw to the standard position and recheck the stitch.

Looper threading difficulties:

1. Is the looper threader selector at the appropriate setting?
2. Is the thread end in the proper threading port?
3. Is at least 1 inch (2,5cm) of the thread end in the threading port?
4. Is there at least 18 inches (45cm) of loose thread beyond the thread guide above the threading port?
5. Is the upper looper positioning lever set at "UP" position for serging?
6. Is there a kink or twist in the 18 inch (45cm) of thread to restrict the flow into the threading port?
7. Is the thread caught to prevent going through the loopers?

Poor Cutting:

1. Are the cutting blade(s) dull?
2. Have you sewn over a straight pin?
3. Is the cutting blade in the locked position?
4. Have the cutting blades been improperly replaced?
5. Is the fabric being pulled from the rear of the machine while sewing?

Replacing Needles

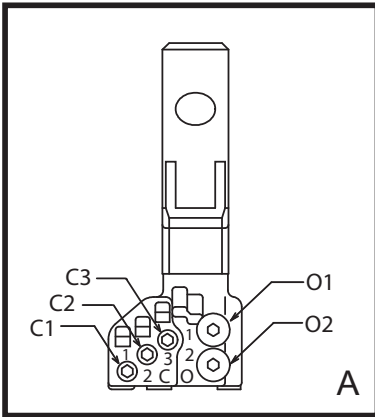

Needle Identification (fig. A)-

The chain/cover stitch needles are on the front portion of the needle clamp and are identified by C-1, C-2 and C-3.

C-1-Left chain/cover stitch needle can be used for chain stitch, left narrow cover stitch, wide cover stitch or triple cover stitch.

C-2-Center chain/cover stitch needle can be used for a chain stitch, left narrow cover stitch, right narrow cover stitch or triple cover stitch.

C-3-Right chain/cover stitch needle can be used for a chain stitch, right narrow cover stitch, wide cover stitch, or triple cover stitch.

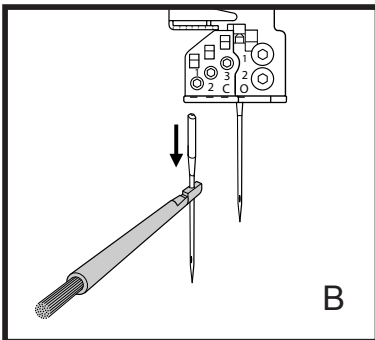

The overlock needles are on the back portion of the needle clamp and are identified by O-1 and O-2.

O-1-Left overlock needle can be used for wide overlock stitches.

O-2-Right overlock needle can be used for narrow overlock stitches and rolled or narrow hemming.

Note: Both overlock needles are used for 4-thread overlock stitching.

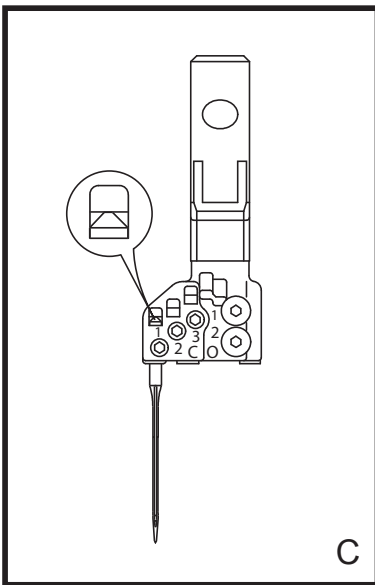

To replace a needle -

1. Raise the needle to the highest position by turning the hand-wheel toward you.
2. Using the allen screwdriver, loosen the needle screw for the needle to be changed. Screws are located by sequence as indicated above.

Note: To prevent the needle from falling into the needle plate, hold it with the needle insert tool as you loosen the screw (fig. B).

3. Use the needle insert tool or tweezers to insert the new needle with the flat side to the back.

Insert needle as far as it will go, check the needle viewing window (fig. C).

4. Tighten the needle clamp screw.

Note: If you do drop a needle down into the machine just pull out the needle-drop drawer at the bottom of your serger.

The needle will be on the drawer (fig. D).

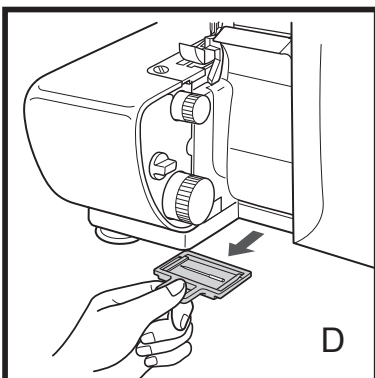

Replacing Cutting Blades

The fixed blade is made of a special long lasting steel and does not require frequent replacement. If necessary, contact your nearest retailer for replacement of the blade.

The upper moving blade is made of a softer steel material and will require replacement. A spare blade is provided with the machine for replacement if necessary. The spare blade is located on the thread spool stand accessory compartment.

If for some reason your machine does not cut or perform as it should be, please take your machine to your nearest Baby Lock retailer. It is possible that the result of poor cutting may indicate other problems.

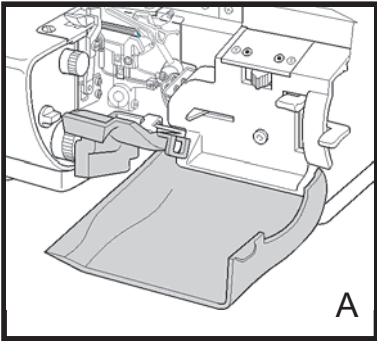

- TO REPLACE MOVING BLADE proceed as follow;
1. For safety reasons, unplug main power cord.
 2. Open front cover and cutting blade cover (fig. A):
 3. Remove screw and moving blade (fig. B).
 4. Insert new blade into blade slot.
 5. Insert screw and place moving blade to its highest position.
 6. Hold blade in place and tighten screw.
 7. Check and make sure that the top section of cutting blade is set below the fixed blade when moving blade is in its lowest position.
 8. Close cutting blade cover and front cover.

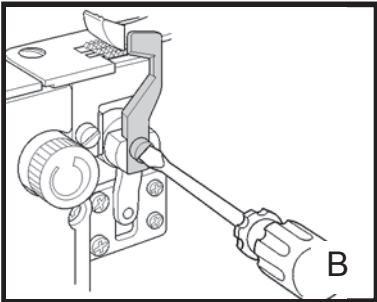

Replacing Light Bulb

1. For safety reasons, unplug main power cord prior of replacing light bulb.
2. Open front cover and cutting blade cover.
3. Remove light bulb and replace bulb with the same type rated (15watts/110volts or 15watts/240volts). See below draft for reference.

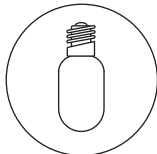
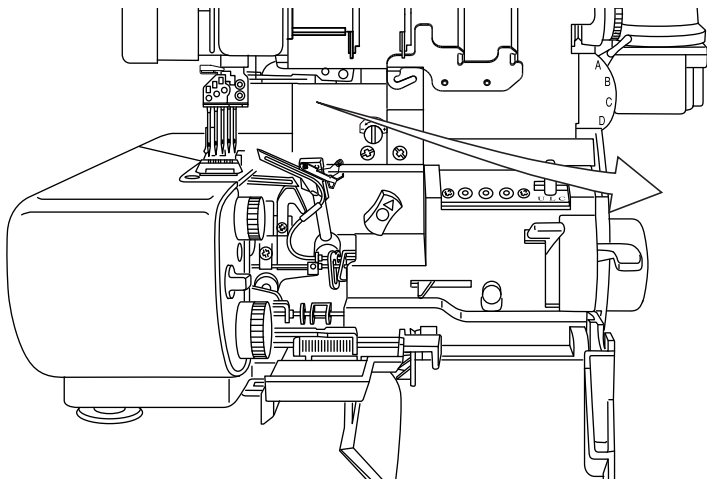

15W / 110V
(Screw Type)

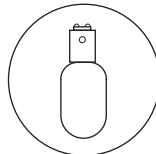

15W / 240V
(Bayonet Type)

Cleaning

Your Baby Lock will operate at best performance if it is kept clean at all times. The serger's cutting action creates much more lint than you will find on conventional sewing machine.

Your serger's major moving parts are well protected and do not need to be oiled.

However, we recommend to use the cleaning brush often during garment construction in order to keep lint off the blades, the needle bar, the feed dog mechanism and loopers. If machine needs to be oiled, check with your nearest Baby Lock retailer for use of high grade recommended sewing machine oil.

TO REMOVE NEEDLE PLATE PROCEED AS FOLLOW:

1. For safety reasons, unplug main power cord
2. Raise and remove presser foot.
3. Select stitch length dial to rolled hem setting.
4. Remove needles from needle clamp.
5. For easy access to the needle plate lock pin set screw, lower needle clamp to its lowest position. (fig. A).
6. Place allen screwdriver (1,5mm) into allen screw and loosen needle plate pin holder screw. (See fig. B for location of screw.)
7. Remove needle plate lock pin (fig B) and remove needle plate front screw. (See arrow in fig B)
8. Open left side cover of machine and remove needle plate.
9. Clean machine. (fig C)
10. Place needle plate onto machine and insert needle plate lock pin.
11. Tighten allen screw needle plate lock pin and check and make sure that top needle plate lock pin is flush with needle plate.
12. Place needle plate front screw and tighten screw.

Note: For better stitch performance, make sure needle C-1.and C-3 do not touch either side of needle plate hole.

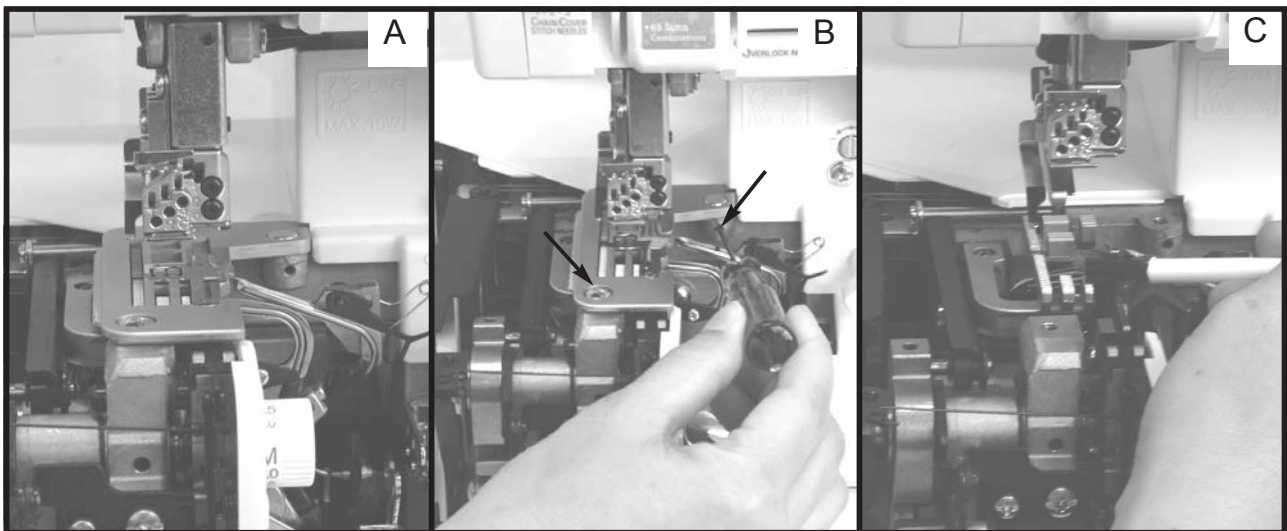

Technical Data

Stitch Types:

- Chain Stitch
- Left (C-1), Center (C-2), Right (C-3)

Cover Stitch

- Narrow Left
- Narrow Right
- Wide
- Triple

Overlock Stitch

- 4-Thread Overlock (narrow and wide)
- 3-Thread Overlock (narrow and wide)
- 3-Thread Flatlock
- 3-Thread Rolled Hem
- 2-Thread Overlock (narrow and wide)
- 2-Thread Flatlock (narrow and wide)

Combined Stitch

- 5-Thread Safety Stitch
- 6-Thread Stitch
- 7-Thread Stitch
- 8-Thread Stitch

Stitch Width:

Cover Stitch

- Triple Cover Stitch : 6,0mm
- Cover Stitch - Wide : 6,0mm
- Cover Stitch - Narrow: : 3,0mm

Overlock Stitch

- Standard 2/3/4-Thread Overlock with left needle : 5,5-7,5mm
- Standard 2/3-Thread Overlock with right needle : 3,0-5,0mm
- 3-Thread Rolled Hem with right needle : 1,5mm

Combined Stitch

- 5-Thread Safety Stitch: 6,5-16,0mm
- 6-Thread Ultra Stitch: 9,5-16,0mm
- 7-Thread Ultra Stitch: 12,5-16,0mm
- 8-Thread Ultra Stitch: 14,0-16,0mm

Stitch Length:

0,75 - 4,0mm

Differential Feed:

Gathering effect: N ~ 2

Stretching effect: N ~ 0,6

Presser Foot:

Snap on exclusive feet for evolve

Handwheel:

Rotate forward (counter clockwise)

Loopers:

3 Loopers: Upper(U), Lower(L), Chain(C)

Needle System:

Organ or Schmetz ELx705CF #80/12 - #90/14

Number of Needles:

5 total: 3 Chain/Cover Stitch, 2 Overlock

Sewing Speed:

Up to 1500 s.p.m.

Machine Weight:

8,3Kg

Light System:

15W/110V or 15W/240V

Chart for stitch selection settings for Chain/Cover and Combination stitches

Name of Stitch	Nb. Needles & ndle position	Looper(s) U - L - C	Stitch L/dial	Stitch W/dial	Stitch Selector	Ch. looper tension dial	Ch/Cov ndle tension dial	Diff. Feed	Finish seam Width	
8 Thread										
Triple Cover stitch with 4 thread overlock	C1 - C2 - C3 with	U - L - C	2,5 - 4,0	7,5	A	Cover Stitch	5,0 *	N	16 mm	
	O-1 / O-2	"	"	"	"	"	"	"	"	
7 Thread										
Triple Cover stitch with 3 thread overlock	C1-C2-C3-O1 (Wide)	U - L - C	2,5 - 4,0	7,5	A	Cover Stitch	5,0 *	N	16 mm	
	C1-C2-C3-O2 (Narrow)	U - L - C	2,5 - 4,0	5,5	B	Cover Stitch	5,0 *	N	16 mm	
Cover Stitch with 4 thread overlock	C1-C2-O1-O2	U - L - C	2,5 - 4,0	7,5	A	Cover Stitch	5,0 *	N	16 mm	
	C1-C3-O1-O2	"	"	"	"	"	"	"	16 mm	
	C2-C3-O1-O2	"	"	"	"	"	"	"	13 mm	
6 Thread										
Cover Stitch with 3 thread overlock O1 (wide) O2 (narrow)	C1-C2-O1	U - L - C	2,5 - 4,0	7,5	A	Cover Stitch	5,0 *	N	16 mm	
	C1-C3-O1	"	"	"	"	"	"	"	16 mm	
	C2-C3-O1	"	"	"	"	"	"	"	13 mm	
	C1-C2-O2	U - L - C	2,5 - 4,0	5,5	B	Cover Stitch	5,0 *	N	16 mm	
	C1-C3-O2	"	"	"	"	"	"	"	16 mm	
Chain Stitch with 4 thread overlock	C2-C3-O2	"	"	"	"	"	"	"	13 mm	
	C1-O1	U - L - C	2,5 - 4,0	7,5	A	Chain Stitch	5,0 *	N	16 mm	
	C2-O1	"	"	"	"	"	"	"	13 mm	
5 Thread	C3-O1	"	"	"	"	"	"	"	10 mm	
	Chain Stitch with 3 thread overlock	C1-O1	U - L - C	2,5 - 4,0	7,5	A	Chain Stitch	5,0 *	N	16 mm
		C2-O1	"	"	"	"	"	"	"	13 mm
C3-O1		"	"	"	"	"	"	"	10 mm	

Notes : (U - L - C) = Upper - Lower - Chain looper

(*) = Tension settings on Chain Looper and on Cover/Stitch needles may vary depending on the threads.

Chart for stitch selection settings for Chain/Cover and Combination stitches

Stitch name	Nb. Needles & ndle position	Looper(s) U - L - C	Stitch L/dial	Stitch W/dial	Stitch Selector	Ch. looper tension dial	Ch/Cov ndle tension dial	Diff. Feed	Finish seam Width
5 Thread									
Chain stitch with 3 thread overlock	C-1 / C-2 / C-3	U - L - C	2,5 - 4,0	5,5	A	Chain Stitch	5,0 *	N	C1 - 16mm
	O - 1 (wide)	"	"	"	"	"	"	"	C2 - 13 mm
		"	"	"	"	"	"	"	C3 - 10 mm
Cover Stitch with 2 Thread overlock (Wide O-1) (Narrow O-2)	C1 - C2 - O1	L-C-sub looper	2,5 - 4,0	7,5	A	Cover Stitch	5,0 *	N	16 mm
	C1- C3 - O1	"	"	"	"	"	"	"	16 mm
	C2 - C3 - O1	"	"	"	"	"	"	"	13 mm
	C1 - C2 - O2	"	2,5 - 4,0	5,0	B	Cover Stitch	"	"	16 mm
	C1 - C3 - O2	"	"	"	"	"	"	"	16 mm
	C2 - C3 - O2	"	"	"	"	"	"	"	13 mm
4 Thread									
Triple Cover Stitch	C-1 / C-2 / C-3	C	2,0 - 3,0	M	-	Cover Stitch	5,0 *	N	
Chain Stitch with 2 Thread overlock (Wide O - 1) (Narrow O - 2)	C1 - O1	L-C-sub looper	2,5 - 4,0	7,5	A	Chain Stitch	5,0 *	N	16 mm
	C2 - O1	"	"	"	"	"	"	"	13 mm
	C3 - O1	"	"	"	"	"	"	"	10 mm
	C1 - O2	"	2,5 - 4,0	5,0	B	Chain Stitch	"	"	16 mm
	C2 - O2	"	"	"	"	"	"	"	13 mm
	C3 - O2	"	"	"	"	"	"	"	10 mm
3 Thread									
Cover St. Narrow	C1 - C2	C	2,0 - 3,0	M	-	Cover Stitch	5,0 *	N	
	C2 - C3	"	"	"	-	"	"	"	
	C1 - C3	C	2,0 - 3,0	"	-	Cover Stitch	5,0 *	N	
2 Thread									
Chain stitch	C-1	C	2,0 - 3,0	M	-	Chain Stitch	5,0 *	N	
	C-2	"	"	"	-	"	"	"	
	C-3	"	"	"	-	"	"	"	

Notes : (U - L - C) = Upper - Lower - Chain looper

(*) = Tension settings on Chain Looper and on Cover/Stitch needles may vary depending on the threads.

E8 英語
EI-44-En

Printed in Japan