

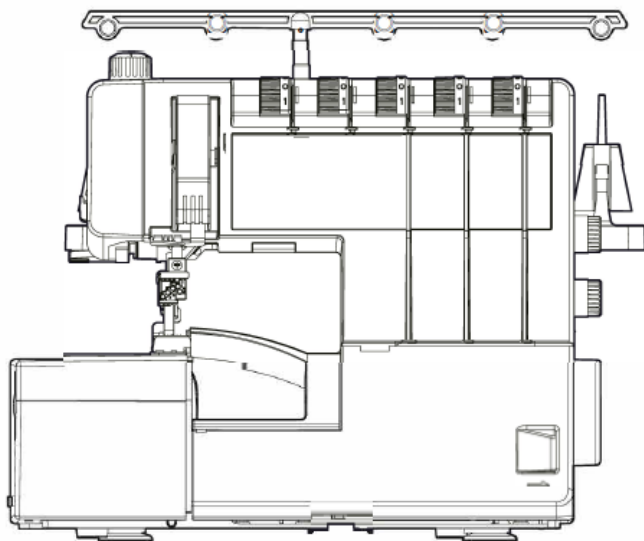

TRIUMPHATOR 2500X

Coverlocker



EN USER MANUAL

ES MANUAL DE USUARIO

FR MANUEL DE L'UTILISATEUR

DE BENUTZERHANDBUCH

IT MANUALE D'USO



EN

CONTENTS

1. Principal Parts	7
2. Accessories	9
3. Preparing To Sew	10
4. Telescopic Thread Guide / Cone Holders / Thread Net / Spool Cap	11
5. Needle Position / Presser Foot Lifting Lever	13
6. Changing A Needle	14
7. Connecting The Machine To The Power Source	15
8. Starting Sewing	16
9. Adjusting Presser Foot Pressure	17
10. Threading The Thread Guides	17
11. Threading The Upper Overedge Looper	18
12. Threading The Lower Overedge Looper	20
13. Double Chainstitch And Cover Stitch Looper	21
14. Threading The Needles	23
15. Needle Threader	26
16. Threading Schemes For All Types Of Programs	27
17. Thread Cutter	30
18. Disengaging The Upper Knife	31
19. Swiveling Stitch Width Finger	32
20. Right (Upper) Looper Converter	33
21. Disengaging The Upper Looper	34
22. Adjusting The Stitch Length/ Differential Feed	35
23. Removing The Knife Guard	36
24. Adjusting The Seam Width	37
25. Attaching The Presser Foot Holder	38
26. Replacing The Upper Knife	39
27. Care Of The Machine	40
28. Cover Stitches, Seam Stitches, Overlock Stitches, Setting Examples	42

ES

CONTENIDO

1. Nombres De Las Piezas.....	53
2. Accesorios Incluidos.....	55
3. Preparación Para Coser	56
4. Guiahilos Telescópico / Soportes De Conos / Portabobinas.....	57
5. Levantar El Prensatelas Y Las Agujas	59
6. Reemplazo De La Aguja.....	60
7. Conexión Eléctrica	61
8. Empezar A Coser.....	62
9. Ajuste De La Presión Del Prensatelas	63
10. Enhebrar Las Guías Del Hilo.....	64
11. Enhebrado De La Lanzadera Derecha (Superior).....	65
12. Enhebrado De La Lanzadera Izquierda (Inferior).....	66
13. Enhebrar El Bucleador De Costura Koverlock (Puntadas De Costura Y Recubrimiento).....	67
14. Enhebrado De Agujas.....	69
15. Enhebrador De Agujas Manual.....	72
16. Diagrama De Enhebrado General Para Todo Tipo De Programas.....	73
17. Cortador De Hilo Incorporado.....	76
18. Desconectar La Cuchilla Superior	77
19. Deshabilitar El Esparcidor.....	78
20. Convertidor De Bucleador Derecho (Superior).....	79
21. Deshabilitar El Bucleador Derecho (Superior).....	80
22. Ajuste De La Longitud De La Puntada Y El Avance Diferencial.....	81
23. Reemplazo Del Inserto Superior De La Tapa De La Lanzadera	82
24. Ajuste Del Ancho De Corte De La Tela	83
25. Instalación De La Valla	84
26. Reemplazo De La Cuchilla Superior.....	85
27. Cuidado De La Maquina.....	86
28. Cosido, Costura Y Puntadas De Koverlock, Ejemplos De Ajustes	88

TRIUMPHATOR 2500X

FR

CONTENU

1. Découvrez Votre Machine	99
2. Accessoires Inclus	101
3. Initiation À La Couture	102
4. Guide-Fil Télescopique / Porte-Bobine / Butée De Bobine	103
5. Relevage Du Pied-De-Biche Et Des Aiguilles.....	105
6. Remplacement De L'Aiguille.....	106
7. Branchement De L'Alimentation	107
8. Commencer À Coudre.....	108
9. Réglage De La Pression Du Pied De Biche	109
10. Enfilage Des Guide-Fils	109
11. Enfilage Du Boucleur Droit (Supérieur)	110
12. Enfilage Du Boucleur Gauche (Inférieur)	112
13. Enfilage Du Boucleur De Couture Pour La Boucle De Tapis (Points De Recouvrement Et De Couture).....	113
14. Enfilage De L'Aiguille.....	115
15. Enfile-Aiguille Manuel	118
16. Schéma Général De Threading Pour Tous Les Types De Programmes.....	119
17. Coupe-Fil Intégré	122
18. Déconnecter Le Couteau Supérieur	123
19. Désactiver Boucle Doigt	124
20. Convertisseur Boucleur Droit (Supérieur)	125
21. Désactiver Du Boucleur Droit (Supérieur).....	126
22. Réglage De La Longueur De Point Et De L'Avance Différentielle.....	127
23. Remplacement De L'Insert Supérieur	128
24. Réglage De La Largeur De Coupe Du Tissu	129
25. Fixation De La Règle	130
26. Remplacement Du Couteau Supérieur	131
27. Entretien De La Machine	132
28. Couture, Couture Et Points De Tapis, Exemples De Réglages.....	134

DE

INHALT

1. Lernen Sie Ihre	145
2. Inklusive Zubehör	147
3. Vorbereitung Für Das Nähen	148
4. Teleskopfadenführung / Spulenhalter / Garnrollenhalter	149
5. Nähfuß Und Nadellift.....	151
6. Austausch Von Nadeln	152
7. Anschließen Der Stromversorgung	153
8. Starten Sie Zu Nähen.....	154
9. Einstellen Des Nähfußdrucks	155
10. Einfädeln Der Fadenführungen	155
11. Einfädeln Des Rechten (Oberen) Greifers.....	156
12. Einfädeln Des Linken (Unteren) Greifers	158
13. Nahtgreifer Für Carpetlock Einfädeln (Cover- Und Absteppstiche).....	159
14. Nadeleinfädeln.....	161
15. Manueller Nadeleinfädler	164
16. Allgemeines Threading-Schema Für Alle Arten Von Programmen.....	165
17. Eingebauter Fadenabschneider.....	168
18. Trennen Des Obermessers	169
19. Abkoppeln Des Streuers	170
20. Rechter (Oberer) Knopflochkonverter.....	171
21. Deaktivieren Des Rechten (Oberen) Greifers.....	172
22. Einstellen Der Stichlänge Und Des Differentialtransports	173
23. Ersetzen Des Oberen Einsatzes Der Greiferabdeckung	174
24. Einstellen Der Schnittbreite Des Stoffes.....	175
25. Anbringen Des Lineals	176
26. Ersetzen Des Obermessers	177
27. Pflege Des Geräts	178
28. Nähen, Nähen Und Teppichstich, Beispiele Für Einstellungen.....	180



1. Conoscere La Macchina	191
2. Accessori.....	193
3. Preparazione Al Cucito	194
4. Asta Guidafile Telescopica / Porta Spole / Fermi A Disco Per Spolette.....	195
5. Salita Del Piedino E Degli Aghi	197
6. Sostituzione Degli Aghi	198
7. Allacciamento Elettrico	199
8. Inizio Del Cucito	200
9. Regolazione Di Pressione Del Piedino.....	201
10. Infilatura Delle Guide Dei Fili.....	201
11. Infilatura Del Crochet Destro (Superiore)	202
12. Infilatura Del Crochet Sinistro (Inferiore).....	204
13. Infilatura Del Crochet Della Catenella (Per Il Punto Di Co- pertura Ed Il Punto Catenella).....	205
14. Infilatura Degli Aghi	207
15. Infilatore Dell'Ago Manuale.....	210
16. Shema Generale Di Infilatura Per Tutti I Tipi Di Program- mi.....	211
17. Tagliafile Incorporato	214
18. Disattivazione Del Coltello Superiore	215
19. Disattivazione Dell'Allargatore.....	216
20. Convertitore Del Crochet Destro (Superiore).....	217
21. Disattivazione Del Crochet Destro (Superiore).....	218
22. Regolazione Della Lunghezza Del Punto E Del Trasporto Differenziale Della Stoffa	219
23. Sostituzione Dell'Insero Superiore Del Coperchio Dei Crochet	220
24. Regolazione Della Larghezza Di Taglio Della Stoffa... ..	221
25. Montaggio Del Righello Guida	222
26. Sostituzione Del Coltello Superiore	223
27. Manutenzione Della Macchina	224
28. Punti Di Copertura, Punti Catenella E Punti Overlock, Es- empi Di Regolazioni	226

BASIC SAFETY PRECAUTIONS

Please read this manual before using the machine.

Do not use the machine at an ambient temperature higher than 45°C or lower than 5°C, in humid rooms or outdoors, otherwise the machine may not work properly. To avoid condensation on electronic devices, it is not recommended to turn on the machine immediately after it has been moved from outdoors to indoors. It is necessary to wait until the machine reaches room temperature.

Do not use the device in unstable electrical network or in places where there is a strong electric or magnetic field, otherwise the machine will malfunction. It is necessary to install the machine on a flat stable surface, taking into account the required distance from fixed objects.

Do not drop the machine as this may result in injury or damage to the machine.

OPERATING THE MACHINE

Be careful when operating the machine; protect your hands from getting into the working area of moving parts, especially in close proximity of needles. To avoid electric shock or short circuit, make sure that all cables are in good condition and not damaged (cuts, burns, etc.), not in contact with damp or corrosive environments. The power cable must have good contact with the mains. When disconnecting the power cable from the mains, do not pull on the cable.

SAVE THESE INSTRUCTIONS

This machine is intended for domestic use only.

This device is not intended for use by persons (including children) with reduced physical or mental capabilities, or lack of knowledge and skills, unless they are supervised or trained by a person responsible for their safety. Supervise children and prevent them from playing with this device.

If the operating conditions and storage rules of the machine are observed, the service life will be at least 8 years.

PRINCIPAL PARTS

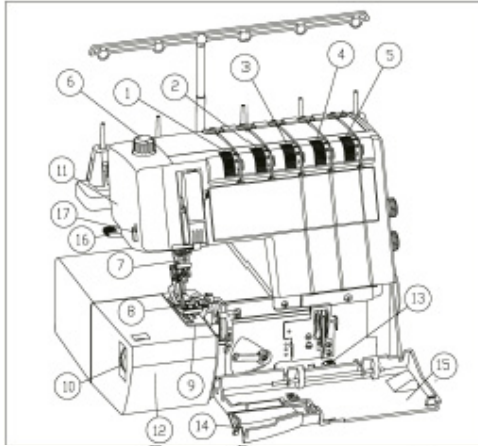

- 1 . Upper needle-thread tension
- 2. Upper needle-thread tension
- 3. Thread tension/ upper looper thread
- 4. Thread tension/ lower looper thread
- 5. Thread tension/ two-thread chainstitch looper/ cover stitch looper

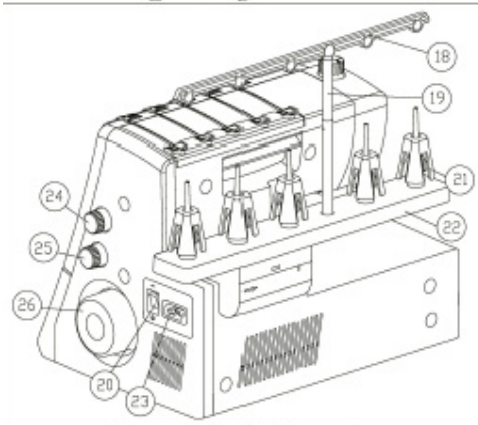

- 6. Adjusting knob for presser foot pressure
- 7. Needle holder
- 8. Standard presser foot
- 9. Needle plate
- 10. Adjusting knob for seam width
- 11. Lamp cover
- 12. Swivel plate

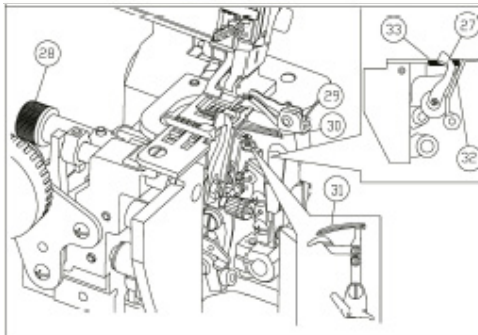

- 13. Looper disengaging lever
- 14. Blade guard (for Overedge/ Overlock)
- 15. Looper cover
- 16. Presser foot lever
- 17. Thread chain cutter

18. Thread guides
19. Telescoping thread guide
20. Electrical power master switch
21. Cane thread adapter
22. Thread spool stand
23. Machine socket, foot control
24. Stitch length adjustment knob
25. Differential feed adjustment knob
26. Handwheel
27. Movable upper knife
28. Knob for lowering the upper knife
29. Upper overedge looper
30. Lower overedge looper
31. Double chainstitch and cover stitch looper
32. Swiveling stitch width finger
33. Fixed lower knife

ACCESSORIES

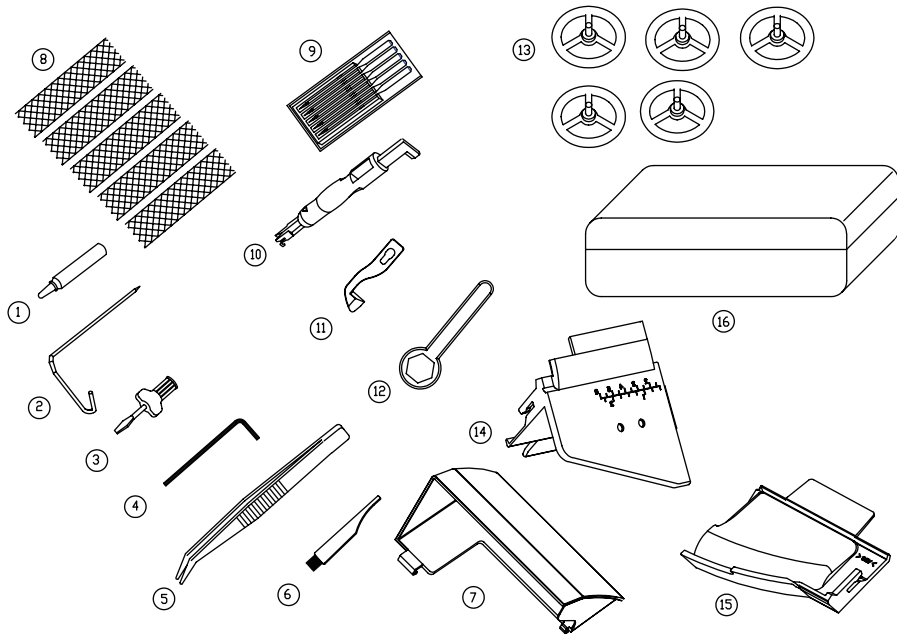

- | | |
|------------------------|--|
| 1. Oil bottle | 10. Needle threader |
| 2. Edge/Quitting guide | 11. Upper blade |
| 3. Screwdriver | 12. Wrench |
| 4. Hex Wrench | 13. Spool cap (5 pcs.) |
| 5. Tweezers | 14. Sewing table (for Coverstitch/Chainstitch) |
| 6. Cleaning brush | 15. Blade guard |
| 7. Waste bin | 16. Accessory box |
| 8. Thread nets (5pcs). | |
| 9. Pack of needle | |

PREPARING TO SEW

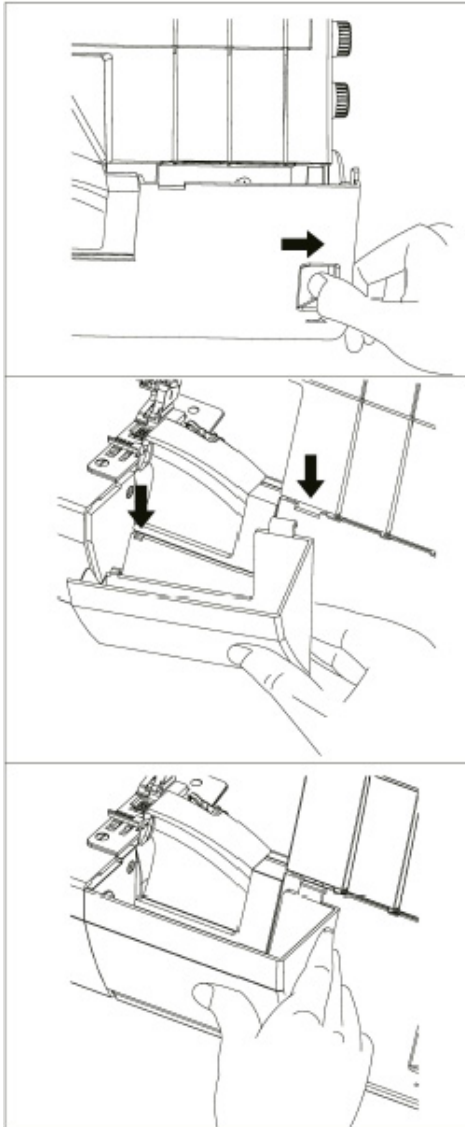

Looper Cover

Push the looper cover fully to the right and then swivel it down.

Waste Bin

Insert the upper latch of the waste bin into the upper slot of the looper cover. Apply pressure to the lower part of the bin until the lower latches fit into place in the lower slots of the looper cover.

To remove the waste bin, repeat this procedure in the reverse order.

TELESCOPIC THREAD GUIDE / CONE HOLDERS / THREAD NET / SPOOL CAP

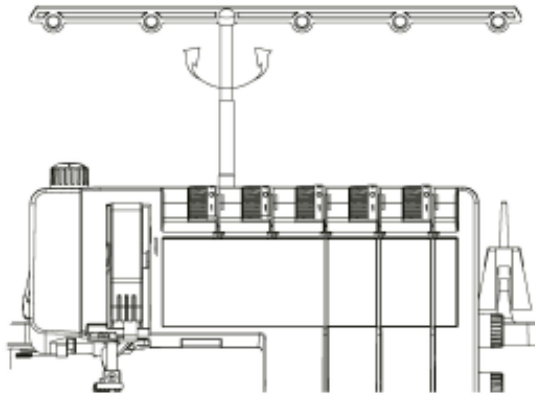

Telescopic Thread Guide

Pull the telescopic thread guide upwards to its highest position. To ensure optimum thread feed, turn the telescopic parts slowly until you hear the locking balls fick into place.

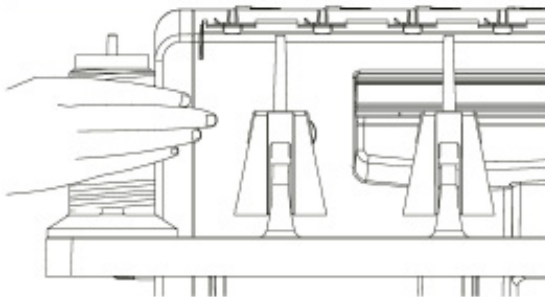

Foam Pads/ Cone Holders

If you are using large cones (5,000 -10,000 mm), the foam pads and the cone holders will be helpful to you.

With synthetic threads, the foam pads catch threads that have slipped down and help to advance the thread flawlessly.

Cone holders serve to ensure that large cones are well positioned.

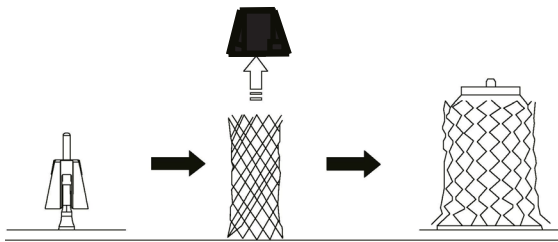

- 1) Spool pin
- 2) Cone holder
- 3) Spool cap

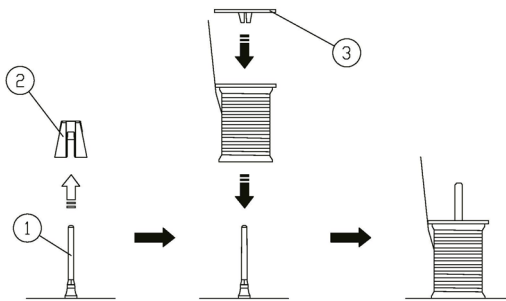

Thread Net / Spool cap

Synthetic threads generally unwind too quickly from the thread spool.

Thread nets have been included to allow easy use of these threads. Pull the thread net (located in the accessory box) over the spool from below. Place the spool on the spool holder catching the bottom of the thread net with the spool pin.

When using small spools, remove the spool holders from the spool pins. Place the spool with its slit side up, and put the spool cap on top of it.

NEEDLE POSITION / PRESSER FOOT LIFTING LEVER

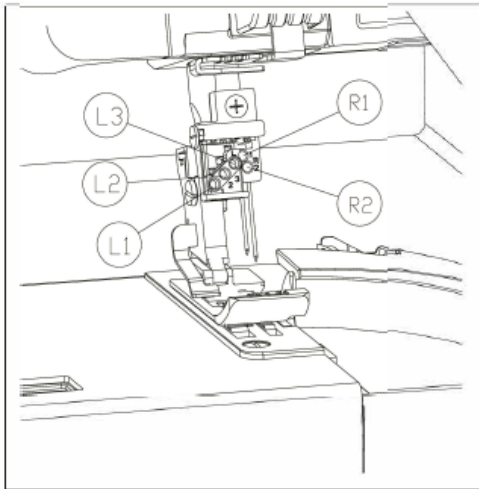

The offers a choice of 5 needle positions. You can sew with as many as 3 needles simultaneously. The needle positions are L 1 , L2, L3, R1 and R2. A retaining screw is provided above each needle.

△ NOTE:

If the needles are inserted at R1 and R2, the left needle is slightly higher than the right.

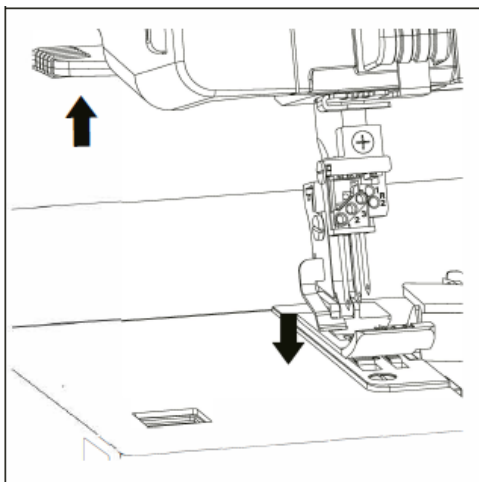

If the needles are inserted at L2 and L3, the left needle is slightly lower than the right. If the needles are inserted at L 1 and L3, the left needle is also lower than the right. If the needles are inserted at L 1 , L2 and L3, the left needle is at the lowest point.

The presser foot can be up or down position by using the presser foot lifting lever.

△ NOTE:

Presser foot should be lowered when sewing.

CHANGING A NEEDLE

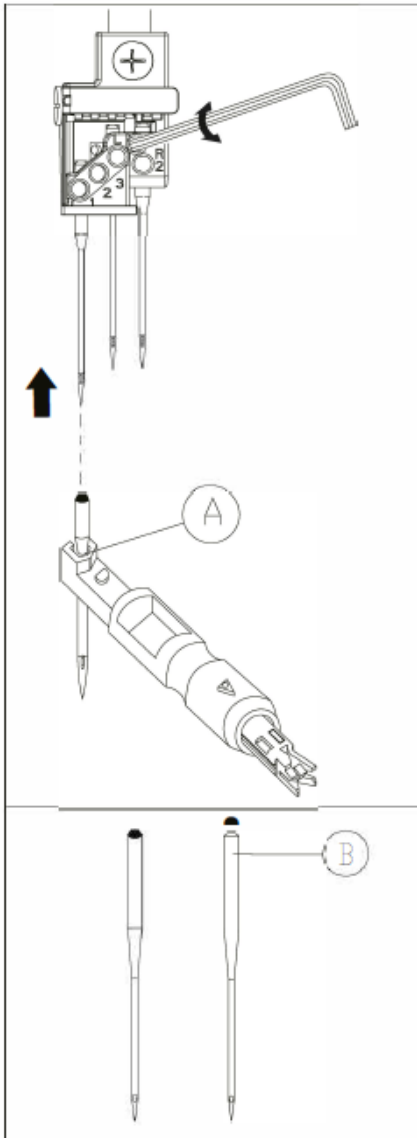

Turn off at the power switch

To remove: Lower the presser foot and raise the needle(s) to its/their highest position. Take the needle changing tool out of the accessory box and push it up over the needle as far as it will go. Loosen (but do not remove) the needle's retaining screw with the allen key and pull the needle out from below.

To insert: Insert the needle in hole A of the needle changing tool so that the flat side B of the needle is opposite face of the tool. Insert the needle as far as it will go into the needle holder (you may have to push a little harder by hand) and tighten the retaining screw. Remove the needle changing tool.

Needle System	Needle Size	Type of Fabrics
EL x 705	11-14 (75-90)	Light to medium weight fabrics such as silk, cottons, shirts, blouse fabrics, stretchy fabrics, denim & etc.

CONNECTING THE MACHINE TO THE POWER SOURCE

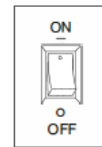
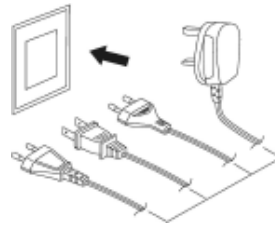
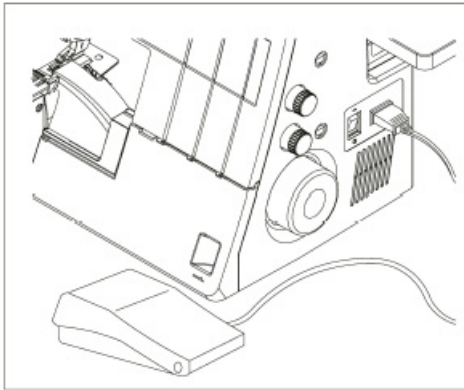

Before connecting the power supply, make sure that the voltage and frequency shown on the machine is conforming with your electrical power.

Place machine on a stable surface.

1. Connect the power line cord to the machine by inserting the 3 pin plug into the power cord socket.
2. Connect the power line plug to the electric outlet.
3. Turn on the power switch.
4. The sewing lamp will light up when the switch is turned on.

To disconnect, turn the power switch to the off position, then remove plug from outlet..

STARTING SEWING



With the sewing machine turned off, insert the foot control plug into its connector on the sewing machine.

Turn on the sewing machine, and then slowly depress the foot control to start sewing.

Release the foot control to stop the sewing machine.



Warning!

Consult a qualified electrician if in doubt as to how to connect the machine to the power source. Unplug the power cord when the machine is not in use.

Unplug power cord when machine is not in use.

The foot control must be used with the appliance by YC-482 (110-120V area) / YC-483-5 (220-240V area).

ADJUSTING PRESSER FOOT PRESSURE

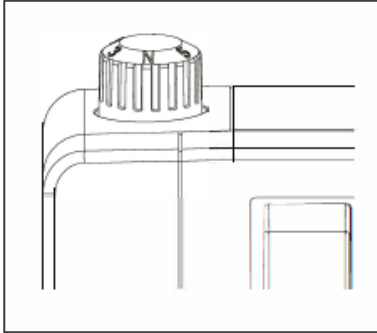

The preset presser foot pressure on the machine is suitable for medium fabrics. For most fabrics, the presser foot pressure does not need to be altered. If you intend to work with lighter or heavier fabrics, however, it may be necessary to reset the pressure. In this case, you can choose from six positions; make your selection with the presser foot pressure adjustment knob. The standard setting is «N» .

△ NOTE:

Lower the presser foot before turning the presser foot pressure adjustment knob. This makes the knob easier to turn.

THREADING THE THREAD GUIDES

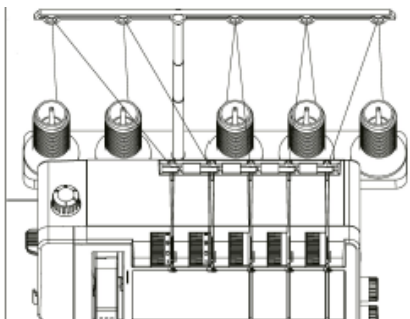

Place the spools on the spool pins. For notes on the spool net, the thread run-off disc, the foam pads and the cone holders. Thread the threads from the back to the front through the thread guides as indicated by the codes.

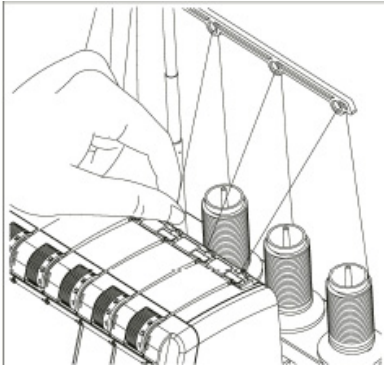

After threading the thread guide bar, slip the thread into the first guide on the machine.

To do this, pull the thread down with both hands until it slips under the thread guide. Pass the thread between the tension discs and pull it down so that it is between the tension discs.

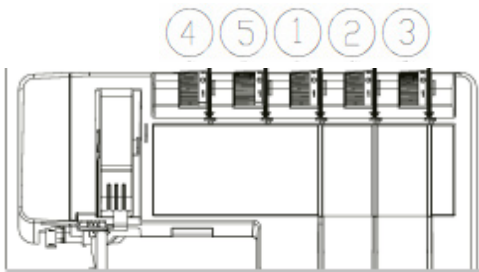

△ NOTE:

Thread in a sequence of 1 to 5.

THREADING THE UPPER OVEREDGE LOOPER

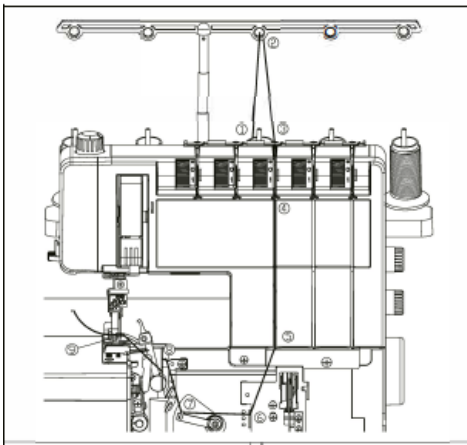

Upper looper (green)

Turn the hand wheel towards you until the upper looper reaches its highest position. Thread the threads in order from 1 to 9. Some of the thread guides are marked with a green dot.

A : Upper looper

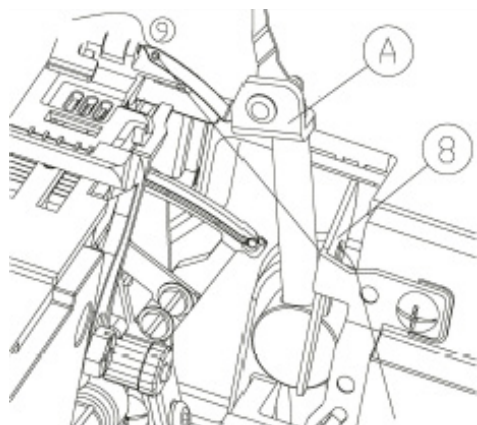

Thread the thread in thread guides 1 to 7. Pass the thread over the top of guide 8 from above and pull it down and to the left until it slips into the guide.

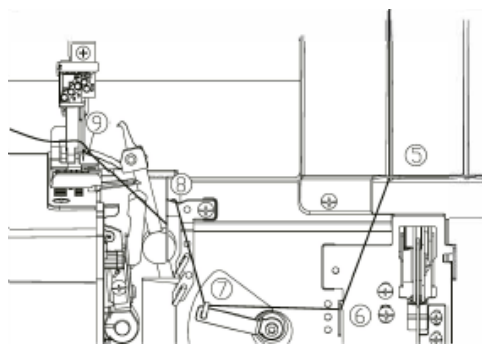

From the front, pass the thread through the eye 9 of the upper looper. Pull about 10cm (5 inches) of thread through the hook and place it facing to the left under the presser foot.

THREADING THE LOWER OVEREDGE LOOPER

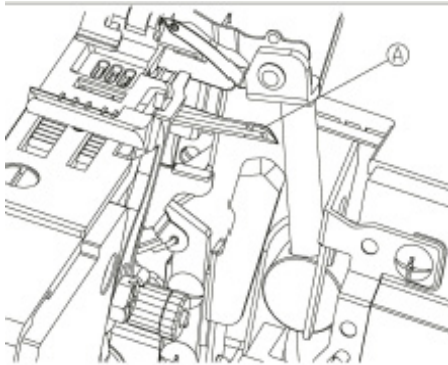

Threading Lower Looper (pink)
Turn the hand wheel towards you until the lower looper is as far to the right as possible.

A: Lower Looper

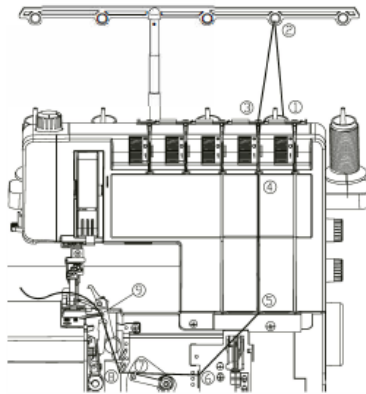

Thread the thread in order from 1 to 9. Some of the thread guides are marked with a pink dot.

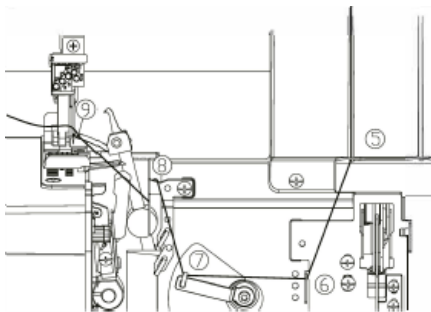

Push lever (a) down and hook the thread on the guide (b). Pass the thread from front to back through the hole (c) on far right end of the looper. Draw the thread back to the left under the presser foot, leaving a 10cm (4 inches) tail.

DOUBLE CHAINSTITCH AND COVER STITCH LOOPER

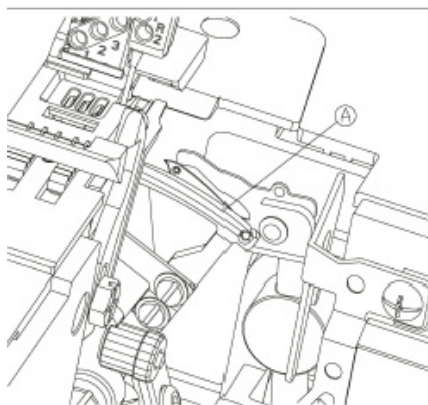

Double chainstitch(blue)
 Turn the hand wheel towards you until the double chainstitch and coverstitch looper is as far to the right as possible.
 A: Double chainstitch and coverstitch looper

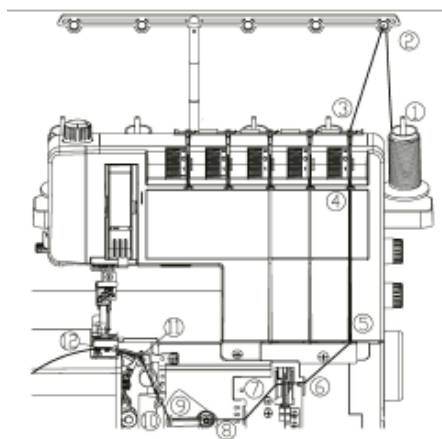

Thread the thread in order from 1 to 12. Some of the thread guides are marked with a purple square.

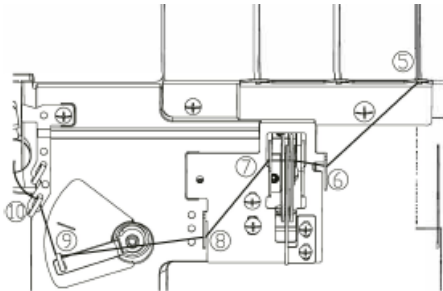

Thread the thread in the guides from 1 to 8. Pull the thread under latch 9 and into thread guide 10.

△ NOTE:

In the case of thread, guides 6 and 7, the thread is simply placed on top of them, not threaded through.

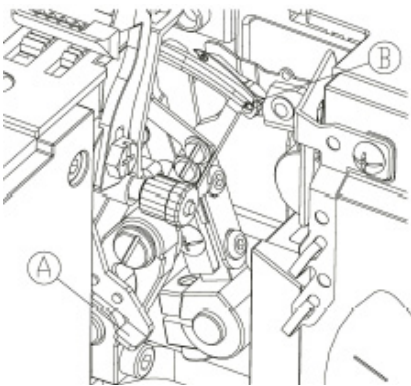

Press lever **A** up and hook the thread into slot **B**. The illustration right shows how to do this.

△ NOTE:

The lever will return to its original position as soon as you start to sew.

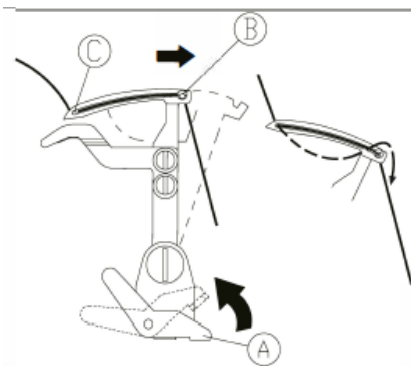

From the front, pass the thread through eye **C** of the double chain stitch and cover stitch looper.

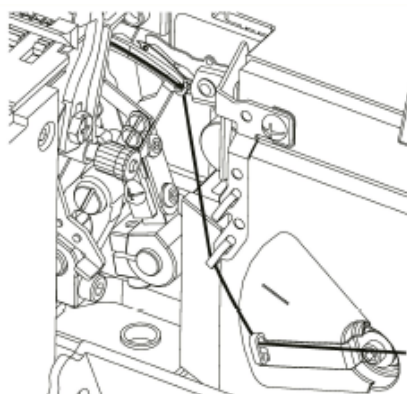

Pull about 10cm (4 inches) of thread through the looper and place it to the left under the presser foot.

THREADING THE NEEDLES

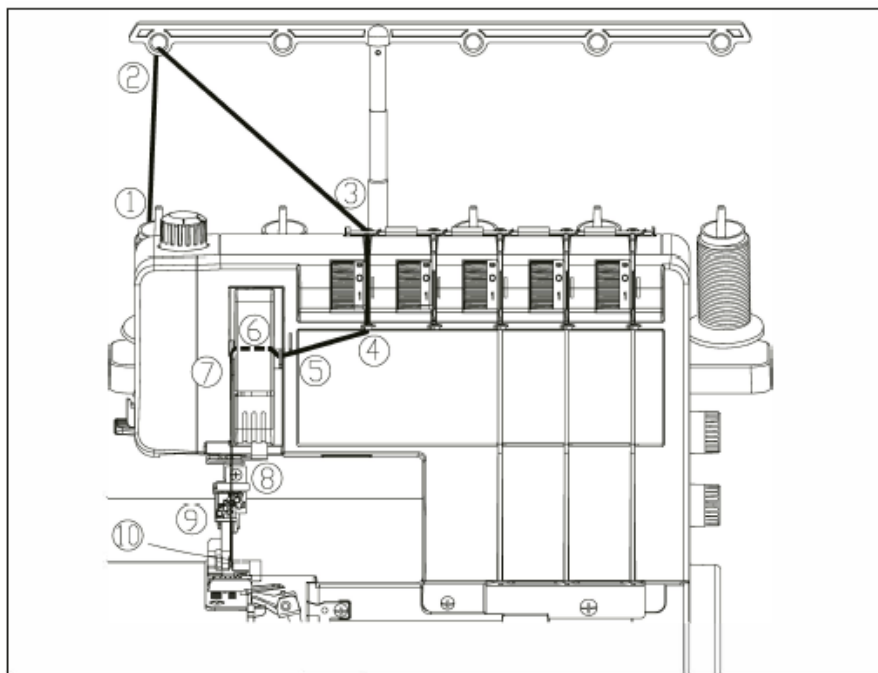

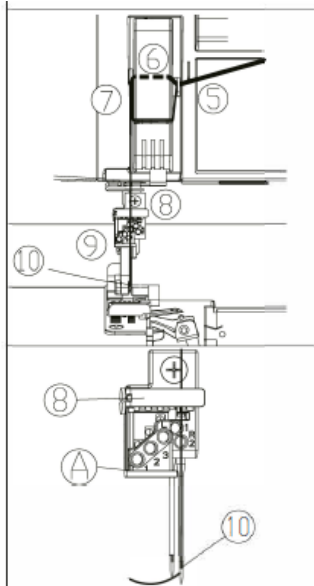

Thread the thread in order from 1 to 10.

The thread must pass through the lower slot in thread guide 5.

Pull the thread about 10 cm (4 inches) through the eye of the needle and place it facing to the left under the presser foot.

If you sew with the needles L1, L2, or L3 you have to use the thread guide A.

A : thread guide A.

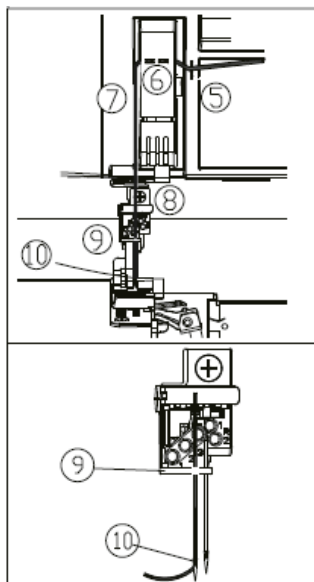

Exception: Threading needle L3 when sewing a 5-thread safety-stitch seam (Prog. 20), a 4-thread safety-stitch seam (Prog. 19) and a 2-thread chainstitch (Prog. 04). Thread in a sequence of 1 to 10.

The thread must pass through the upper slot in thread guide 6.

Pull the thread about 10 cm (4 inches) through the eye of the needle and place it facing to the left under the presser foot.

△ NOTE:

To thread the double chainstitch (prog. 04) you have to thread the green tension.

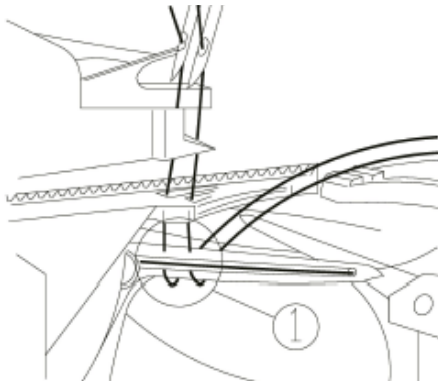

Important note on threading

The needles must always be threaded last so that the needle threads do not run under the looper thread as seen in drawing 1, but instead over the looper thread as depicted in drawing 2. Should this sequence not be followed, thread breakage or missed stitches can occur.

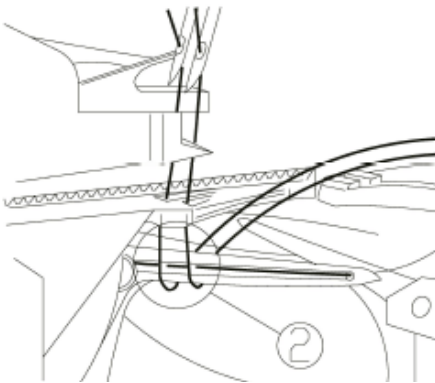

If the looper threads break, you must pull the needle threads out of the needle eye, rethread the looper thread and then rethread the needle threads.

NEEDLE THREADER

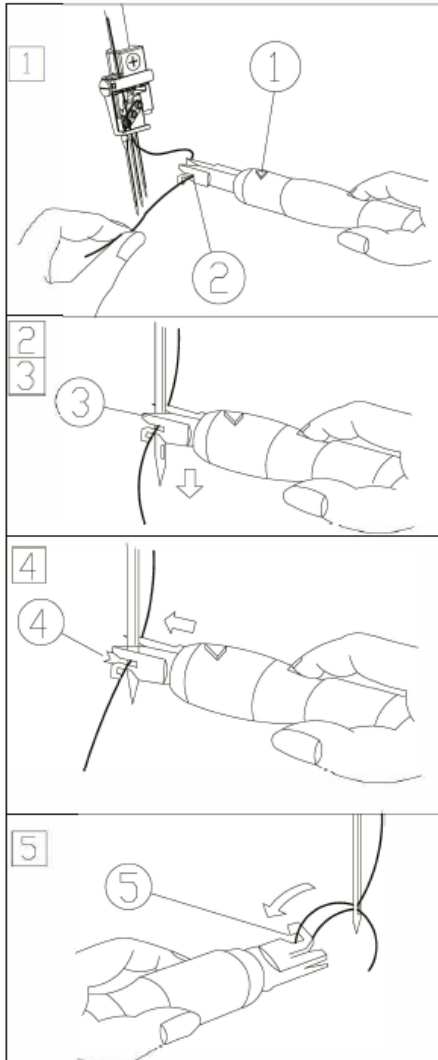

! Turn off at the power switch

Raise the needles into their highest position and lower the presser foot. Place the thread running from right to left in notch A of the needle threader (the needle threader is included in the accessory box). One of the two triangles must be pointing upwards.

Place the needle threader against the front groove of the needle. Move down as far as the eye of the needle and press the threader gently against the needle. This causes a small metal pin to pass through the eye and the needle is threaded automatically.

△ NOTE:

If you press too hard, the small metal pin will bend and you will no longer be able to use the threader to thread the needle.

Now you can use the needle threader to pull the thread loop through to the rear.

THREADING SCHEMES FOR ALL TYPES OF PROGRAMS

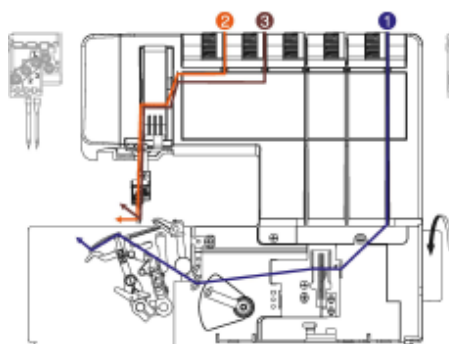

Program 01
2-needle cover hem, narrow (L2/ L3)

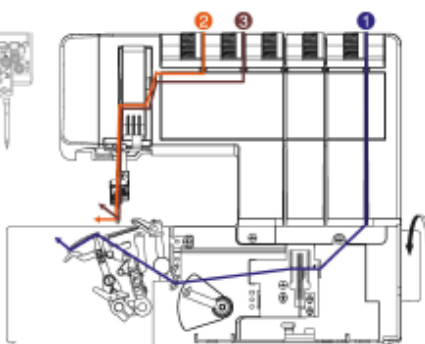

Program 02
2-needle cover hem, wide (L1/ L3)

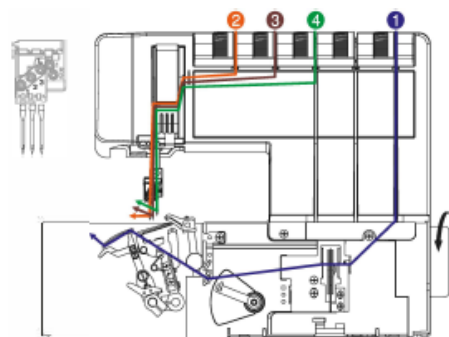

Program 03
3-needle cover hem (L1/ L2/ L3)

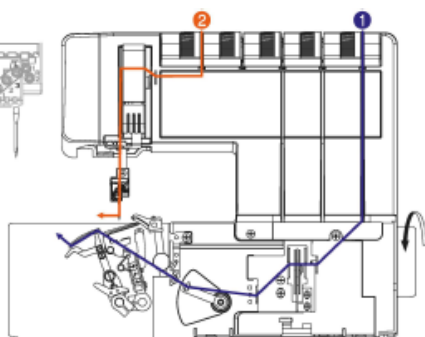

Program 04
Chainstitch(L3)

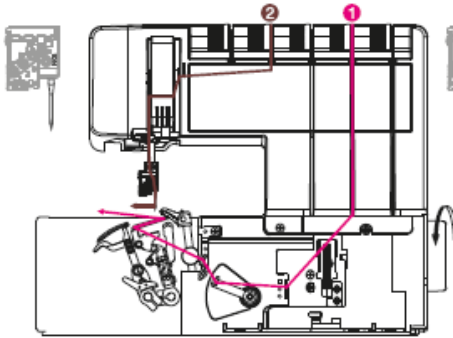

Program 05
2-thread flatlock, narrow (R2)

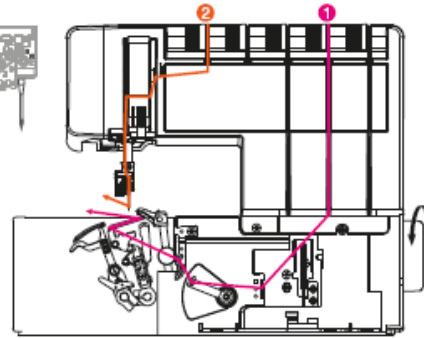

Program 06
2-thread flatlock, wide (R1)

Program 07
2-thread serging, narrow (R2)

Program 08
2-thread flat hem (R2)

Program 09
2-thread fold. Rolled hem (R2)

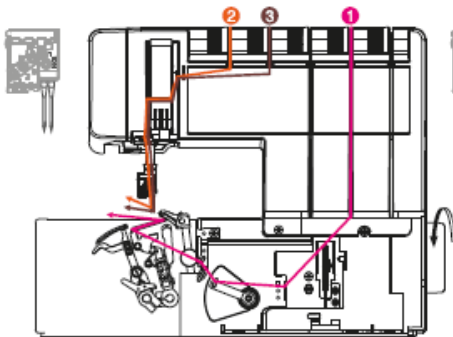

Program 10
2-needle, 3-thread overedge seam
(R1/R2)

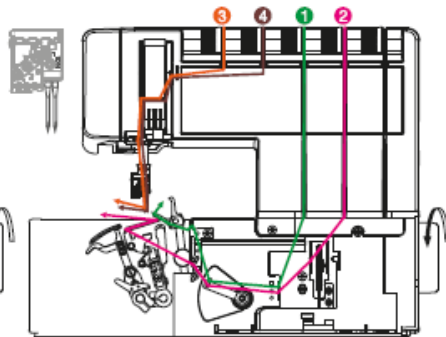

Program 11
4-thread overedge seam (R1/ R2)

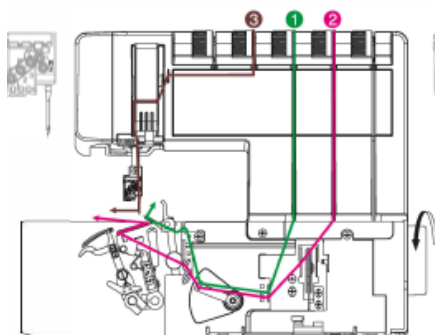

Program 12
3-thread overedge seam, narrow (R2)

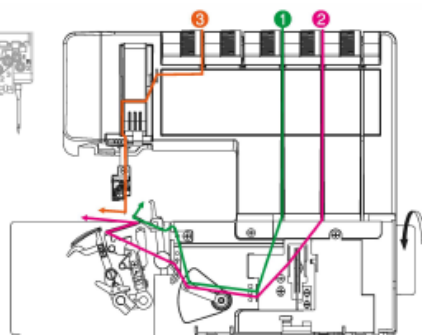

Program 13
3-thread overedge seam, wide (R1)

Program 15
3-thread flatlock, narrow (R2)

Program 14
3-thread serging, wide (R1)

Program 17
3-thread flat hem (R2)

Program 16
3-thread flatlock, wide (R1)

Program 18
3-thread fold. Rolled hem (R2)

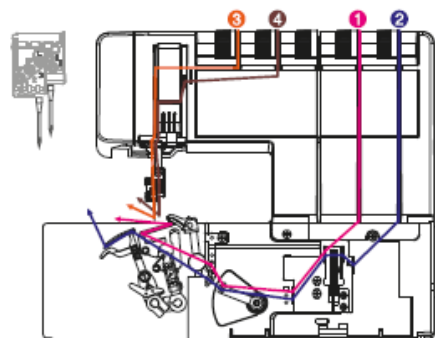

Program 19
4-thread safety stitch, wide (L3/R1)

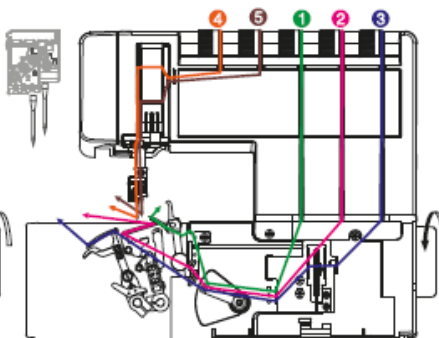

Program 20
5-thread safety stitch, wide (L3/ R1)

THREAD CUTTER

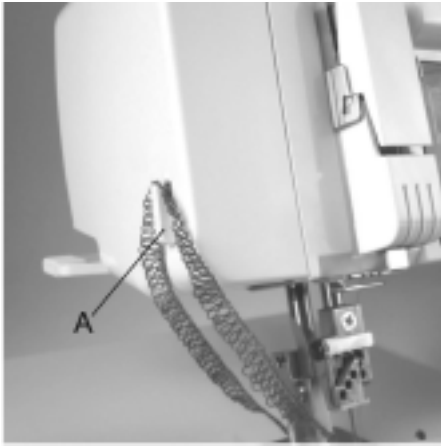

At the end of a seam, sew a thread chain of 15 to 20 cm and pull the thread chain from back to front over the thread chain cutter. This will cut off the thread chain.

A: Thread cutter



Place the fabric just in front of the needles. If necessary, first cut about 3 cm along the cutting line with a pair of scissors. Lower the presser foot and start sewing. The thread chain will be drawn inside the seam automatically.

△ NOTE:

If you press too hard, the small metal pin will bend and you will no longer be able to use the threader to thread the needle.



Attach the waste bin to the front cover. The tray will catch fabric scraps that are cut off.

DISENGAGING THE UPPER KNIFE

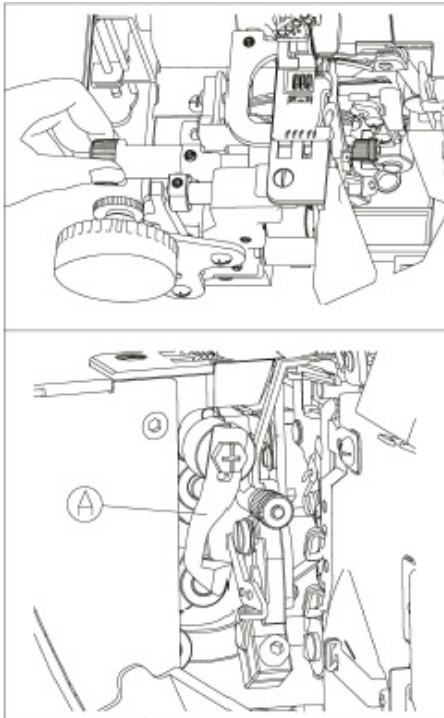

! Turn off at the power switch

Remove the trim catcher and open the front cover and the swivel table. Raise the upper knife to its highest position by turning the hand wheel. Now push the knob for lowering the upper knife as far as it will go to the right. **A:** Upper knife

Turn the knob towards you until the upper knife is seated in its lowest position. The upper knife is now disengaged.

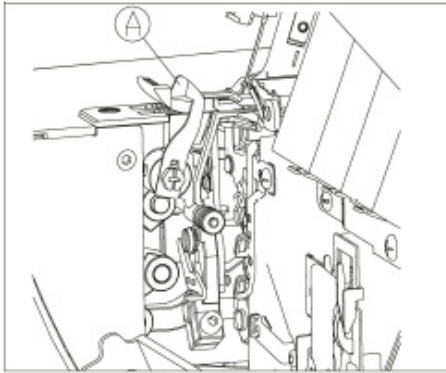

Engage the upper knife. Push the knob for lowering the upper knife to the right and swing the knife back until it clicks back into its working position. Close the front cover and the swivel table and reattach the trim catcher.

SWIVELING STITCH WIDTH FINGER

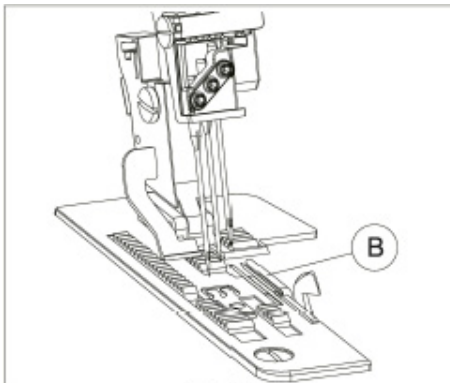

For Standard Overlock Seams:
For sewing all standard overlock seams (ex. progs. 02, 04) the swiveling stitch width finger remains in its engaged position.

A: Stitch width finger knob
B: Stitch width finger

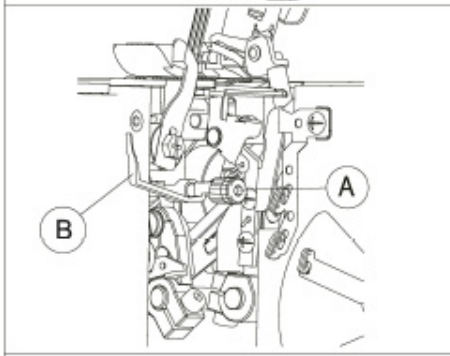

For rolled hems
Remove the trim catcher and open the front cover.
Pull knob **A** of the swiveling stitch width latch to the right and swing it down into its disengaged position.

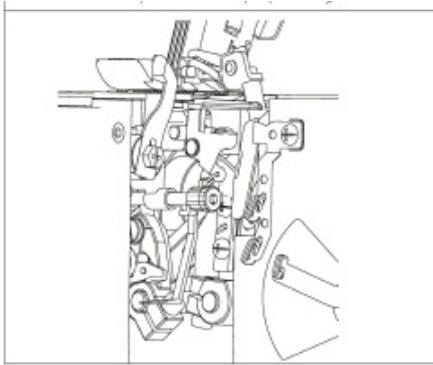

You can sew all rolled hems with this setting. This setting is also used for sewing coverstitches, double chain stitch, top cover and deco cover (progs. 02, 04).

RIGHT (UPPER) LOOPER CONVERTER

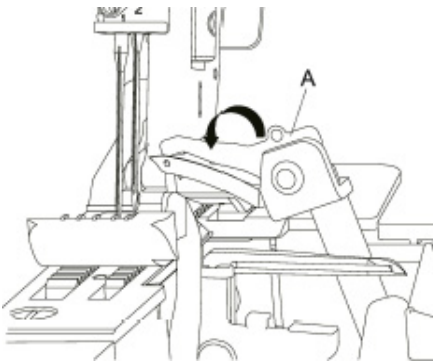

To engage the 2-thread converter: Hand turn the handwheel until the lower looper is in an up position. Lower the converter and insert the hook into the lower looper.

A: 2-thread converter

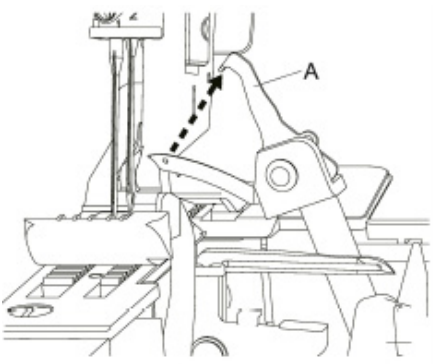

To disengage the 2-thread converter: Hand turn the handwheel until the lower looper is in an up position.

Remove the hook from the looper eye and lift the converter up until it secures in the far right position.

DISENGAGING THE UPPER LOOPER

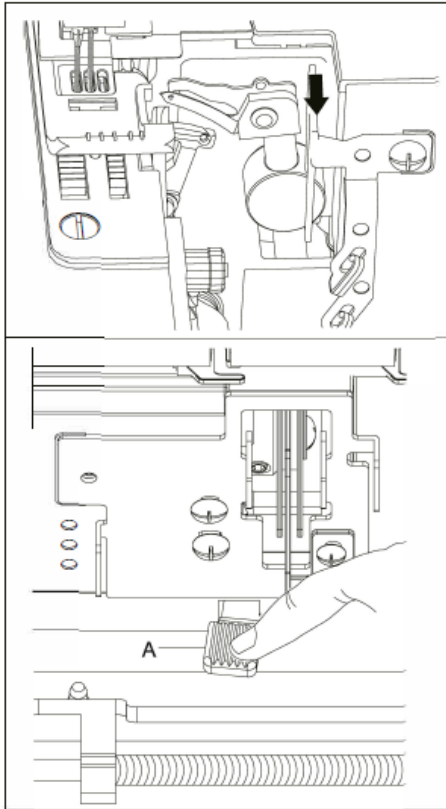

You can disengage the upper overedge looper with the upper looper disconnection lever. Remove the trim catcher and open the front cover. Turn the hand wheel to bring the looper to its lowest position.

A: Upper looper disconnection lever

Press the upper looper disconnection lever down and push it to the left. Turn the hand wheel to ensure that the looper is indeed disengaged.

To engage the upper looper, push the upper looper disconnection lever into its position to the right. Turn the hand wheel until the looper engages with an audible click and moves upwards again. Close the front cover and attach the trim catcher.

ADJUSTING THE STITCH LENGTH/ DIFFERENTIAL FEED

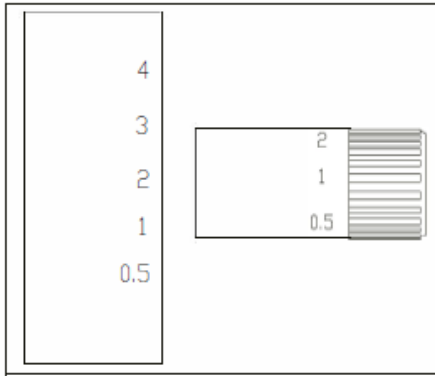

Turn the regulator wheel for differential feed to select the stitch length shown on the display panel by setting the number to the setting mark. Stitch length may be set from 0.5 to 4.

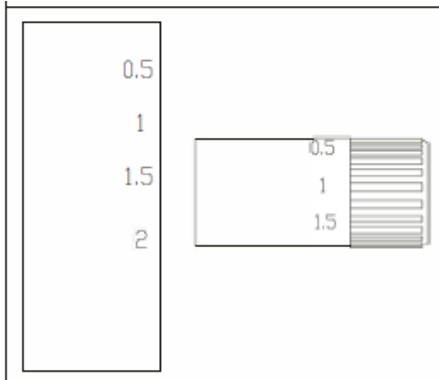

Turn the regulator wheel for differential feed to select the differential ratio shown on the display panel by setting the number to the setting mark. Differential feed may be set from 0.5 to 2.

REMOVING THE KNIFE GUARD

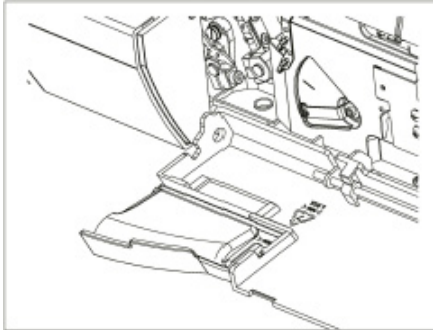

Remove the trim catcher and open the front cover.

Pull the knife guard up and off.

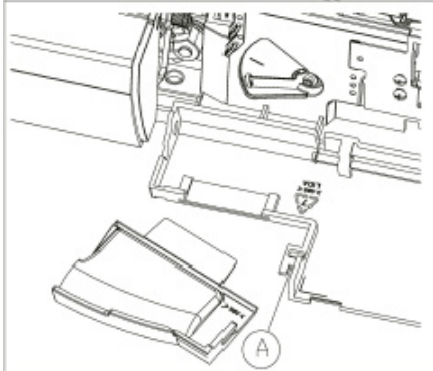

To insert, place the knife guard under latch A and push down into the front cover guides.

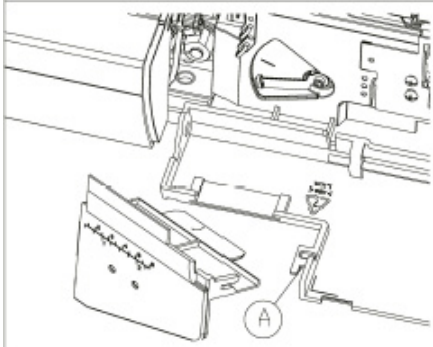

Important notes on sewing with the top cover stitch sewing table. The sewing table is marked with various measurement units. The figures at the top are centimeters, those at the bottom represent inches.

△ NOTE:

The sewing table (accessory) is attached in the same way.

ADJUSTING THE SEAM WIDTH

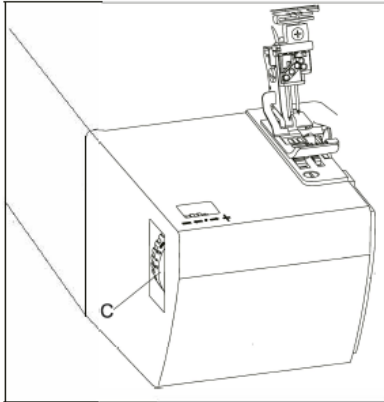

Turn the seam width adjustment knob to select any seam width value from 3.5 to 6.0 mm; it will also be displayed in the viewing window. (Double chain stitch is sewn with a gap of 6.5 to 9 mm.)

C: Seam width adjustment knob

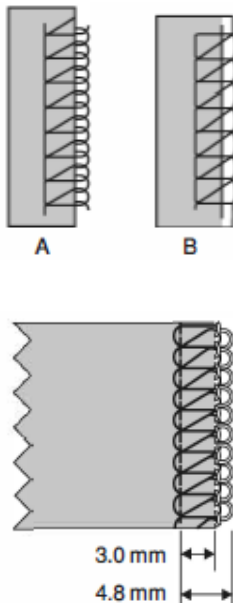
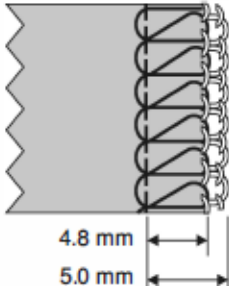
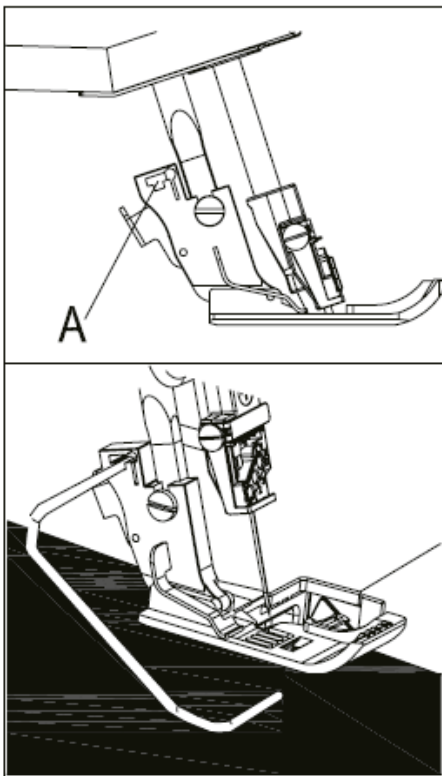

Figure A: If loops are protruding from the edge of your seam, turn the seam width selection knob upwards to shift the upper knife to the right. Figure B: If your seam puckers at the edge, turn the seam width selection knob downwards to shift the upper knife to the left.

△ NOTE:

The seam width settings 4.8 mm and 5.0 mm are only relevant for the needle R1. This set-value is reduced by 2.0 mm when using the needle R2. you have a seam width which is completely adjustable from 3.0 mm to 4.8 mm.

ATTACHING THE PRESSER FOOT HOLDER

! Turn off at the power switch

Slide the edge/ quilting guide from the accessory box left to right into guide A of the presser foot holder. You can adjust the ruler as you wish by sliding it in the guide.

This setting allows you to sew all types of rolled hems.

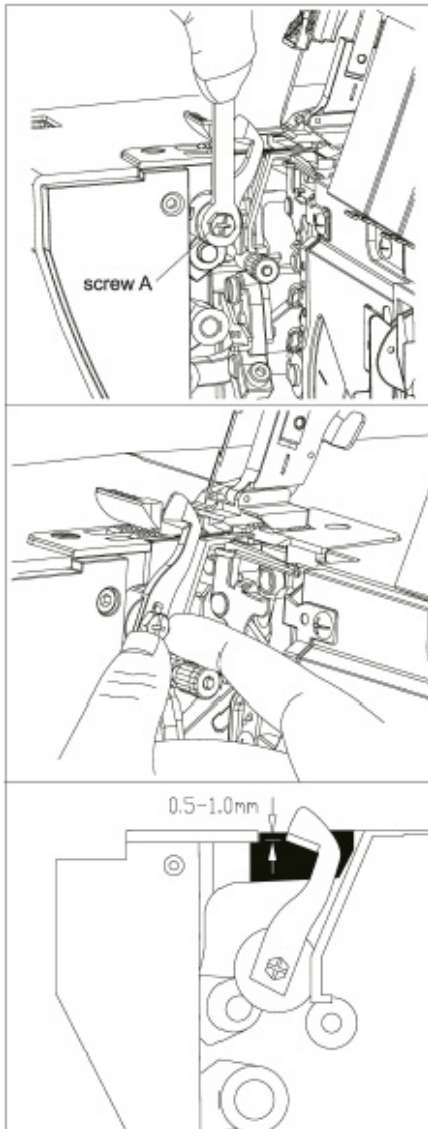
REPLACING THE UPPER KNIFE



Removal: Set the seam width adjustment knob to 3.5mm and secure the upper knife in place. Loosen screw A with the spanner from the accessory box and remove the upper knife.

Insertion: Insert the new upper knife and tighten screw A very slightly. Turn the hand wheel until the upper knife is in its lowest position.

In this position, the front edge of the upper knife must be 0.5 to 1.0 mm below the cutting edge of the lower fixed knife.

When you have adjusted the upper knife precisely, you can tighten retaining screw A fully. Loosen the screw to the upper knife.

CARE OF THE MACHINE

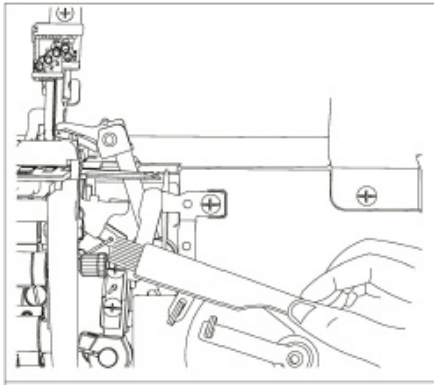

! Turn off at the power switch

Cleaning of the machine.

Remove the top cover hook or decorative thread guides. Remove the trim catcher, open the front cover and the swivel table. Disengage the upper knife. Remove the presser foot and the needle plate. With the lint brush provided in the accessory box, remove lint from the upper and lower knives, the differential feed and the looper area.

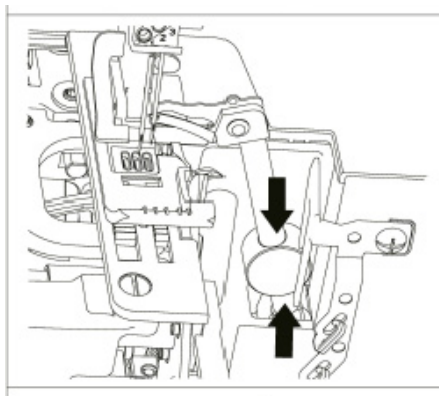

Oiling the machine

Bring the upper looper to its highest position by turning the hand wheel. After every cleaning of the machine, oil the points shown with the oil included in the accessories. One or two drops of sewing machine oil are sufficient. All other parts are made from special materials and do not need to be oiled.

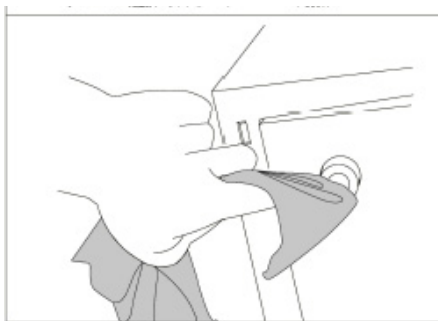
**Cleaning rubber feet.**

Clean the rubber feet of the machine with methyl alcohol from time to time. This will ensure that the machine will not move on the surface on which it is standing.

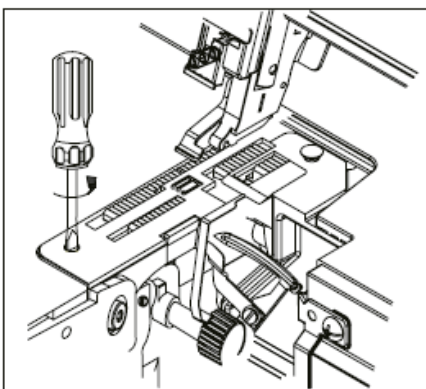

Removing the needle plate
Remove the needle, presser foot, and presser foot holder.

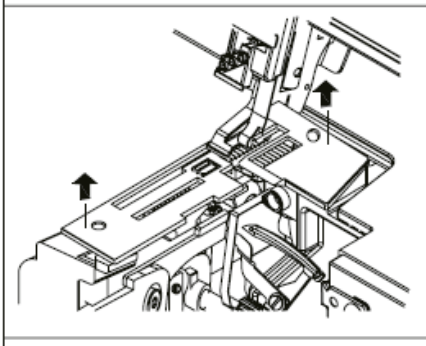



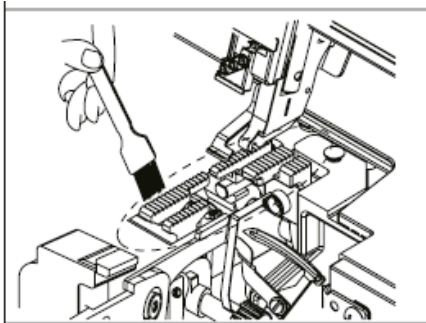



Remove the screws holding the needle plate and remove the needle plate.

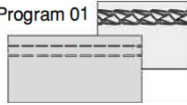
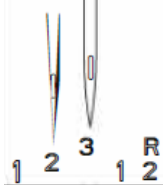

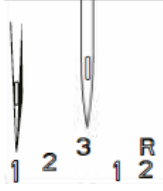

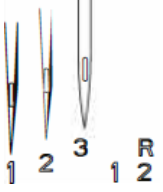

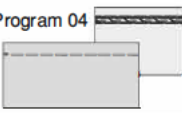
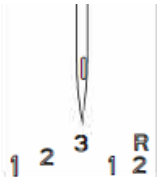
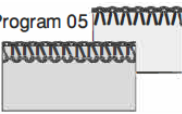
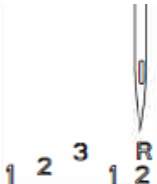
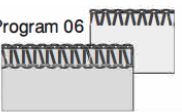
Clean the hook race, feed dog and bobbin case with a brush. Also clean them, using a soft, dry cloth.

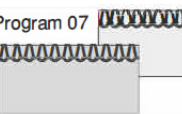
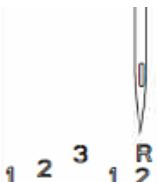
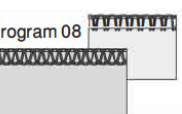
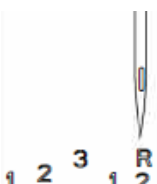

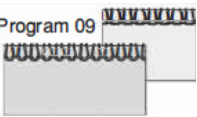
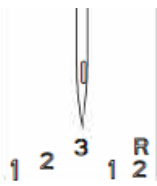
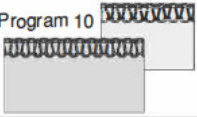
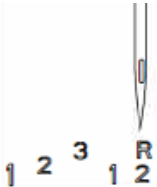
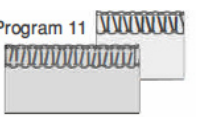
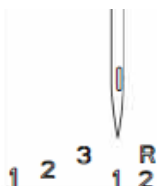

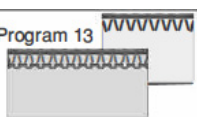
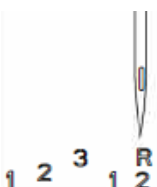
COVER STITCHES, SEAM STITCHES, OVERLOCK STITCHES, SETTING EXAMPLES

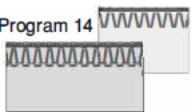

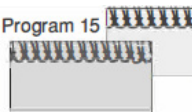
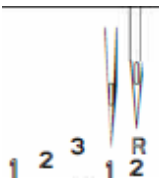
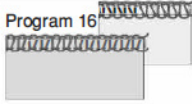
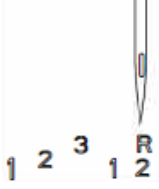
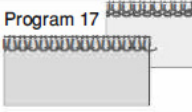
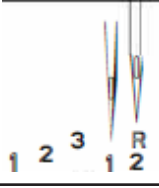
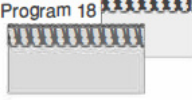
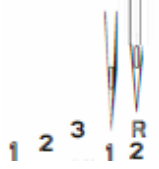



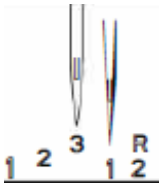

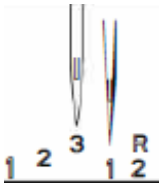

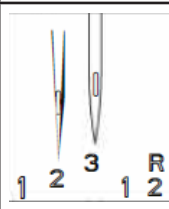

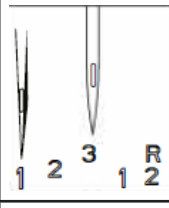
Programmes	Application	Needle position	Stitch length	Stitch width	Thread tension
Program 01 	For hemming stretch fabrics and piping, for decorative effects.		2.5	5.0	5.0 5.0 _ _ 1.0
Program 02 	For hemming stretch fabrics and for decorative effects.		3.0	5.0	5.0 5.0 _ _ 1.0
Program 03 	For hemming highly stretch fabric and for decorative effects.		3.0	5.0	5.0 4.5 5.0 _ 1.0





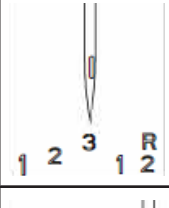

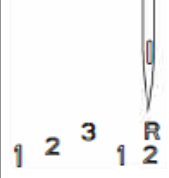

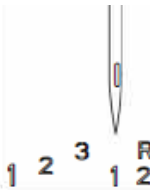

Programmes	Application	Needle position	Stitch length	Stitch width	Thread tension
Program 04 	For sewing together extremely durable fabrics such as upholstery covers and denim, both without overedge. May also be used for decorative effects.		3.0	5.0	<input type="text" value="3.0"/> _ _ _ _ <input type="text" value="1.5"/>
Program 05 	As flatlock seam for sewing stretchy fabrics together with decorative effect, or for overedging light fabrics.		2.0	5.5	_ <input type="text" value="1.5"/> _ <input type="text" value="6.0"/> _
Program 06 	As flatlock seam for sewing stretchy fabrics together with decorative effect, or for overedging medium fabrics.		2.0	5.5	<input type="text" value="1.5"/> _ _ _ <input type="text" value="6.0"/> _
Program 07 	For overedging light fabrics.		2.0	5.5	_ <input type="text" value="5.0"/> _ <input type="text" value="2.5"/> _
Program 08 	For overedging very fine fabrics and as decorative edge finish.		1.0	5.5	_ <input type="text" value="1.5"/> _ <input type="text" value="5.0"/> _

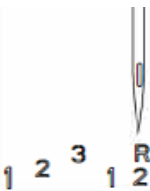

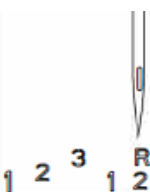

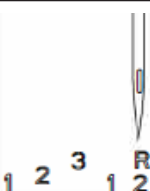

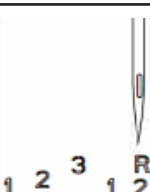



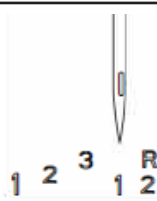

Programmes	Application	Needle position	Stitch length	Stitch width	Thread tension
 <p>Program 09</p>	For overedging very fine fabrics and as decorative edge finish.		1.0	5.5	- <input type="text" value="3.0"/> - <input type="text" value="3.0"/> -
 <p>Program 10</p>	For edging light, easily fraying fabrics.		2.0	5.5	- <input type="text" value="3.5"/> <input type="text" value="3.5"/> <input type="text" value="2.5"/> -
 <p>Program 11</p>	For overedging medium to heavy, easily fraying fabrics.		2.0	5.5	<input type="text" value="3.0"/> - <input type="text" value="1.0"/> <input type="text" value="1.0"/> -
 <p>Program 12</p>	For overedging heavy fabrics not prone to fraying		2.0	5.5	<input type="text" value="4.5"/> - <input type="text" value="0.5"/> <input type="text" value="7.5"/> -
 <p>Program 13</p>	As flatlock seam for sewing stretchy fabrics together with decorative effect and as decorative edge finish. Also for overedging medium weight fabrics.		1.0	5.5	- <input type="text" value="0.5"/> <input type="text" value="3.0"/> <input type="text" value="6.0"/> -



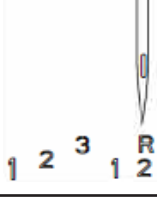

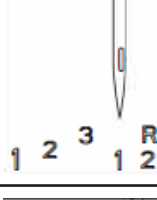

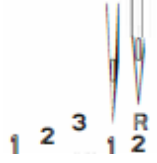



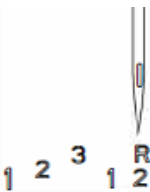

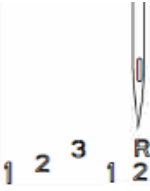
Programmes	Application	Needle position	Stitch length	Stitch width	Thread tension
<p>Program 14</p> 	<p>As flatlock seam for sewing stretchy fabrics together with decorative effect and as decorative edge finish. Also for overedging medium weight fabrics.</p>		2.0	5.5	<input type="text" value="0.5"/> _ <input type="text" value="2.5"/> <input type="text" value="7.0"/> _
<p>Program 15</p> 	<p>For sewing together and overedging light, highly stretchy fabrics.</p>		2.0	5.5	<input type="text" value="4.0"/> <input type="text" value="2.0"/> _ <input type="text" value="1.0"/> _
<p>Program 16</p> 	<p>For overedging light to medium fabrics and as decorative edge finish.</p>		1.0	5.5	_ <input type="text" value="2.5"/> <input type="text" value="3.5"/> <input type="text" value="2.0"/> _
<p>Program 17</p> 	<p>For overedging light to medium fabrics and as decorative edge finish.</p>		1.0	5.5	_ <input type="text" value="3.0"/> <input type="text" value="2.0"/> <input type="text" value="6.0"/> _
<p>Program 18</p> 	<p>For sewing together all fabrics with overedge, particularly stretch fabrics.</p>		2.5	5.5	<input type="text" value="3.5"/> <input type="text" value="2.0"/> <input type="text" value="2.0"/> <input type="text" value="1.5"/> _

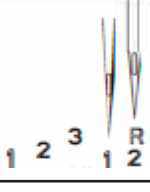
Programmes	Application	Needle position	Stitch length	Stitch width	Thread tension
Program 19  	For sewing together heavy fabrics with overedge.		2.5	8.0	<input type="text" value="3.0"/> <input type="text" value="0.5"/> <input type="text" value="4.0"/> <input type="text" value="1.5"/>
Program 20  	For sewing together heavy fabrics with overedge.		3.0	8.5	<input type="text" value="3.0"/> <input type="text" value="2.5"/> <input type="text" value="1.0"/> <input type="text" value="1.0"/> <input type="text" value="1.5"/>

Needle position	Stitch length	Stitch width	Differential	Upper Knife	Upper Looper	2-thread converter	Stitch width finger
	2.5	5.0	1.0	X			X
	3.0	5.0	1.0	X			X
	3.0	5.0	1.0	X			X
	3.0	5.0	1.0	X			X
	2.0	5.5	1.0	V			V

Needle position	Stitch length	Stitch width	Differential	Upper Knife	Upper Looper	2-thread converter	Stitch width finger
	2.0	5.5	1.0	V			V
	2.0	5.5	1.0	V			V
	1.0	5.5	1.0	V			X
	1.0	5.5	1.0	V			X
	2.0	5.5	1.0	V			V

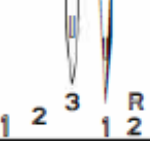
Needle position	Stitch length	Stitch width	Differential	Upper Knife	Upper Looper	2-thread converter	Stitch width finger
	3.0	5.5	1.0	V			V
	2.0	5.0	1.0	V			V
	2.0	5.5	1.0	V			V
	2.0	5.5	1.0	V			V
	2.0	5.5	1.0	V			V

Needle position	Stitch length	Stitch width	Differential	Upper Knife	Upper Looper	2-thread converter	Stitch width finger
	1.0	5.5	1.0	V			X
	1.0	5.5	1.0	V			X
	2.5	5.5	1.0	V			X
	2.5	8.0	1.0	V			X
	3.0	8.5	1.0	V			V



MEDIDAS DE PRECAUCIÓN

Lea este manual antes de utilizar la máquina.

No utilice la máquina a una temperatura ambiente superior a 45 ° C o inferior a 5 ° C, en habitaciones con mucha humedad o al aire libre, de lo contrario, es posible que la máquina no funcione correctamente. Para evitar la formación de condensación en los dispositivos electrónicos, no se recomienda encender la máquina tan pronto como se traslade del exterior a la habitación. Espere un momento hasta que la máquina alcance la temperatura ambiente. No se recomienda utilizar el dispositivo cuando la red eléctrica es inestable o en lugares donde hay un fuerte campo eléctrico o magnético, de lo contrario, la máquina no funcionará correctamente. La máquina debe instalarse sobre una superficie plana y estable, teniendo en cuenta la distancia requerida a los objetos estacionarios.

No deje caer la máquina, ya que esto puede provocar lesiones personales o daños a la máquina

AL OPERAR LA MÁQUINA

Tenga cuidado al trabajar, proteja sus manos para que no entren en el área de trabajo de las piezas móviles, especialmente en el área de las agujas. Para evitar descargas eléctricas o cortocircuitos, asegúrese de que todos los cables estén en buenas condiciones y no estén dañados (cortes, quemaduras, etc.), no entren en contacto con un ambiente húmedo o corrosivo. El cable de alimentación debe tener un buen contacto con la red. Al desconectar el cable de alimentación de la red, no tire del cable.

GUARDE ESTAS INSTRUCCIONES

Esta máquina está diseñada para uso doméstico únicamente.

Este dispositivo no está diseñado para que lo utilicen personas (incluidos niños) con capacidades físicas o mentales reducidas, o con falta de conocimientos y habilidades suficientes, a menos que estén supervisados o capacitados por personas responsables de su seguridad. Los niños deben ser supervisados para asegurarse de que no jueguen con este dispositivo.

Sujeto a las condiciones de funcionamiento y las reglas de almacenamiento de la máquina, la vida útil será de al menos 8 años.

CONOCIMIENTO DE LA MÀQUINA NOMBRES DE LAS PIEZAS

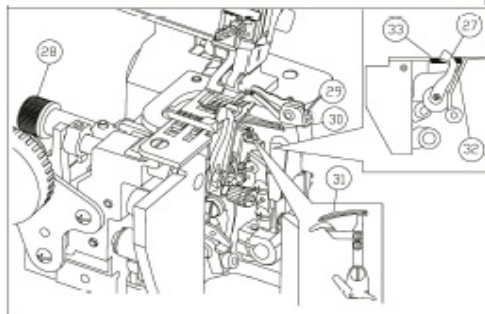
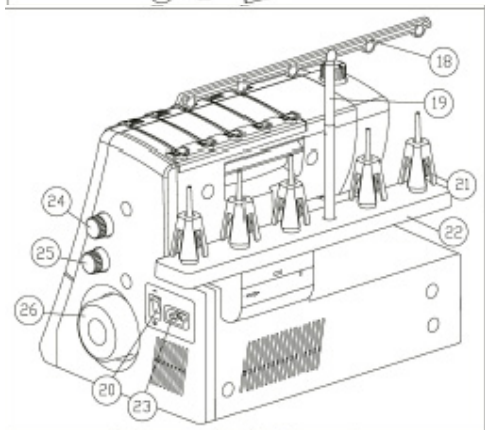
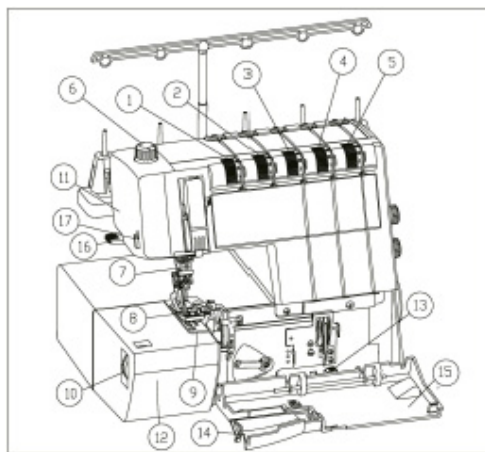

1. Selector de tensión del hilo de la aguja
2. Selector de tensión del hilo de la aguja
3. Selector de tensión del hilo del áncora superior
4. Selector de tensión del hilo del áncora superior
5. Regulador de la tensión del hilo del garfio de cadeneta.
6. Regulador de presión del prensatelas
7. Porta agujas
8. Pie estandar
9. Placa de agujas
10. Ajustador para el ancho del borde
11. Cubierta de la lampara
12. Cubierta de la plataforma izquierda
13. Palanca de liberación de la lanzadera
14. Inserto de la cubierta superior
15. Tapa de la lanzadera

16. Palanca de elevación del pie
17. Cuchilla cortahilos
18. Barra de guía del hilo
19. Varilla telescópica
20. Interruptor de encendido
21. Portacarretes
22. Portacarretes
23. Conector de pedal
24. Ajustador de longitud de puntada
25. Regulador para alimentación diferencial de tejido
26. Volante
27. Cuchilla superior
28. Mango de corte de la cuchilla superior
29. Looper derecho (superior)
30. Looper izquierdo (inferior)
31. Lanzadera para coser y cubrir
32. Dedo en forma de bucle
33. Cuchilla de fondo

*** Deslice la cubierta frontal (cubierta de bucle) hacia la derecha y hacia usted.**

ACCESORIOS INCLUIDOS

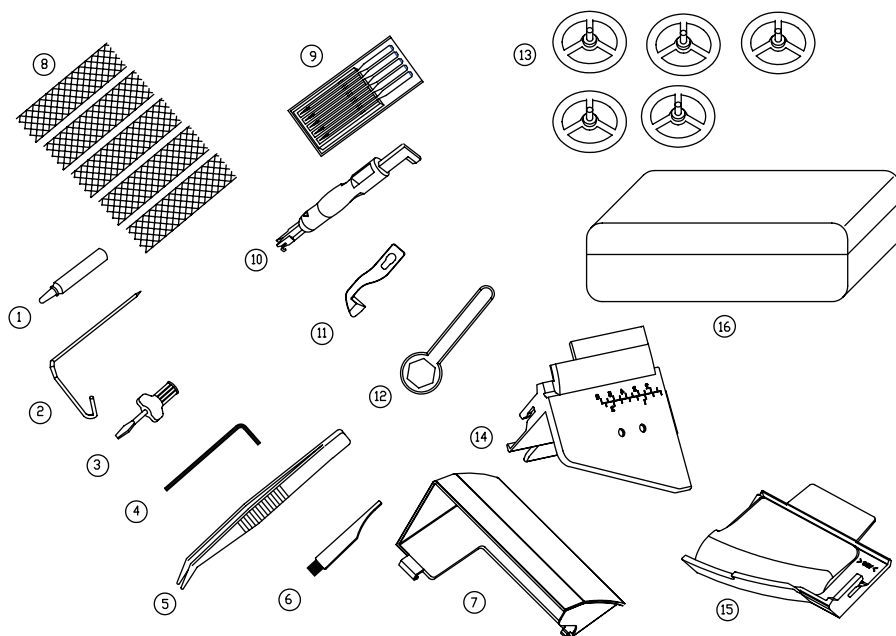

- | | |
|-------------------------------------|--|
| 1. Engrasador | 9. Un juego de agujas |
| 2. Regla guía | 10. Enhebrador de agujas manual |
| 3. Destornillador | 11. Cuchilla superior |
| 4. Cuchilla hexagonal | 12. Llave |
| 5. Pinzas | 13. Discos de retención de bobinas |
| 6. Cepillo para limpiar los restos | 14. Inserto de cubierta de lanzadera horizontal para tejido de koverlock |
| 7. Recipiente para recoger residuos | 15. Inserto superior de la tapa de la lanzadera |
| 8. Red para bobinas | 16. Caja de accesorios |

PREPARACIÓN PARA COSER

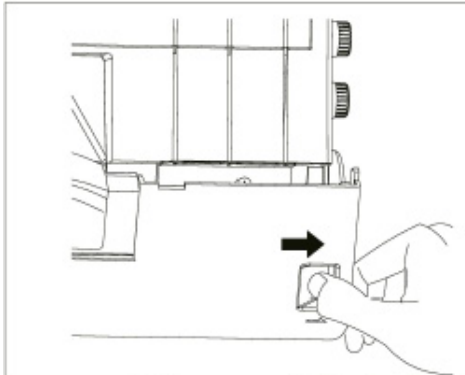

Cubierta de la lanzadera

Deslice la tapa de la lanzadera hacia la derecha y luego tire de ella hacia usted.

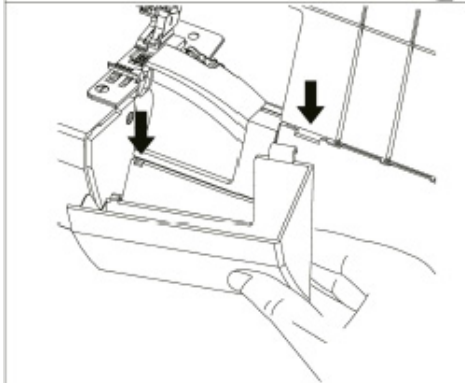

Contenedor de recogida de residuos

Presione hacia abajo en la parte inferior del recipiente hasta que el pestillo inferior encaje en la ranura.

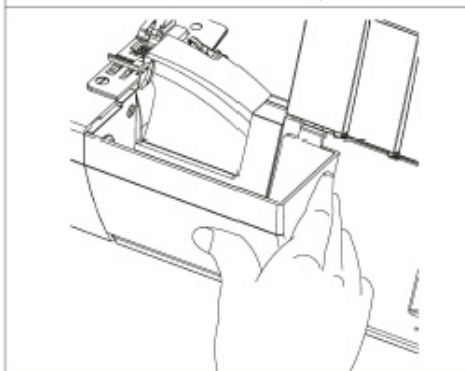

Para retirar el contenedor, debe repetir esta acción.

GUIAHILOS TELESCÓPICO / SOPORTES DE CONOS / PORTABOBINAS

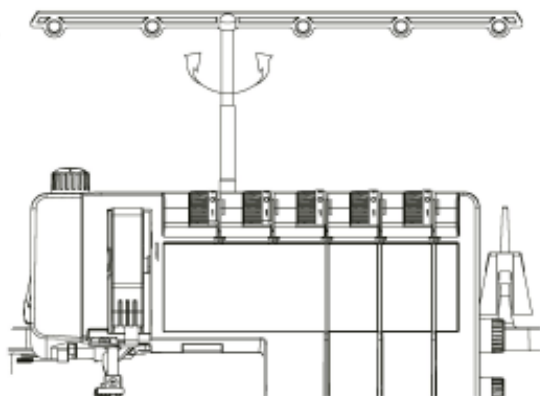

GUÍA DE HILO TELESCÓPICO

Levante la guía del hilo telescópico a su altura máxima.

Para un avance óptimo del hilo, gire la guía del hilo hacia afuera hasta que encaje en su lugar.

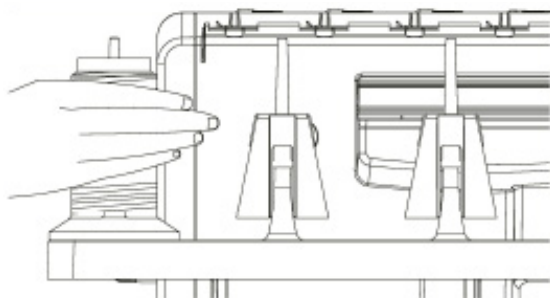

Portabobinas

Para bobinas grandes (5.000-10.000 mm), utilice los portabobinas y los pines de la bobina. Cuando se utilizan hilos sintéticos, los discos-almohadillas de polipropileno mantienen los hilos fuera de las bobinas. Los portabobinas se utilizan para fijar firmemente las bobinas en las varillas.

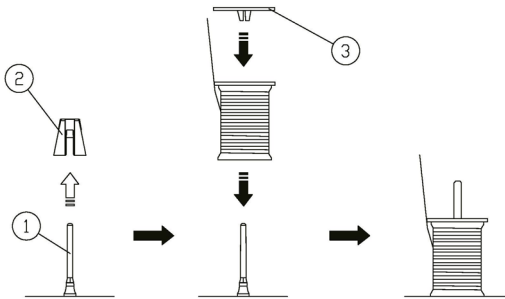
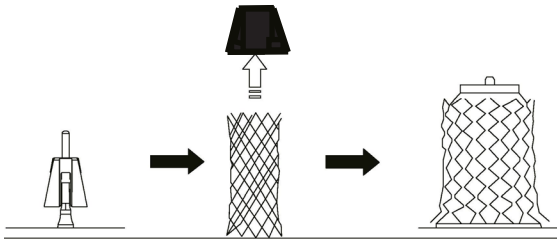

- 1) Pin para bobina y bobina
- 2) Portabobinas
- 3) soporte de bobina

Retenedores de carrete

Si el hilo rebota en el carrete mientras enhebra y / o cose, deslice la red sobre el carrete. Cuando utilice carretes pequeños, retire los portabobinas. Deslice los retenedores del carrete sobre el carrete desde la parte superior.

LEVANTAR EL PRENSATELAS Y LAS AGUJAS

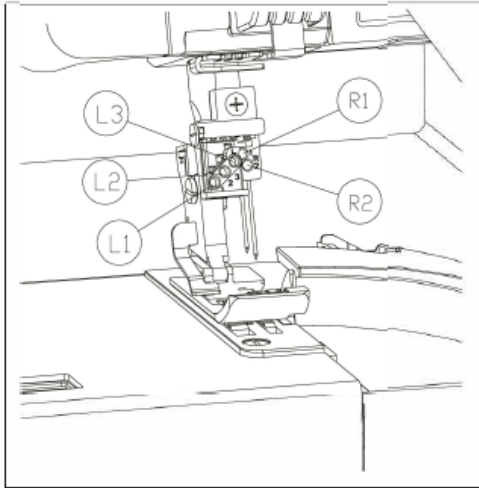

Puede coser eligiendo entre 5 posiciones de aguja. Puede coser con 3 agujas al mismo tiempo.

△ NOTA:

Si se insertan agujas en R1 y R2, la aguja izquierda está más alta que la derecha.

Cuando se utilizan agujas L2 y L3, la aguja izquierda se inserta más abajo que la derecha. Si se utilizan L1 y L3, la aguja izquierda también está más baja que la derecha. Si se utilizan las agujas L1, L2 y L3, la aguja izquierda está en la posición más baja.

El prensatelas se puede subir / bajar utilizando la palanca elevadora del prensatelas.

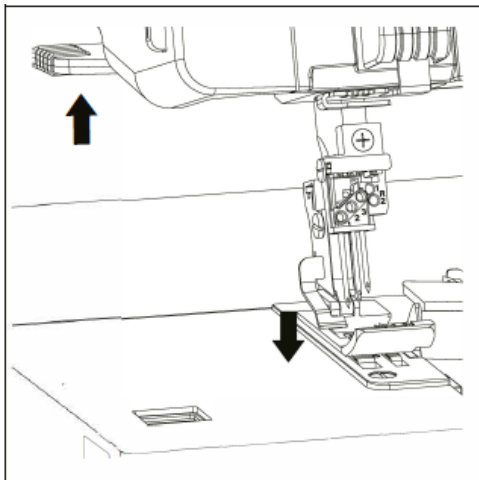

△ NOTA:

El prensatelas debe bajarse mientras se cose.

REEMPLAZO DE LA AGUJA

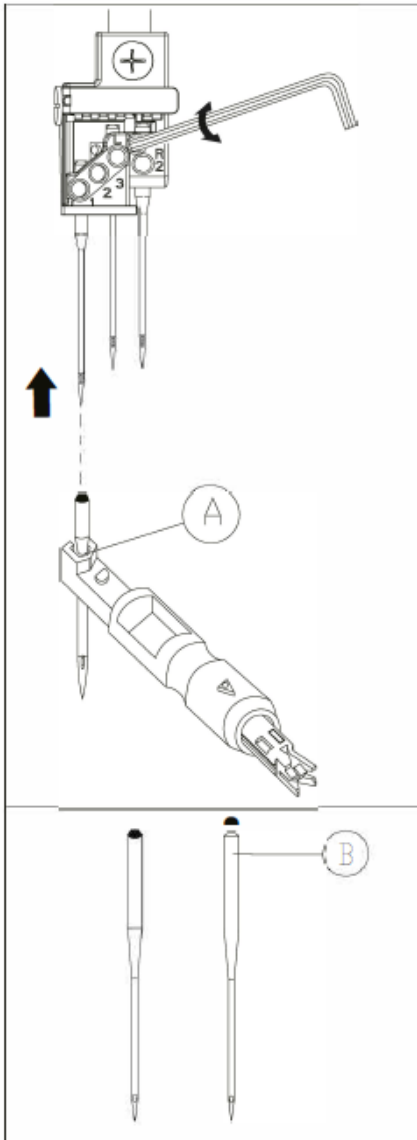

⚠ ¡DESCONECTE LA MÁQUINA DE LA ENERGÍA!

Retirar la aguja: baje el prensatelas y suba las agujas a la posición superior.

Inserte la aguja completamente en el porta agujas especial en la caja de accesorios. Afloje pero no retire el tornillo con la llave hexagonal y tire de la aguja hacia abajo.

Insertar la aguja: Inserte la aguja en el orificio A del porta agujas especial con el corte B alejándolo de usted. Inserte la aguja en la base de la barra de agujas todo lo que pueda y apriete con una llave hexagonal. Retire el portaagujas especial

Sistema de agujas	Needle Size	Tipo de tejido
Organ EL x 75 CF	11-14 (75-90)	Tejidos de ligeros a medianos como seda, algodón,
SINGER 2020	11-14	tejidos elásticos y de punto, denim, etc.

CONEXIÓN ELÉCTRICA

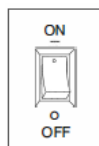
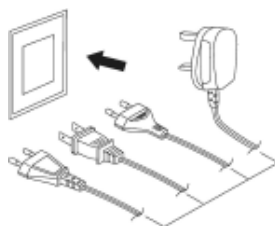
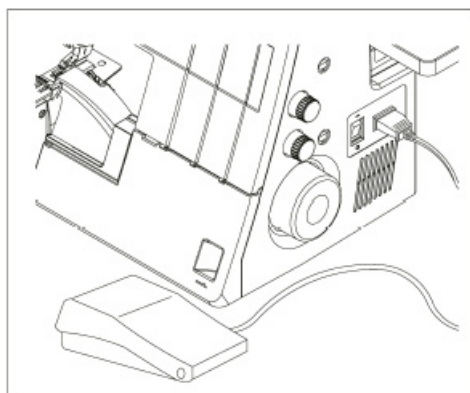

Antes de enchufar el cable de alimentación a la red, asegúrese de que el voltaje indicado en la máquina coincida con el voltaje de la red.

Coloque la máquina sobre una superficie estable.

1. Inserte el enchufe de la máquina en el enchufe.
2. Inserte el enchufe de alimentación en una toma de corriente.
3. Encienda la energía.
4. La lámpara de iluminación del área de trabajo se encenderá cuando se encienda la unidad.

Para apagar la alimentación, gire el interruptor a la posición «0», luego retire el enchufe del conector.

EMPEZAR A COSER

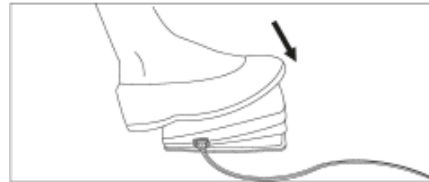

Corte la energía e inserte el enchufe de la máquina en el conector de la máquina. Inserte el enchufe de alimentación en la toma

PEDAL

La velocidad de costura se regula con el pedal. Cuanto más pise el pedal, más rápido funcionará la máquina. Levante el prensatelas, pise el control de pie y practique el trabajo a diferentes velocidades.



- **POR SU SEGURIDAD:!**
Mire siempre el área de costura mientras cose. No toque ninguna parte móvil de la máquina, como la guía del hilo, los garfios, el volante, la aguja o las cuchillas.
- Siempre desconecte la energía si:
 - deja la maquina desatendida
 - cambia o agrega alguna parte
 - enhebra o limpia la máquina
- No coloque nada sobre el pedal, especialmente cuando la máquina esté en funcionamiento.

AJUSTE DE LA PRESIÓN DEL PRENSATELAS

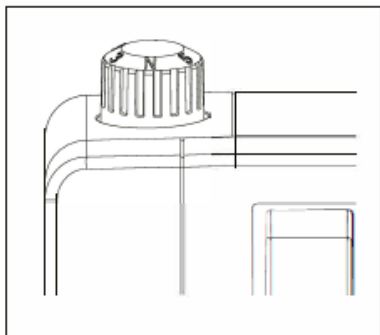

Para la costura normal, no es necesario cambiar la presión del pie sobre la tela.

Al coser telas diferentes, gire el tornillo de ajuste de acuerdo con la tela. En este caso, puede elegir entre seis posiciones. Prensatelas estándar «N».

△ **NOTA:**

Baje el prensatelas antes de girar la perilla de ajuste de presión del prensatelas. Esto hace que la perilla sea más fácil de girar.

ENHEBRAR LAS GUÍAS DEL HILO

ATENCIÓN:

Antes de enhebrar, apague la máquina y desenchúfela. Enhebre la máquina en el siguiente orden:

- 1) Hilo del garfio izquierdo
- 2) Hilo del garfio derecho
- 3) hilo de la aguja izquierda
- 4) Hilo de la aguja derecha
Suba la palanca del pie prensatela.

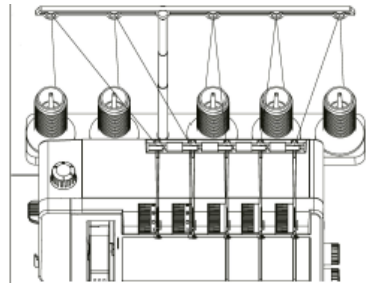

Secuencia de subprocesos

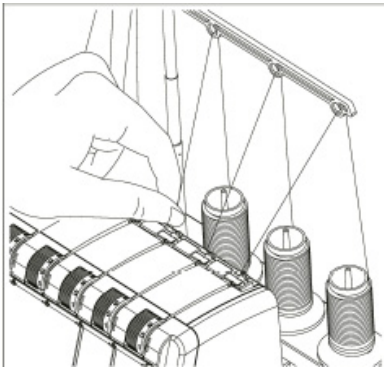

△ NOTA:

Enhebre en una secuencia de 1 a 5.

4 5 1 2 3

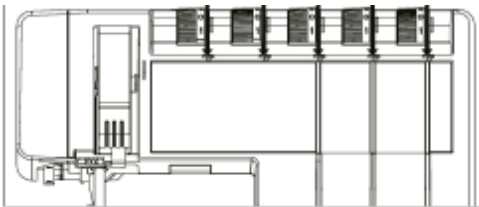

NOTA:

Levante siempre el prensatelas antes de enhebrar la máquina.

ENHEBRADO DE LA LANZADERA DERECHA (SUPERIOR)

Gire el volante hacia usted hasta que la lanzadera se eleve a su posición más alta.

A - garfio superior

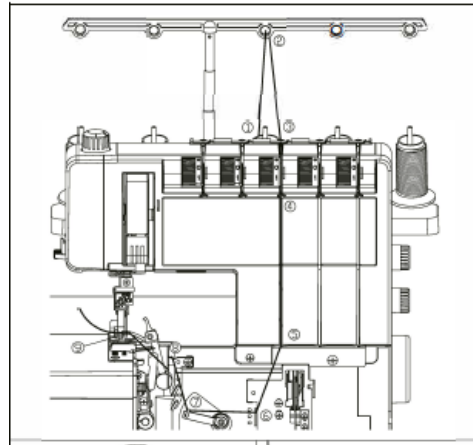

Pase el hilo por las guías del hilo del paso 1 al paso 7.

Pase el hilo por la guía del hilo 8 desde arriba y tire de él hacia abajo y hacia la izquierda hasta que entre en la horquilla guía.

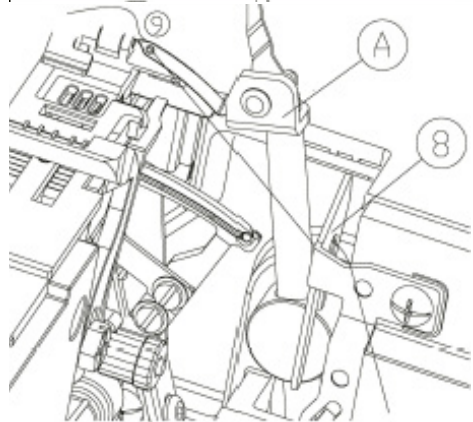

Tire hacia el ojo de la lanzadera 9. Saque 10 cm de hilo y páselo por debajo del prensatelas.

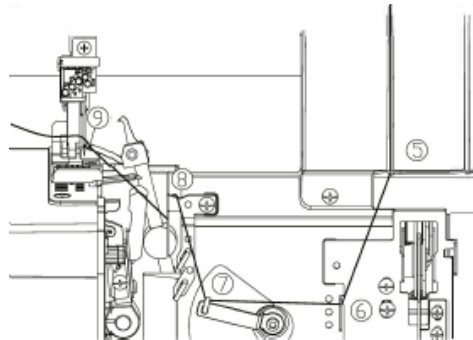

ENHEBRADO DE LA LANZADERA IZQUIERDA (INFERIOR)

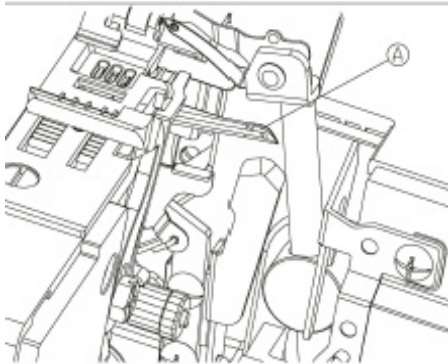

Gire el volante hacia usted hasta que el garfio esté en la posición extrema derecha.

A - garfio inferior

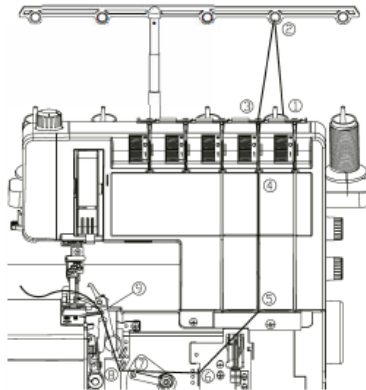

Pase el hilo a través de la guía del hilo desde el paso 1 al 9.

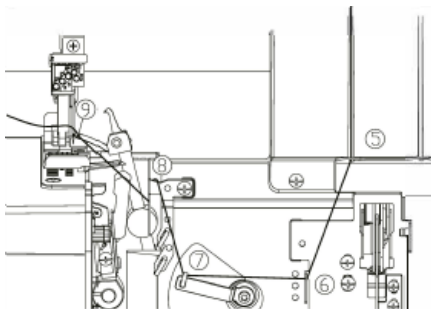

Baje la palanca (a) y coloque el hilo en la guía del hilo (b). Enhebre el hilo lejos de usted en el ojal (c) en el extremo derecho del garfio.

Sacar 10 cm de hilo y pasarlo por debajo del pie.

ENHEBRAR EL BUCLEADOR DE COSTURA KOVERLOCK (PUNTADAS DE COSTURA Y RECUBRIMIENTO)

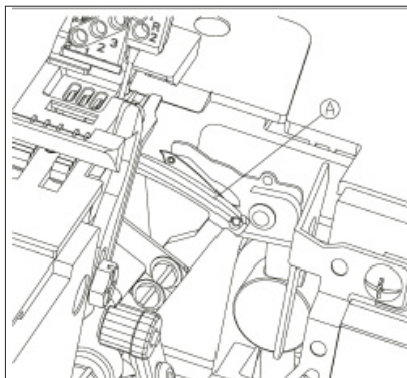

Gire el volante hasta que la lanzadera esté en la posición más a la derecha.

A - gancho de costura

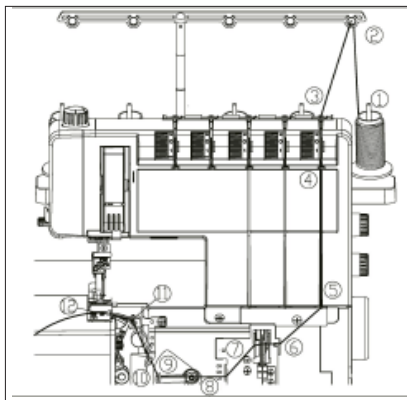

Pase el hilo a través de la guía del hilo desde el paso 1 al 12

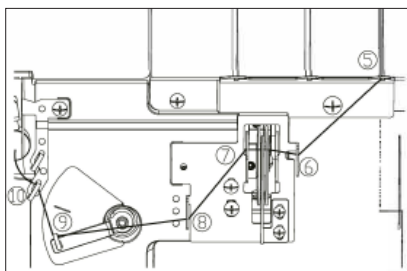

Nota:

Al enhebrar los puntos 6 y 7, el hilo simplemente se coloca en la parte superior y no se inserta.

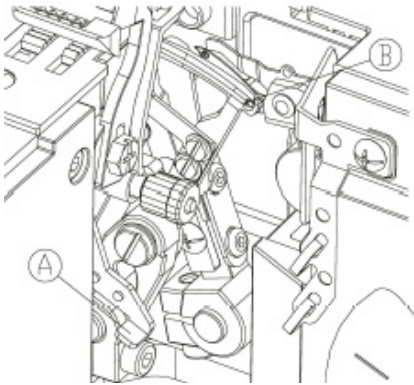

Levante la palanca (A) y enhebre el corte (B).

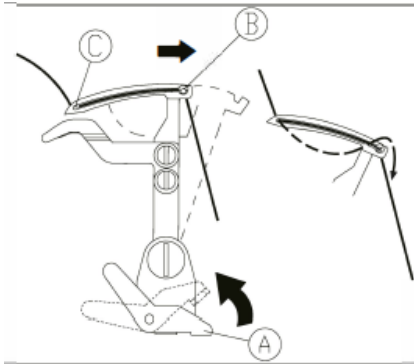

△ NOTA:

La palanca volverá a su posición original tan pronto como comience a coser.

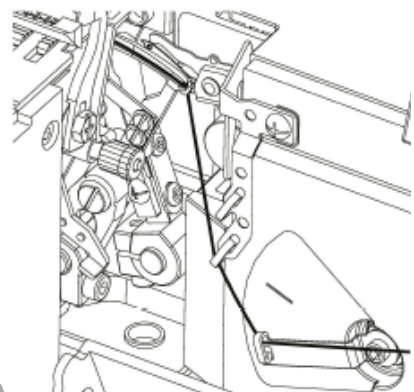

Pase el hilo a través del ojo del garfio (C) lejos de usted.

Saque 10 cm de hilo y páselo por debajo del prensatelas.

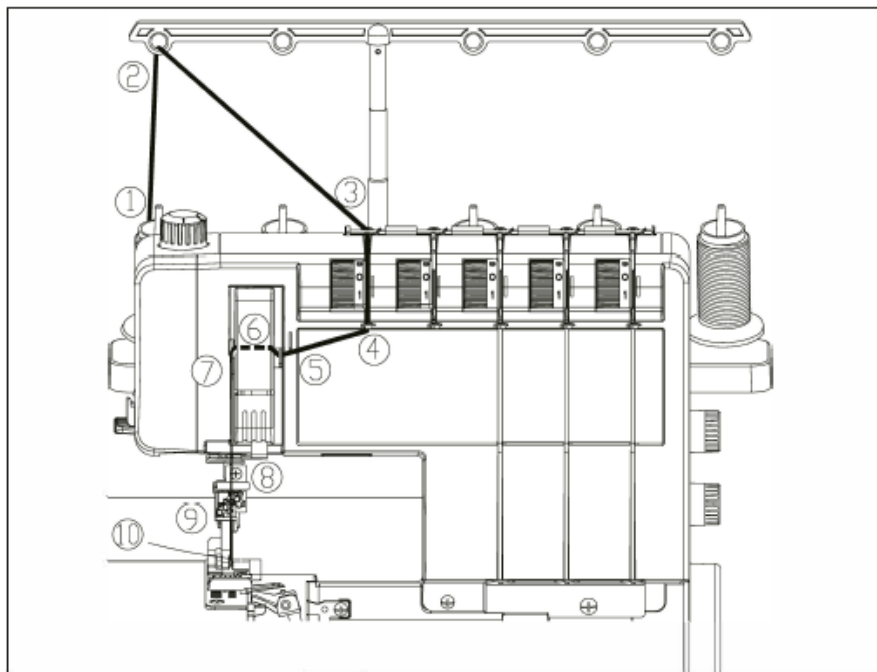
ENHEBRADO DE AGUJAS

Enhebre los hilos del paso 1 al paso 10. El hilo debe pasar por la muesca inferior de la guía del hilo 5 Saque 10 cm de hilo y páselo por debajo del prensatelas.

Si cose con las agujas L1, L2 o L3, debe utilizar la guía del hilo A.

(A) - guíahilos A

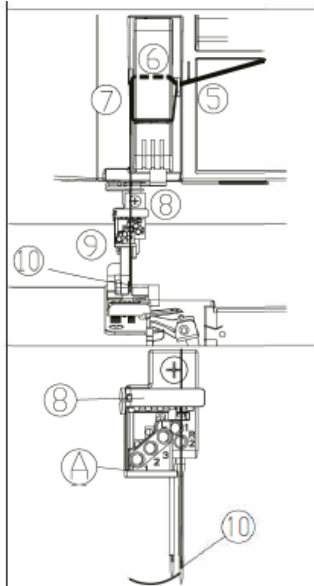
EXCEPCIÓN:

Enhebre la aguja L3 al coser con la puntada overlock de 5 hilos. (Programa 20) y al coser con puntada overlock de 4 hilos (Programa 19) y Puntada de costura de 2 hilos (Programa 04).

Enhebre el hilo en el orden del punto 1 al punto 10.

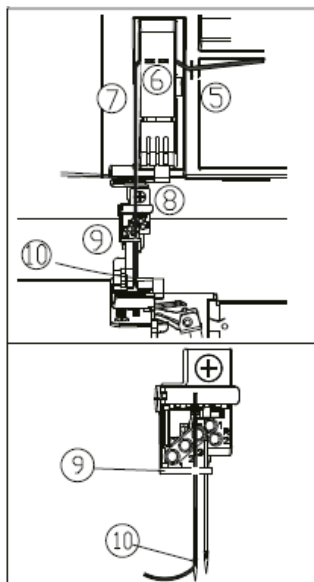
△ NOTA:

Al enhebrar la lanzadera (Programa 04) debe enhebrar el tensor verde.

El hilo debe pasar por la muesca superior de la guía del hilo 6. Saque 10 cm de hilo y páselo por debajo del prensatelas.

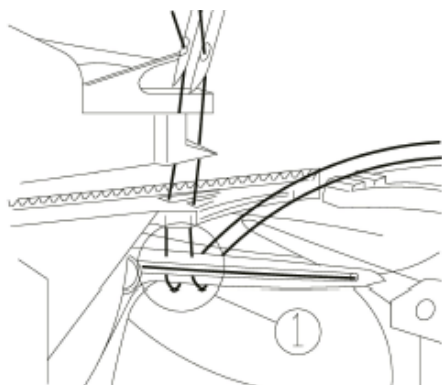

Importante al enhebrar agujas:

Enhebre siempre las agujas al final para que no queden atrapadas en los hilos del garfio, como se muestra en la fig.

- 1) Pero debe estar encima de los hilos del garfio, como en la fig.
- 2) De lo contrario puede producirse la rotura del hilo. Si los hilos de la lanzadera están rotos, debe quitarlos de las agujas, enhebrar las garras y luego enhebrar las agujas.

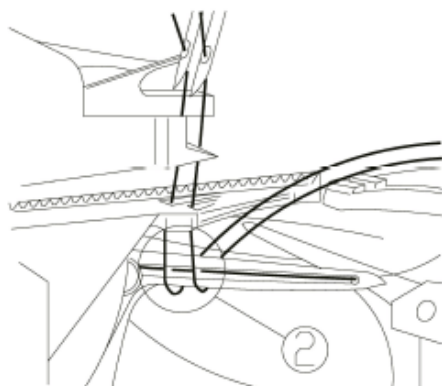

ENHEBRADOR DE AGUJAS MANUAL

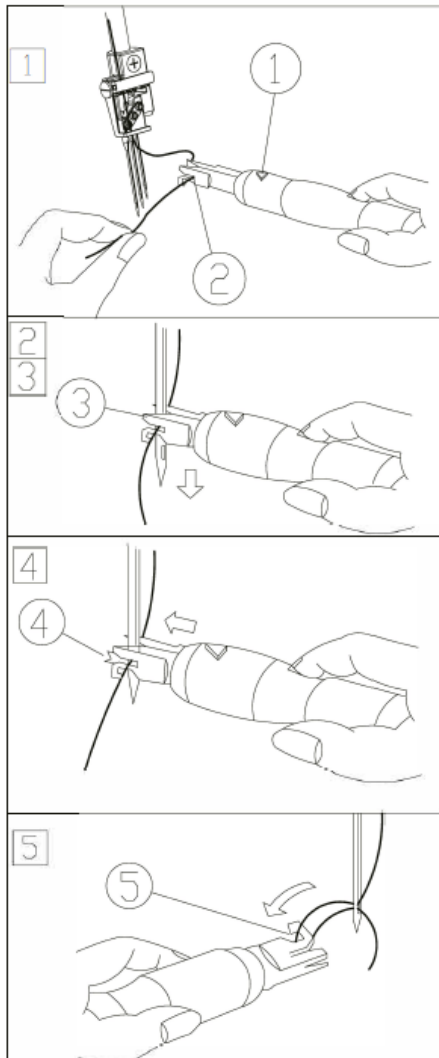

Apague en el interruptor de encendido

Suba las agujas a su posición más alta y baje el prensatelas.

Inserte el hilo de derecha a izquierda en la muesca del enhebrador de aguja A.

Una de las dos marcas triangulares debe mirar hacia arriba.

Coloque el enhebrador frente a la ranura frontal de la aguja, tóquelo, bájelo hasta el ojo de la aguja y empuje suavemente el enhebrador a través del ojo. Un pequeño alfiler de metal pasará por el ojo de la aguja y automáticamente la enhebrará.

NOTA:

Si presiona demasiado, el pequeño montante de metal puede doblarse. Y el enhebrador de agujas fallará.

Ahora use el gancho 5 para pasar el lazo a través del ojal

DIAGRAMA DE ENHEBRADO GENERAL PARA TODO TIPO DE PROGRAMAS

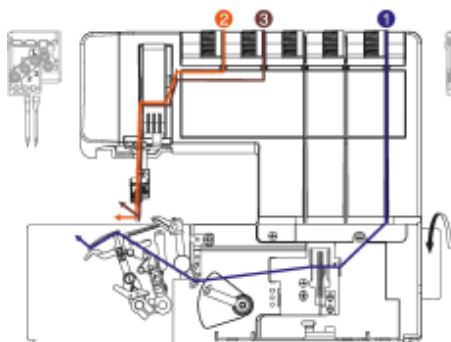

Programa 01 -
Puntada de cobertura de 2 agujas

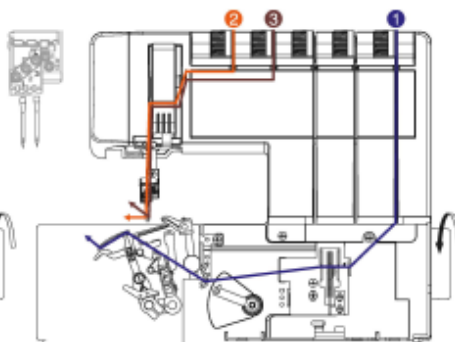

Programa 02 -
Puntada de cobertura, ancha (L1 / L3).

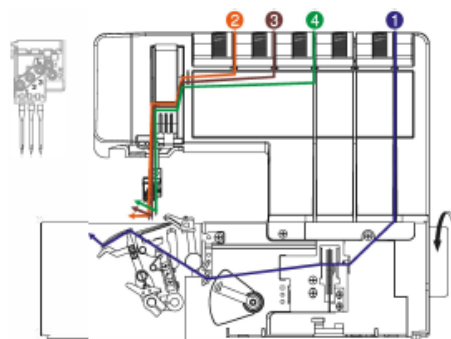

Programa 03 -
Costura estrecha (L2 / L3).
Puntada de cobertura de 3 agujas

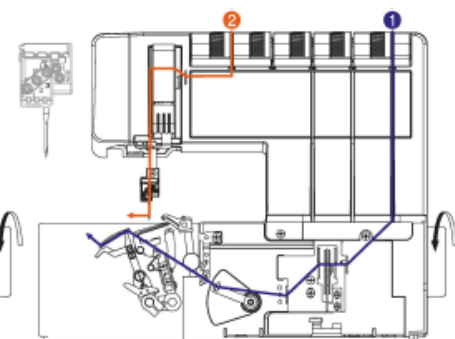

Puntada 04 - - Puntada de costura (L3)
(puntada de cadeneta de una aguja).

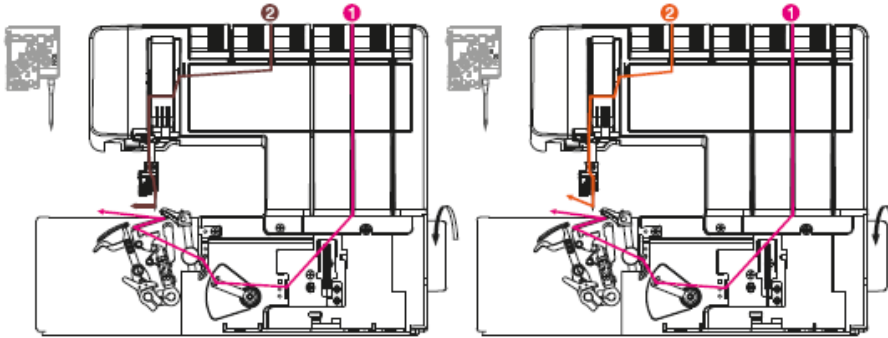

Programa 05 - Puntada FlatLock de 2 hilos, estrecha (R2)

Programa 06 ' - ' -
Puntada FlatLock de 2 hilos, ancha (R1)

Programa 07 - Sobrehilado de 2 hilos, estrecho (R2)

Programa 08- Dobladillo plano de 2 hilos (R2)

Programa 09- Plegado de 2 hilos. Dobladillo enrollado (R2)

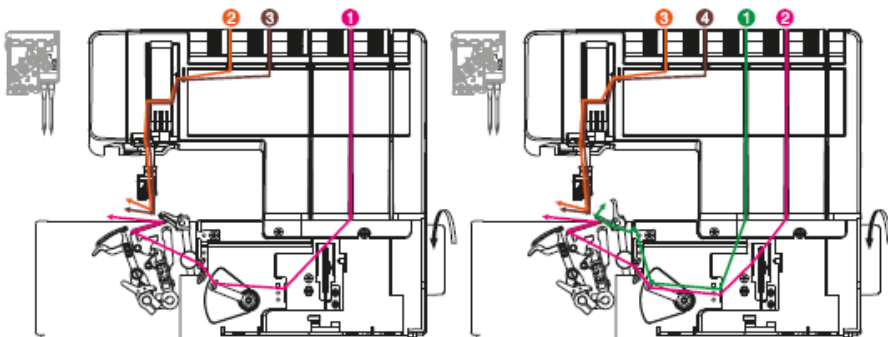

Programa 10 - Puntada overlock de 3 hilos, estrecha (R2)

Programa 11- Sobrehilado de 4 hilos (R1/ R2)

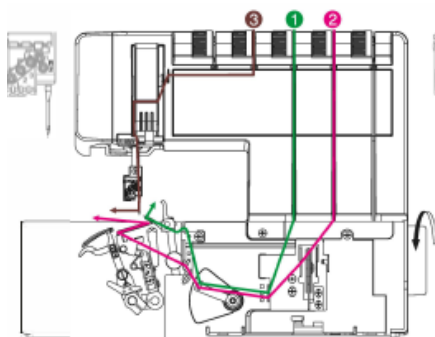

Puntada 12 - Sobrehilado de 3 hilos, estrecho (R1)

Programa 15 - Flatlock de 3 hilos, estrecho (R2)

Programa 17 - Doblado de rodillo de 3 hilos (R2) 3,0 2,0 6,0

Programa 18 - Plegado de 3 hilos. Doblado enrollado (R2)

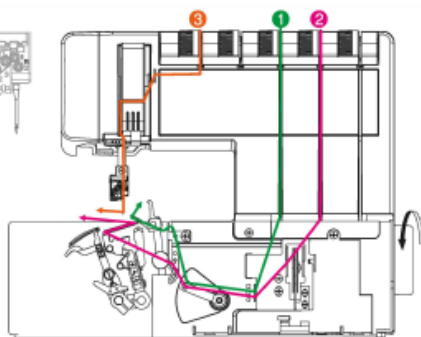

Programa 13 - Puntada FlatLock de 2 hilos, estrecha (R2) 2,0 3,0 6,0

Programa 14 - Sobrehilado de 3 hilos, ancho (R1)

Programa 16 - Puntada de rodillo plano de 3 hilos (R2) 3,0 4,0 3,0

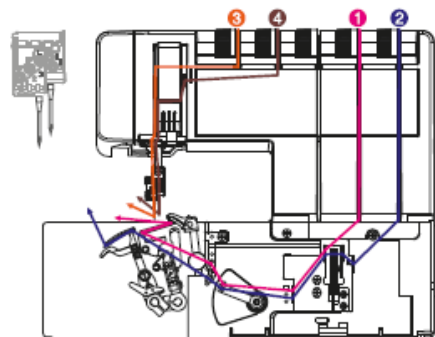

Programa 19 - Puntada de seguridad de 4 hilos, ancha (LÇ/R1)

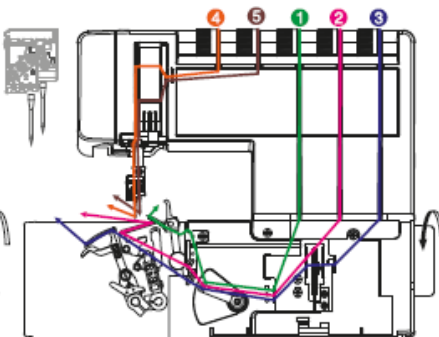

Programa 20 - Puntada de seguridad de 5 hilos, ancha (LÇ/ R1)

CORTADOR DE HILO INCORPORADO

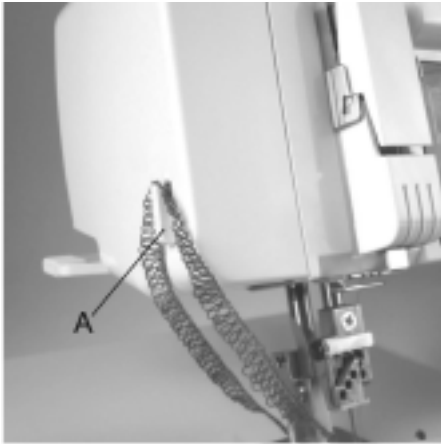

Al final de la costura, deje una cadena de hilos de 15-20 cm de largo, tire de ella hacia la cuchilla cortahilos. Esto cortará el hilo.

A - cortador de hilo.



Coloque la tela directamente frente a las agujas. Si es necesario, utilice unas tijeras para cortar 3 cm a lo largo del borde de la tela.

Baje el prensatelas y comience a coser. La puntada se forma automáticamente a lo largo del corte.

△ NOTA:

Este método es adecuado para coser cubiertas.



CONTENEDOR DE RECOGIDA DE RESIDUOS

Coloque el contenedor de residuos en la tapa del garfio delantero
Caerán trozos de tela en él.

DESCONECTAR LA CUCHILLA SUPERIOR

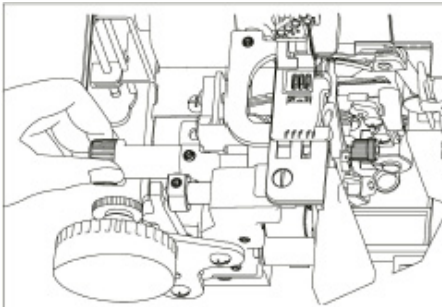

⚠ ¡DESCONECTE LA ENERGÍA DE LA MÁQUINA!

Retire el contenedor de residuos, abra la tapa del garfio delantero y la tapa de la plataforma izquierda.

Levante la cuchilla superior a la posición más alta girando el volante.

Ahora empuje el mango de liberación de la cuchilla superior completamente hacia la derecha.
A - cuchilla superior

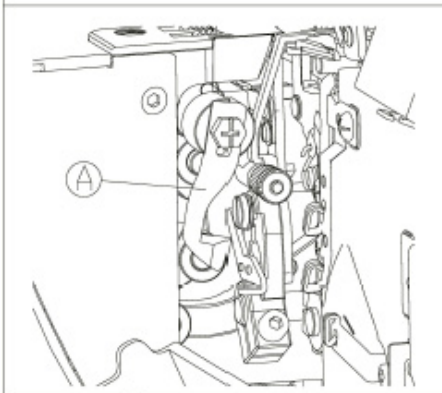

Gire el mango hacia usted hasta que la cuchilla superior esté hacia abajo. La cuchilla está desactivada.

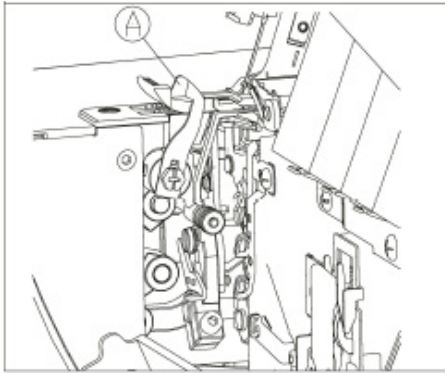

Encendido de la cuchilla superior.
Empuje la perilla completamente hacia la derecha y gírela hacia afuera hasta que haga clic. La cuchilla volverá a su posición de trabajo.

Cierre la tapa de la lanzadera y la tapa de la plataforma izquierda. Vuelva a colocar la caja del cortador.

DESHABILITAR EL ESPARCIDOR

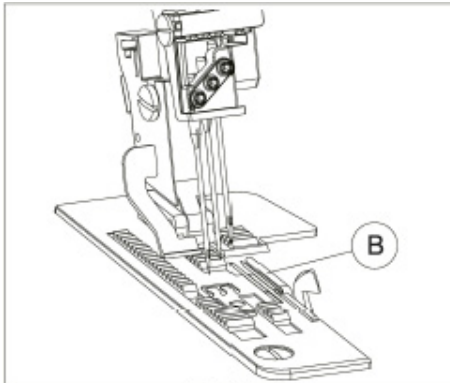

Para puntadas overlock estándar.

Para coser con todas las puntadas overlock estándar (Programas 02, 04), el esparcidor volverá a su posición original.

A - perilla para desenganchar el esparcidor.

B - esparcidor.

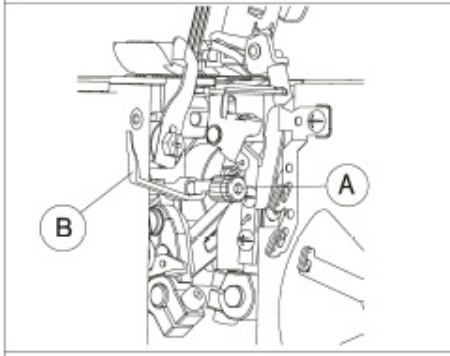

Para puntadas con rodillo.

Retire el contenedor de residuos y abra la tapa del garfio frontal. Tire de la manija A hacia la derecha y baje el esparcidor hasta su posición inoperante girando la manija hacia usted.

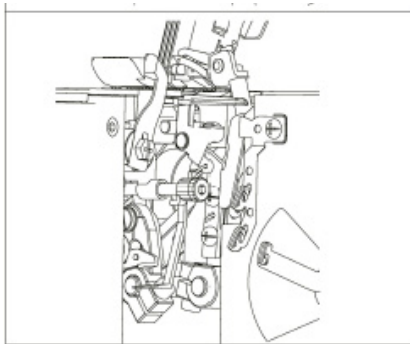

Con este ajuste, puede coser todas las puntadas enrolladas, así como las puntadas de cobertura y las puntadas decorativas. (Programas 02, 04)

CONVERTIDOR DE BUCLEADOR DERECHO (SUPERIOR)



Inclusión de un convertidor de 2 hilos.

Gire el volante hasta que la lanzadera derecha (superior) se eleve a la posición más alta.

Baje el convertidor e inserte su gancho en el ojo de la lanzadera.

A - convertidor de 2 hilos

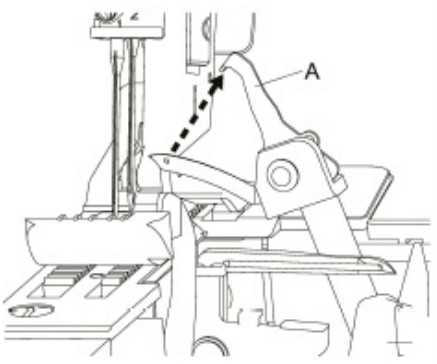

Desconexión del convertidor de 2 hilos.

Gire el volante hasta que la lanzadera derecha (superior) se eleve a la posición más alta. Quite el gancho del convertidor del ojo de la lanzadera y levante el convertidor a su posición original (arriba a la derecha).

DESHABILITAR EL BUCLEADOR DERECHO (SUPERIOR)

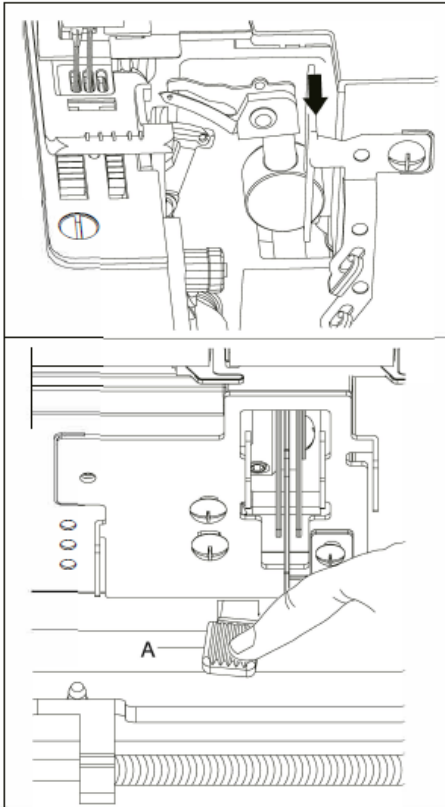

Para coser puntadas de cobertura y puntadas de costura, desenganche la presilla derecha (superior) con la palanca de liberación. Retire el contenedor de desechos y abra la tapa frontal del bucle.

Gire el volante hasta que el garfio baje a su posición más baja.

A - palanca para desenganchar la lanzadera derecha (superior).

Empuje la palanca de liberación del garfio hacia abajo y deslícela hacia la izquierda. Gire el volante para asegurarse de que la lanzadera no se mueva.

Para activar el garfio superior derecho, presione la palanca de liberación del garfio y vuelva a colocarlo en su posición original. Gire el volante hasta que la

lanzadera comience a moverse hacia arriba con un clic característico.

Cierre la tapa frontal y vuelva a colocar el contenedor de residuos.

AJUSTE DE LA LONGITUD DE LA PUNTADA Y EL AVANCE DIFERENCIAL

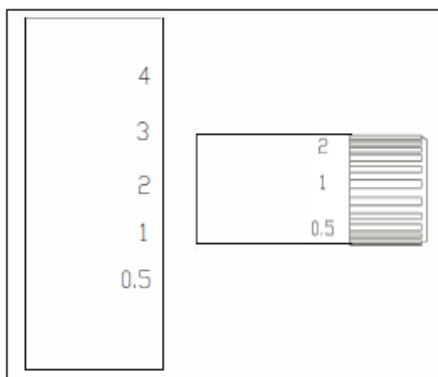

Gire el dial de longitud de puntada para seleccionar la longitud de puntada deseada.

La longitud de la puntada se puede configurar de 0,5 a 4.

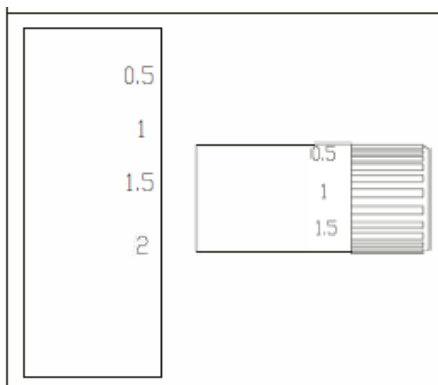

Gire la perilla de alimentación diferencial para seleccionar la proporción deseada.

La alimentación diferencial se puede configurar de 0,5 a 2.

REEMPLAZO DEL INSERTO SUPERIOR DE LA TAPA DE LA LANZADERA

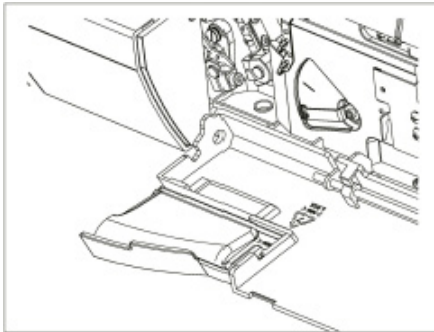

Retire el contenedor de residuos y abra la tapa de la lanzadera. Tire del inserto de la cubierta de la lanzadera hacia arriba y hacia afuera.

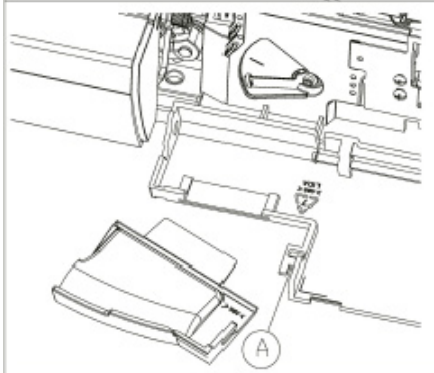

Para insertar la plataforma de costura de recubrimiento horizontal en la cubierta frontal, colóquela debajo del pestillo A. Y presione a lo largo de las guías de la cubierta frontal.

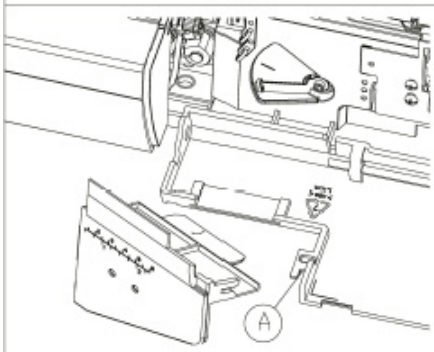

△ NOTA:

La plataforma horizontal está marcada con riesgos medibles. Los riesgos superiores están en centímetros y los inferiores en pulgadas.

AJUSTE DEL ANCHO DE CORTE DE LA TELA

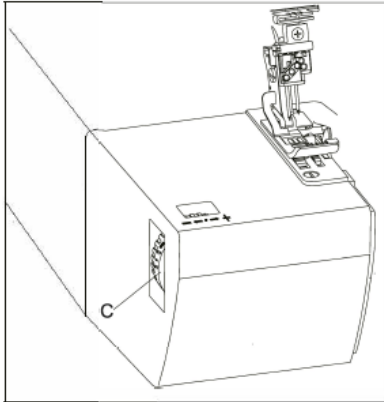

Gire la perilla de ajuste del ancho de corte para seleccionar entre 3,5 y 6,0 mm.

Nota:

La puntada de costura de cadena se cose en valores de 0,5 a 9.

C - botón para ajustar el ancho del recorte de la tela.



Figura A. Y, si los bucles sobresalen más allá del corte de la tela, gire la perilla del regulador hacia arriba para mover el cuchillo hacia la derecha.



Figura B, si los bucles aprietan el corte de la tela, gire la perilla de ajuste hacia abajo para mover la cuchilla hacia la izquierda.

△ NOTA:

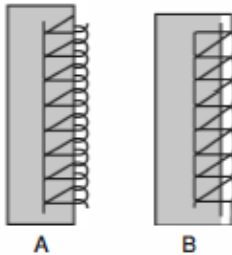
El ancho de corte ajustado de 4,8 mm a 5,0 mm solo es importante para la aguja R1. Este valor disminuye en 2 mm cuando se usa la aguja R2.

INSTALACIÓN DE LA VALLA

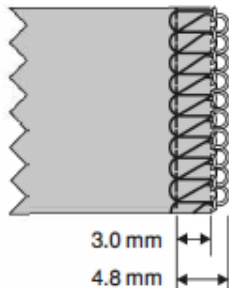
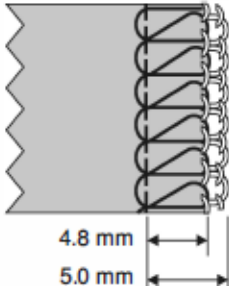
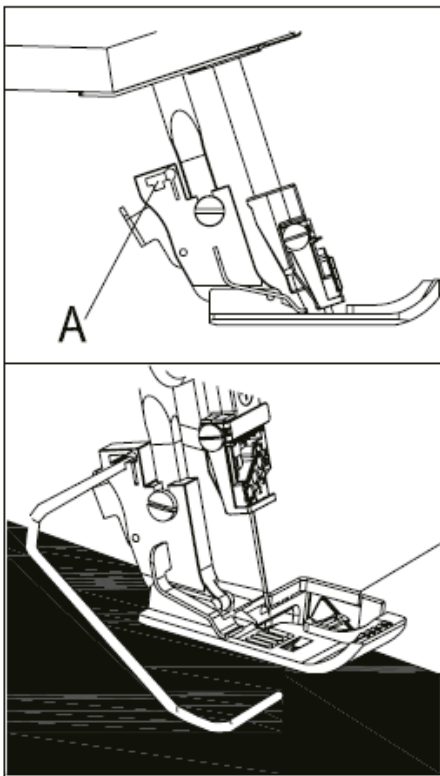
! ¡DESCONECTE LA MAQUINA DE LA ENERGIA!

Inserte la guía de costura y acolchado suministrada de izquierda a derecha en la ranura A del soporte del pie.

Puede ajustar la regla a su gusto deslizándola hacia la derecha / izquierda en el soporte del pie.

Puede utilizar estos ajustes para todas las puntadas con rodillo.

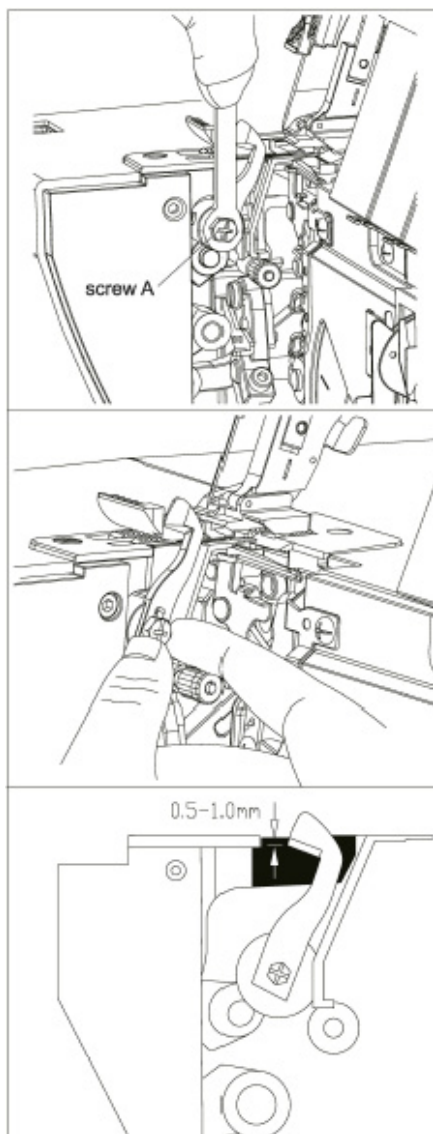
REEMPLAZO DE LA CUCHILLA SUPERIOR



¡DESCONECTE LA MÁQUINA DE LA ENERGÍA!

Quitar la cuchilla.

Establezca el ajustador de ancho de recorte en 3,5 mm. Afloje el tornillo A con la llave de accesorios y retire la cuchilla superior.

Instalar la cuchilla.

Instale la cuchilla superior y apriete ligeramente el tornillo A. Gire el volante hasta que la cuchilla superior baje a su posición más inferior.

En su posición hacia abajo, el extremo delantero de la cuchilla superior debe estar 1 mm por debajo de la cuchilla inferior cuando haya instalado correctamente la cuchilla superior. Apriete el tornillo A completamente.

CUIDADO DE LA MAQUINA

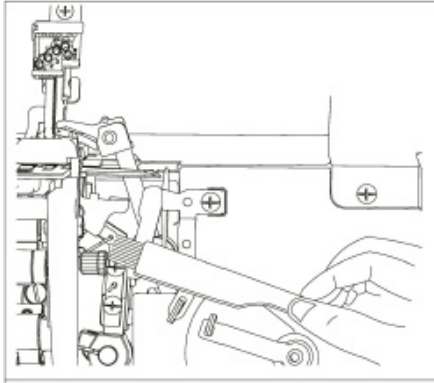

Retire el recipiente para recoger restos de tejido. Abra la tapa superior de la lanzadera y la tapa de la plataforma izquierda. Desconecte la cuchilla superior. Retire el prensatelas y la placa de la aguja. Utilice un cepillo del kit de accesorios para eliminar todo el polvo y el vellón de las cuchillas superior e inferior, las rejillas de engranajes y el área de la lanzadera.



¡DESCONECTE LA MAQUINA DE LA ENERGIA!

Limpiar la máquina

Retire el recipiente para recoger restos de tejido. Abra la tapa superior de la lanzadera y la tapa de la plataforma izquierda. Desconecte la cuchilla superior. Retire el prensatelas y la placa de la aguja. Utilice un cepillo del

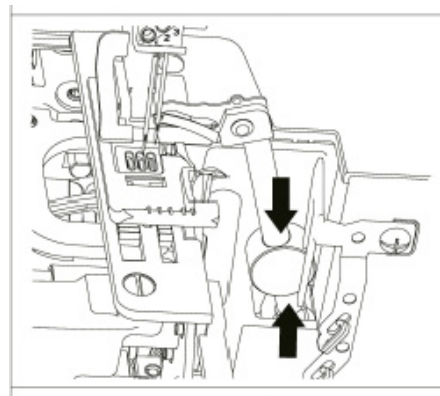

Lubricación de la máquina.

Coloque la lanzadera derecha (superior) en la posición más alta girando el volante. Después de cada limpieza de la máquina, lubrique el área indicada por las flechas en la ilustración. 1-2 gotas de aceite son suficientes.

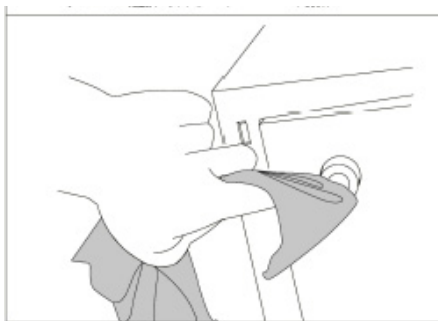
**Limpieza de las patas de goma.**

Limpie las patas de goma de vez en cuando con alcohol metílico. Esto eliminará la vibración de la máquina mientras cose.

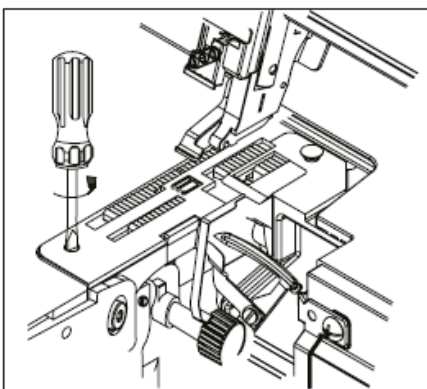
**Retirar la placa de aguja.**

Retire las agujas, retire el prensatelas y el soporte del prensatelas.

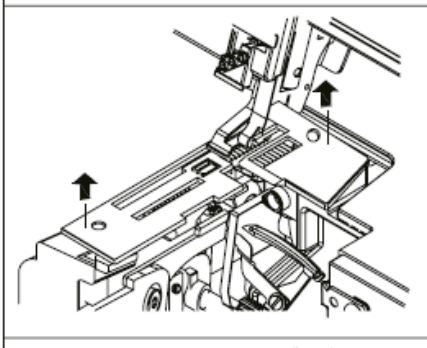



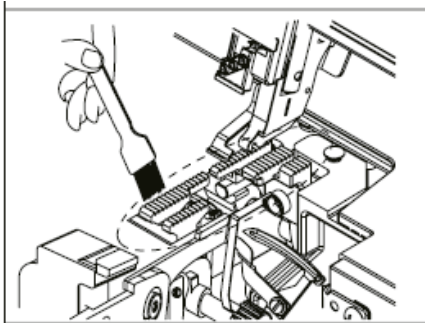

Afloje los tornillos que aseguran la placa de aguja y retire la placa de aguja.



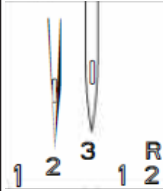

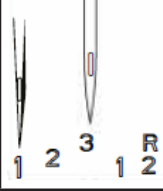

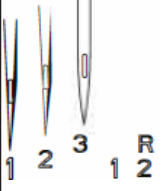

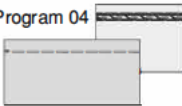
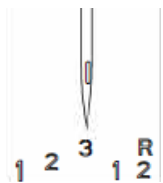
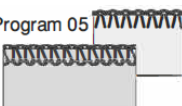
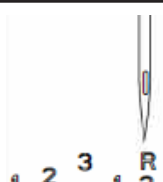
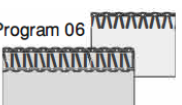
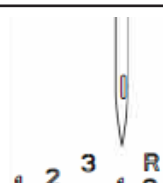
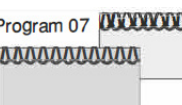
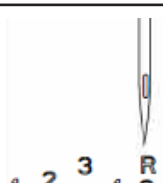
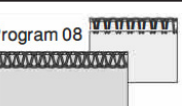
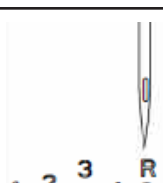

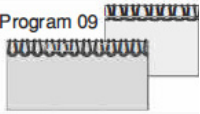
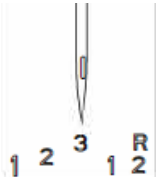
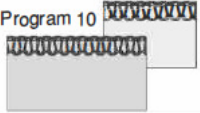
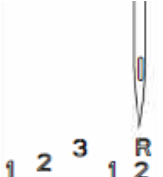
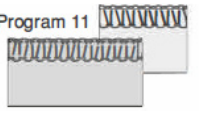

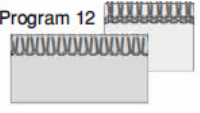
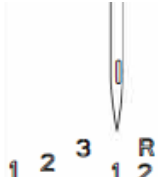
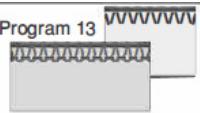
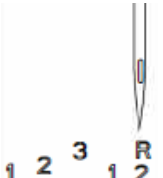
Limpe la lanzadera, el área de los dientes de arrastre con el cepillo accesorio.

COSIDO, COSTURA Y PUNTADAS DE KOVERLOCK, EJEMPLOS DE AJUSTES



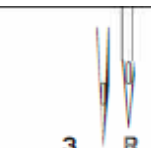

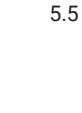

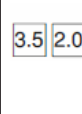
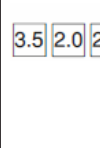

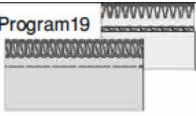
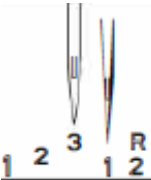
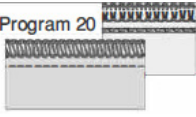
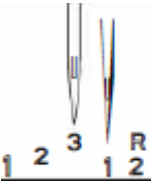

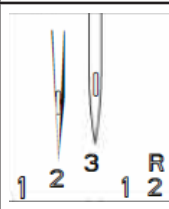

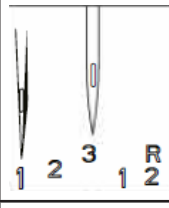
Programas	Posición de la aguja	Largo de la puntada	Ancho de la puntada	Tensión del hilo
Program 01  Programa 01	 1 2 3 1 R 2	2.5	5.0	5.0 5.0 _ _ 1.0
Program 02  Programa 02	 1 2 3 1 R 2	3.0	5.0	5.0 5.0 _ _ 1.0
Program 03  Programa 03	 1 2 3 1 R 2	3.0	5.0	5.0 4.5 5.0 _ 1.0





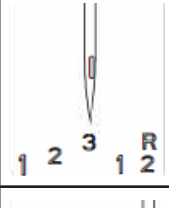

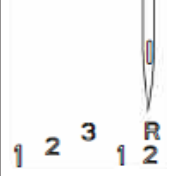

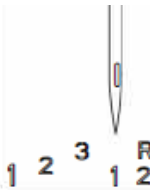

Programas	Posición de la aguja	Largo de la puntada	Ancho de la puntada	Tensión del hilo
Program 04  Programa 04	 1 2 3 1 2	3.0	5.0	3.0 _ _ _ 1.5
Program 05  Programa 05	 1 2 3 1 2	2.0	5.5	_ 1.5 _ 6.0 _
Program 06  Programa 06	 1 2 3 1 2	2.0	5.5	1.5 _ _ 6.0 _
Program 07  Programa 07	 1 2 3 1 2	2.0	5.5	_ 5.0 _ 2.5 _
Program 08  Programa 08	 1 2 3 1 2	1.0	5.5	_ 1.5 _ 5.0 _

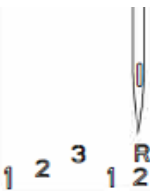

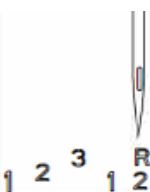

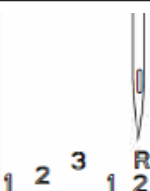

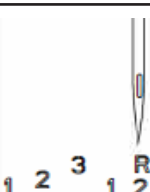

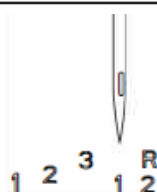

Programas	Posición de la aguja	Largo de la puntada	Ancho de la puntada	Tensión del hilo
Program 09  Programa 09	 1 2 3 1 2 R	1.0	5.5	- 3.0 - 3.0 -
Program 10  Programa 10	 1 2 3 1 2 R	2.0	5.5	- 3.5 3.5 2.5 -
Program 11  Programa 11	 1 2 3 1 2 R	2.0	5.5	3.0 - 1.0 1.0 -
Program 12  Programa 12	 1 2 3 1 2 R	2.0	5.5	4.5 - 0.5 7.5 -
Program 13  Programa 13	 1 2 3 1 2 R	1.0	5.5	- 0.5 3.0 6.0 -

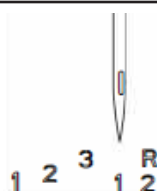

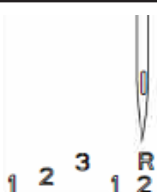

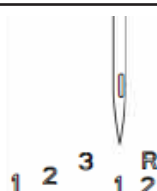

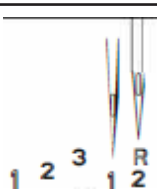



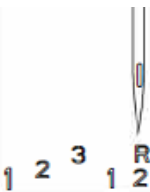

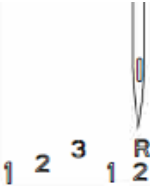
Programas	Posición de la aguja	Largo de la puntada	Ancho de la puntada	Tensión del hilo
Program 14  Programa 14	 1 2 3 1 2 R	2.0	5.5	0.5 _ 2.5 7.0 _
Program 15  Programa 15	 1 2 3 1 2 R	2.0	5.5	4.0 2.0 _ 1.0 _
Program 16  Programa 16	 1 2 3 1 2 R	1.0	5.5	_ 2.5 3.5 2.0 _
Program 17  Programa 17	 1 2 3 1 2 R	1.0	5.5	_ 3.0 2.0 6.0 _
Program 18  Programa 18	 1 2 3 1 2 R	2.5	5.5	3.5 2.0 2.0 1.5 _

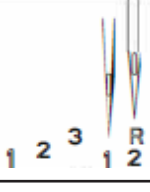
Programas	Posición de la aguja	Largo de la puntada	Ancho de la puntada	Tensión del hilo
 Program 19		2.5	8.0	3.0 0.5 _ 4.0 1.5
 Programa 20		3.0	8.5	3.0 2.5 1.0 1.0 1.5

Posición de la aguja	Largo de la puntada	Ancho de la puntada	Diferencial	Upper Knife	Cuchillo superior	convertidor de 2 hilos	Dedo ancho de puntada
	2.5	5.0	1.0	X			X
	3.0	5.0	1.0	X			X
	3.0	5.0	1.0	X			X
	3.0	5.0	1.0	X			X
	2.0	5.5	1.0	V			V

Posición de la aguja	Largo de la puntada	Ancho de la puntada	Diferencial	Upper Knife	Cuchillo superior	convertidor de 2 hilos	Dedo ancho de puntada
	2.0	5.5	1.0	V			V
	2.0	5.5	1.0	V			V
	1.0	5.5	1.0	V			X
	1.0	5.5	1.0	V			X
	2.0	5.5	1.0	V			V

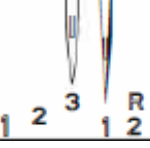
Posición de la aguja	Largo de la puntada	Ancho de la puntada	Diferencial	Upper Knife	Cuchillo superior	convertidor de 2 hilos	Dedo ancho de puntada
	3.0	5.5	1.0	V			V
	2.0	5.0	1.0	V			V
	2.0	5.5	1.0	V			V
	2.0	5.5	1.0	V			V
	2.0	5.5	1.0	V			V

Posición de la aguja	Largo de la puntada	Ancho de la puntada	Diferencial	Upper Knife	Cuchillo superior	convertidor de 2 hilos	Dedo ancho de puntada
	1.0	5.5	1.0	V			X
	1.0	5.5	1.0	V			X
	2.5	5.5	1.0	V			X
	2.5	8.0	1.0	V			X
	3.0	8.5	1.0	V			V

PRÉCAUTIONS DE SÉCURITÉ

Avant d'utiliser la machine, veuillez lire ce manuel.

N'utilisez pas la machine à une température ambiante supérieure à 45 °C ou inférieure à 5 °C, dans des pièces très humides ou ouvertes, sinon la machine risque de ne pas fonctionner correctement. Pour éviter la formation de condensation sur les appareils électroniques, il est déconseillé d'allumer la machine immédiatement à froid. Laisser la machine à température ambiante (et garder au chaud) avant de vous en servir. Il n'est pas recommandé d'utiliser la machine lorsque le réseau électrique est instable ou dans des endroits où il y a un fort champ électrique ou magnétique, sinon la machine va mal fonctionner. La machine doit être posée sur une surface plane et stable, en tenant compte du fait que la machine n'est ni trop proche du bord ni trop près d'un mur ou d'un obstacle.

Ne laissez pas tomber la machine, cela peut entraîner des dommages à la machine.

LORS DE L'UTILISATION DE LA MACHINE

Lors de l'utilisation de la machine, gardez vos mains éloignées des pièces mobiles de la machine, en particulier dans la zone des aiguilles. Pour éviter les décharges électriques ou les courts-circuits : tous les câbles doivent être en bon état et non endommagés (coupures, brûlures, etc.) et ne pas être en contact avec un environnement humide ou corrosif. Le câble d'alimentation doit bien tenir dans la prise secteur. Lorsque vous débranchez le cordon d'alimentation, ne tirez pas sur le cordon.

CONSERVEZ CES INSTRUCTIONS

Cette machine est destinée à un usage domestique uniquement.

Cette machine n'est pas destinée aux enfants, personnes souffrant de handicaps physiques, sensoriels ou mentaux ou manquant de connaissances et de compétences suffisantes, à moins qu'ils ne soient supervisés ou formés par des personnes responsables de leur sécurité. Les enfants doivent être surveillés pour s'assurer qu'ils ne jouent pas avec cet appareil.

Si les conditions d'utilisation et les règles de stockage de la machine à coudre sont respectées, la durée de vie de la machine à coudre est de 8 ans.

DÉCOUVREZ VOTRE MACHINE

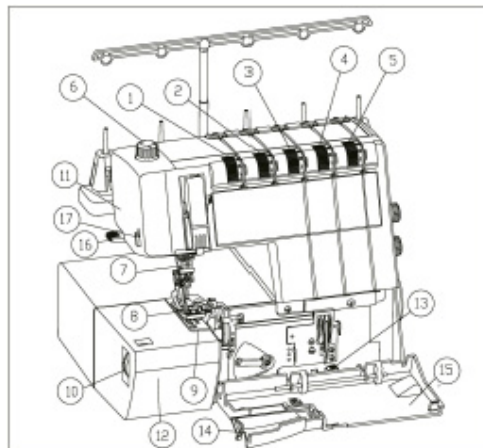

1. Cadran de tension du fil d'aiguille
2. Cadran de tension du fil d'aiguille
3. Cadran de tension du fil du boucleur supérieur
4. Cadran de tension du fil du boucleur supérieur
5. Cadran de tension du fil du boucleur de point de chaînette.

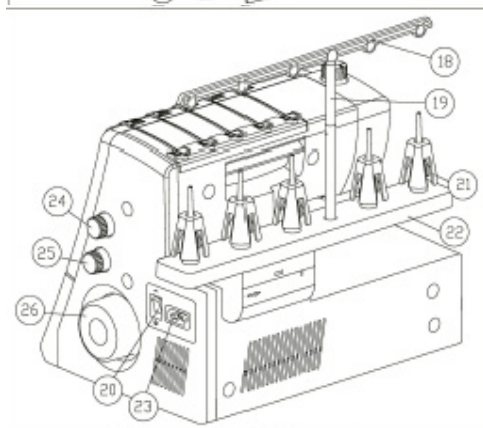

6. Régulateur de pression du pied-de-biche
7. Porte-aiguille
8. Pied standard
9. Plaque à aiguille
10. Ajusteur de surjet
11. Couvercle de la lampe
12. Couvercle gauche de la plateforme

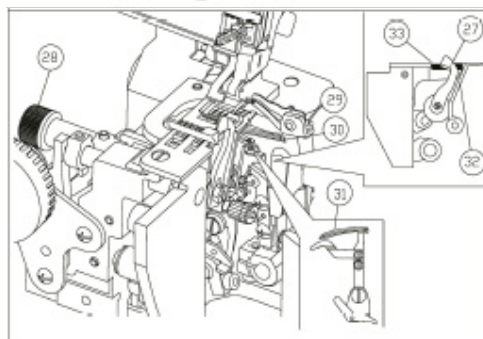

13. Levier de déverrouillage du boucleur
14. Insert de couvercle supérieur
15. Couvercle boucleur
16. Levier du pied de biche
17. Coupe-fil
18. Barre guide-fil



19. Barre télescopique
20. Interrupteur d'alimentation
21. Porte-bobine
22. Porte-bobine
23. Connecteur connexion de la pédale
24. Molette de longueur de point
25. Cadran d'alimentation différentielle
26. Volant
27. Couteau supérieur
28. Manche de coupe du couteau supérieur
29. Zone répétée droite (supérieure)
30. Boucleur gauche (inférieur)
31. Boucleur de couture et de couverture
32. Doigt de boucle
33. Couteau inférieur

* Faites glisser le capot avant (capot du boucleur) vers la droite et vers vous.

ACCESSOIRES INCLUS

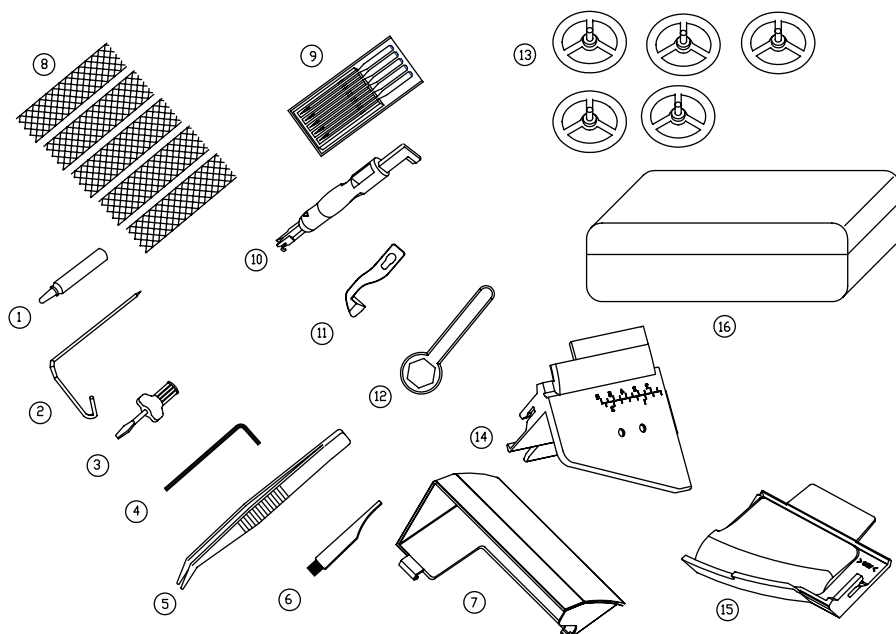

- | | |
|------------------------|--|
| 1. Huileur | 10. Enfile-aiguille manuel |
| 2. Règle | 11. Couteau supérieur |
| 3. Tournevis | 12. Clé |
| 4. Couteau hexagonal | 13. Disques de capture de canette |
| 5. Pince à épiler | 14. Cache boucleur insert horizontal pour tissage de tapis |
| 6. Brosse à ferraille | 15. Insert supérieur du couvercle du boucleur |
| 7. Conteneur à déchets | 16. Boîte d'accessoires. |
| 8. Filet de bobine | |
| 9. Jeu d'aiguilles | |

INITIATION À LA COUTURE

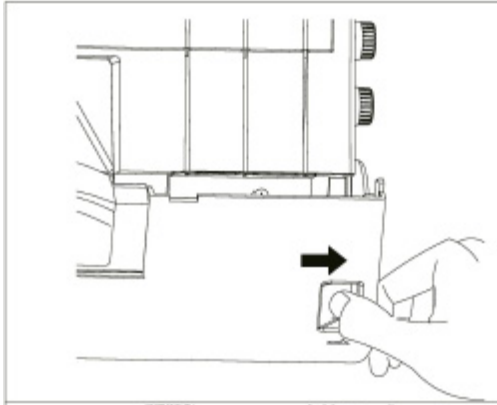

Couvercle du boucleur

Faites glisser le cache du boucleur vers la droite, puis tirez-le vers vous..

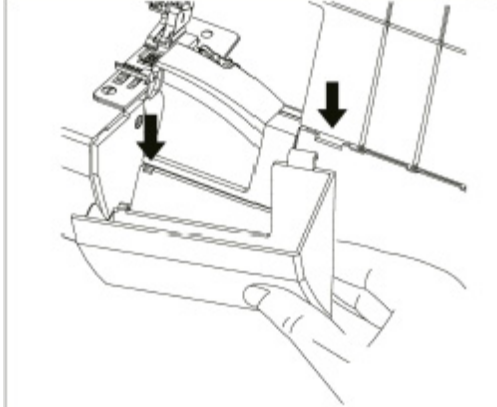

Conteneur à déchets

Appuyez sur le bas du conteneur jusqu'à ce que le loquet inférieur soit dans la fente.

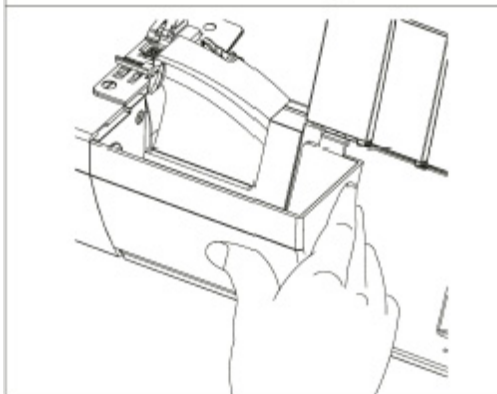

Pour retirer le conteneur, répétez cette étape.

GUIDE-FIL TÉLESCOPIQUE / PORTE-BOBINE / BUTÉE DE BOBINE

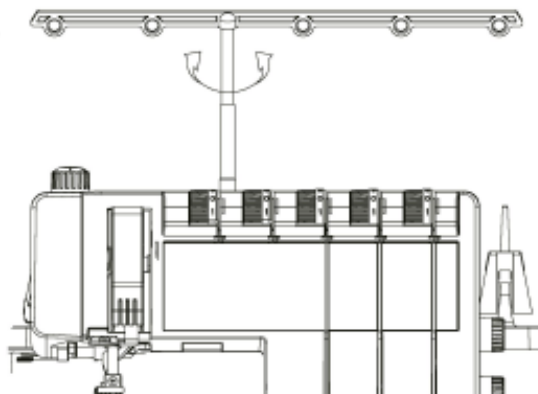

Guide-fil télescopique

Relevez le guide-fil télescopique à sa pleine hauteur. Pour un entraînement optimal du fil, tournez le guide-fil jusqu'à ce qu'il s'enclenche.

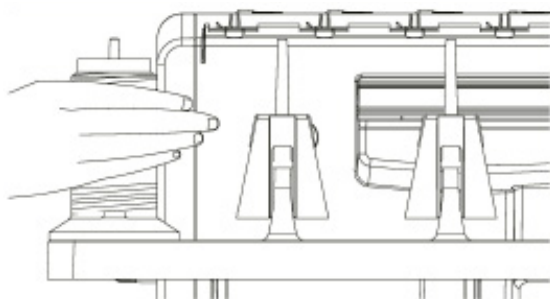

Porte-bobine

Lors de l'utilisation de grandes bobines (5 000 à 10 000 mm), utilisez les porte-bobines et les butées de bobine. Lorsque vous utilisez des fils synthétiques, les disques de support en polypropylène maintiennent les fils hors des canettes. Les supports de canette sont utilisés pour maintenir fermement les canettes sur les tiges.

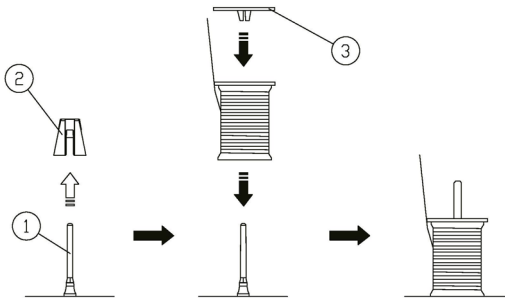
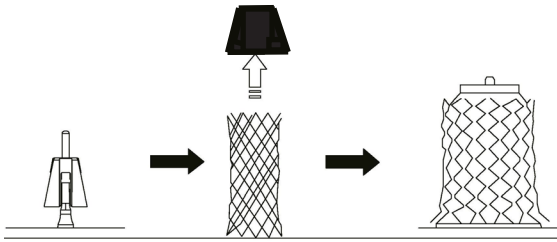

- 1) Goupille pour bobine et bobine
- 2) Porte-bobine
- 3) Butée de bobine

Butée de bobine

Si le fil se détache de la bobine lors de l'enfilage et/ou de la couture, faites glisser le filet sur la bobine. Lorsque vous utilisez de petites bobines, retirez les porte-bobines. Faites glisser les butées de bobine sur le dessus des bobines.

RELEVAGE DU PIED-DE-BICHE ET DES AIGUILLES

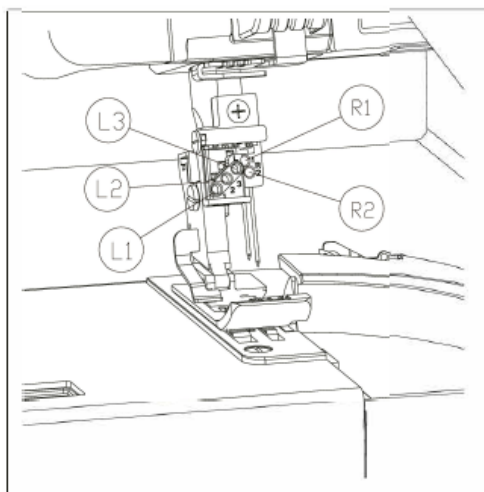

Vous pouvez coudre à partir de 5 positions d'aiguille. Vous pouvez coudre avec 3 aiguilles en même temps.

△ Remarque:

Lorsque les aiguilles sont insérées dans R1 et R2, l'aiguille gauche est placée plus haut que l'aiguille droite.

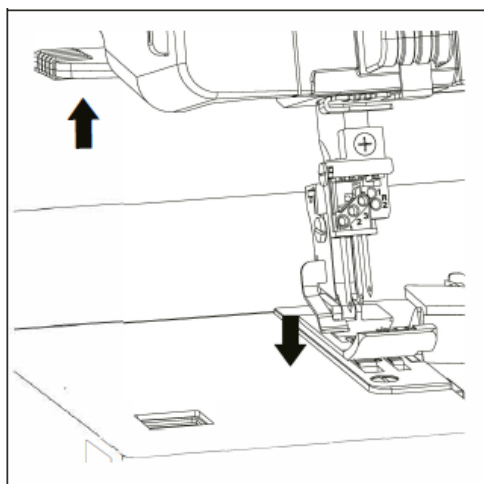

Lorsque les aiguilles L2 et L3 sont utilisées, l'aiguille gauche est réglée plus basse que la droite. Si L1 et L3 sont utilisés, l'aiguille gauche est également plus basse que l'aiguille droite.

Lorsque les aiguilles L1, L2 et L3 sont utilisées, l'aiguille gauche est à la position la plus basse. Le pied-de-biche peut être relevé/abaissé à l'aide du levier du levier de pied-de-biche.

△ Remarque:

Le pied-de-biche doit être abaissé pendant la couture.

REPLACEMENT DE L'AIGUILLE

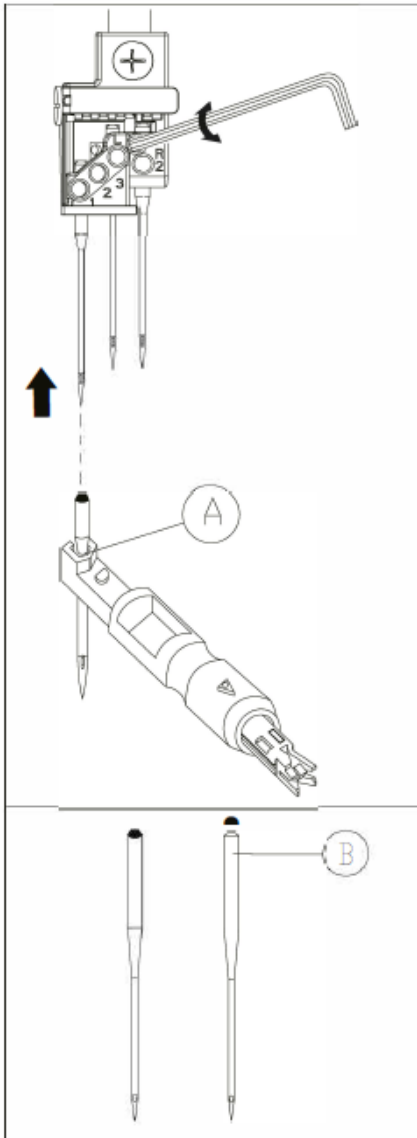

ÉTEIGNEZ L'ALIMENTATION DE LA MACHINE AVANT TOUTE INTERVENTION !

Pour retirer l'aiguille : Abaissez le pied-de-biche et relevez les aiguilles en position haute. Insérez l'aiguille à fond dans le porte-aiguille se trouvant dans la boîte d'accessoires.

Desserrez mais ne retirez pas la vis avec la clé hexagonale et tirez l'aiguille vers le bas.

Insérez l'aiguille : insérez l'aiguille dans le trou A du porte-aiguille spécial avec l'entaille B loin de vous. Insérez l'aiguille dans la base de la barre à aiguille aussi loin que possible et serrez avec une clé hexagonale. Retirez le porte-aiguille.

Système d'aiguille	Taille d'aiguille	Type de tissu
EL x 705	11-14 (75-90)	Tissus légers à moyens tels que soie, coton, stretch et tricots, jeans, etc.

BRANCHEMENT DE L'ALIMENTATION

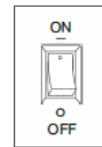
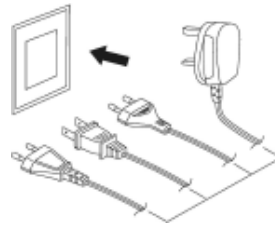
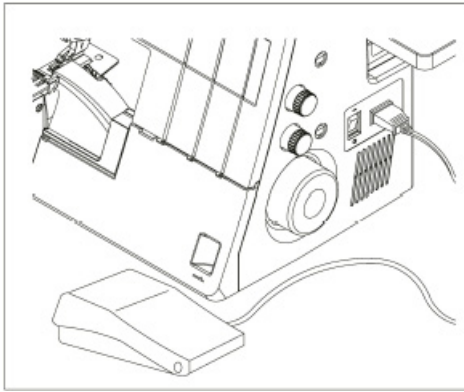

Attention : assurez-vous que la machine est débranchée et que l'interrupteur d'alimentation est en position « OFF » lorsque la machine n'est pas utilisée et avant de remplacer ou de déplacer des pièces.

Avant de brancher le cordon d'alimentation, assurez-vous que la tension indiquée sur l'appareil correspond à la tension secteur.

Placez l'appareil sur une surface stable.

1. Insérez la fiche d'alimentation dans l'appareil.
2. Insérez la fiche d'alimentation dans une prise de courant.
3. Mettez l'appareil sous tension.
4. La lampe d'éclairage de la zone de travail s'allume lorsque l'appareil est sous tension

Pour éteindre l'appareil, faites glisser l'interrupteur d'alimentation sur la position « OFF », puis retirez la fiche du connecteur.

COMMENCER À COUDRE



Allumez l'appareil comme décrit précédemment.

Pédale

La vitesse de couture est contrôlée par la pédale. Plus vous appuyez fort sur la pédale, plus la machine tourne vite. Levez le pied de biche et appuyez sur la pédale et entraînez-vous à travailler à différentes vitesses.

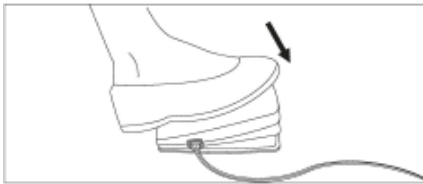

Pour votre sécurité :

- Regardez toujours la zone de couture pendant la couture. Ne touchez aucune pièce mobile de la machine, telle que le guide-fil, les boucleurs, le volant, l'aiguille, les couteaux.
- Coupez toujours l'alimentation si :
 - laissez la machine sans surveillance
 - changer ou ajouter des pièces
 - enfiler ou nettoyer la machine
- Ne rien poser sur la pédale, surtout lorsque la machine est en marche.

RÉGLAGE DE LA PRESSION DU PIED DE BICHE

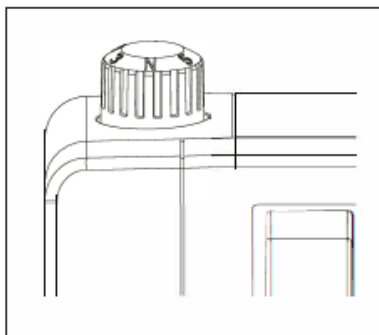

Pour une couture normale, il n'est pas nécessaire de modifier la pression du pied sur le tissu.

Lorsque vous cousez des tissus différents, tournez la vis de réglage en fonction du tissu.

Vous pouvez choisir parmi 6 positions différentes. Position standard «N»

△ ATTENTION:

Avant d'enfiler, éteignez la machine et débranchez-la.

ENFILAGE DES GUIDE-FILS

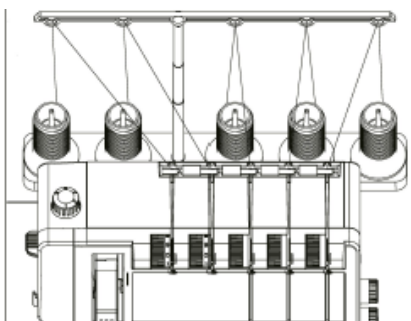

Relevez toujours le pied-de-biche avant d'enfiler la machine.

Tournez le volant vers vous et relevez les aiguilles en position haute.

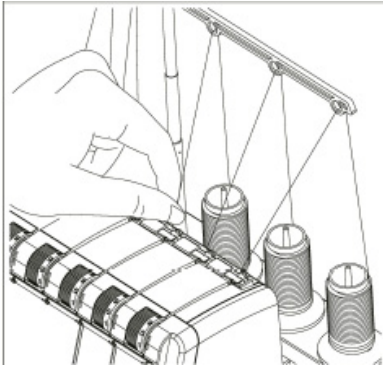

Enfilez la machine dans l'ordre suivant :

- 1) Enfilez le boucleur gauche
- 2) Fil de boucleur droit
- 3) Fil d'aiguille gauche
- 4) Fil d'aiguille droite

Relevez le levier du pied-de-biche.

④ ⑤ ① ② ③

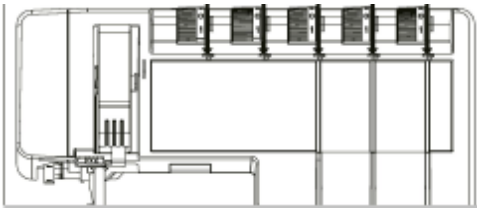

Séquence d'enfilage

ENFILAGE DU BOUCLEUR DROIT (SUPÉRIEUR)

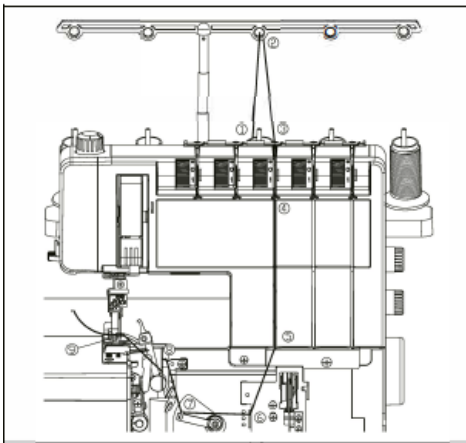

Tournez le volant vers vous jusqu'à ce que le boucleur remonte à la position la plus haute.

A - boucleur supérieur

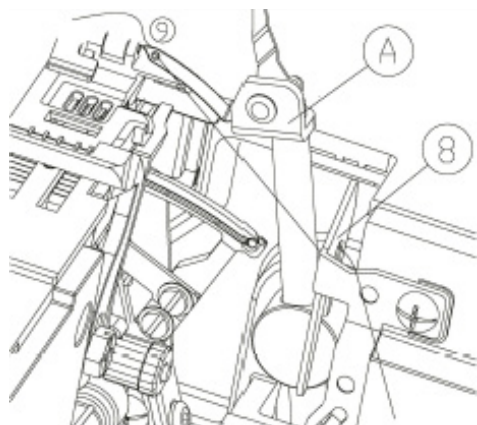

Enfilez le fil dans les guide-fil de l'étape 1 à l'étape 7.

Faites passer le fil par-dessus le guide-fil 8 par le haut et tirez-le vers le bas et vers la gauche jusqu'à ce qu'il pénètre dans la fourche du guide.

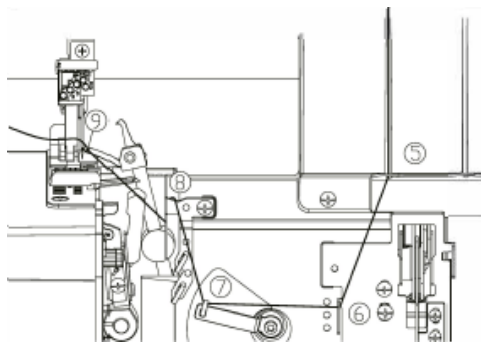

Tirez dans le chas du boucleur 9. Tirez 10 cm de fil et passez-le sous le pied de biche.

ENFILAGE DU BOUCLEUR GAUCHE (INFÉRIEUR)

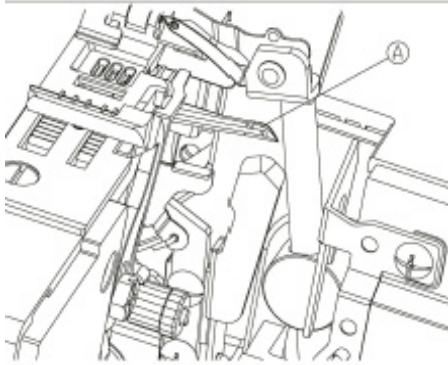

Tournez le volant vers vous jusqu'à ce que le boucleur se trouve à l'extrême droite.

A - boucleur inférieur

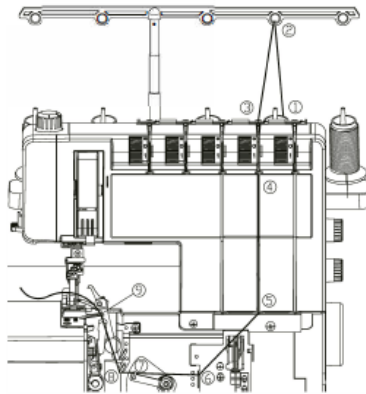

Enfilez le fil dans les guide-fil des étapes 1 à 9.

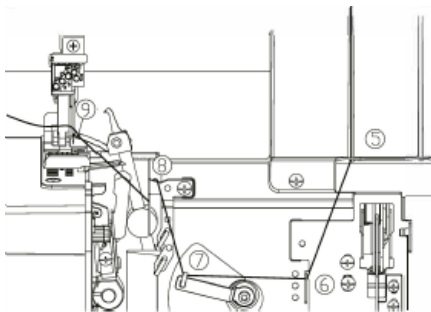

Abaissez le levier (a) et placez le fil sur le guide-fil (b). Enfilez le fil loin de vous dans l'œillet (c) à l'extrémité droite du boucleur.

Sortez 10 cm de fil et passez-le sous le pied.

ENFILAGE DU BOUCLEUR DE COUTURE POUR LA BOUCLE DE TAPIS (POINTS DE RECouvreMENT ET DE COUTURE)

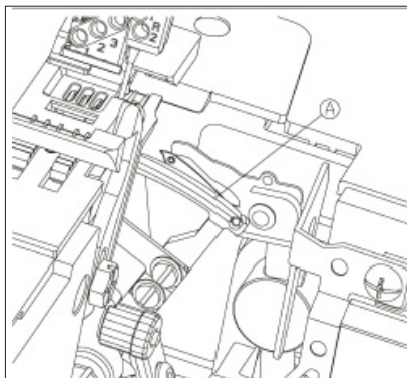

Tournez le volant jusqu'à ce que le boucleur de couture soit complètement à droite.

A - boucleur de couture

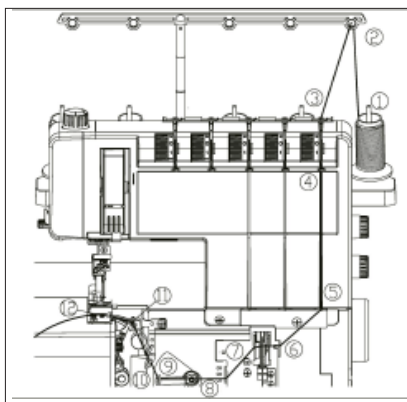

Faites passer le fil dans le guide-fil de l'étape 1 à 12.

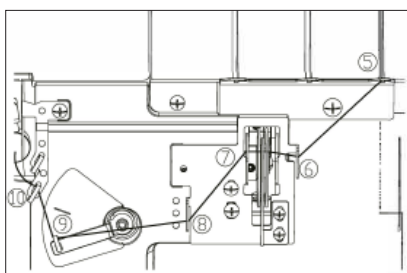

△ Remarque:

Lors de l'enfilage des étapes 6 et 7, le fil est simplement placé sur le dessus et n'est pas inséré à travers.

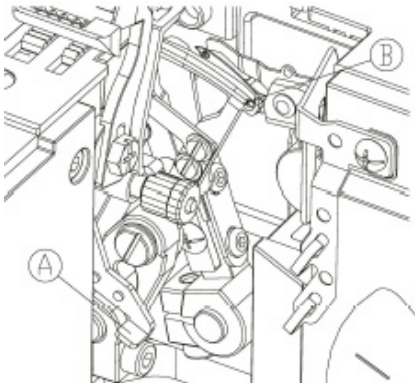

Relevez le levier (A) et enfitez la coupe (B).

△ Remarque:

Le levier reviendra à sa position d'origine dès que vous commencez à coudre.

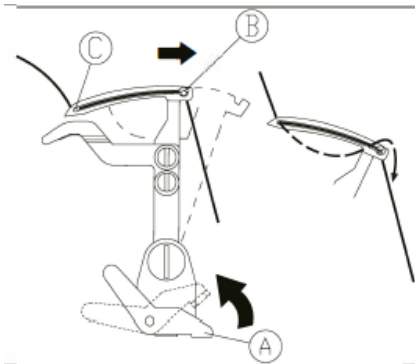

Passez le fil dans le chas du boucleur (C) loin de vous.

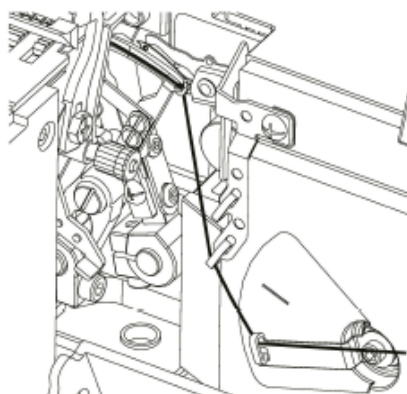

Tirez 10 cm de fil et passez-le sous le pied presseur.

ENFILAGE DE L'AIGUILLE

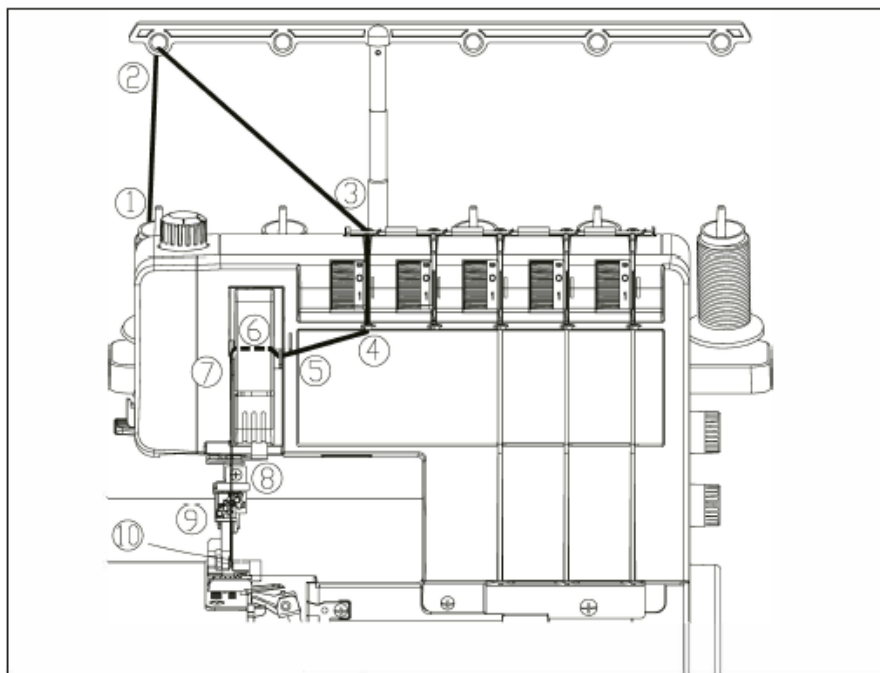

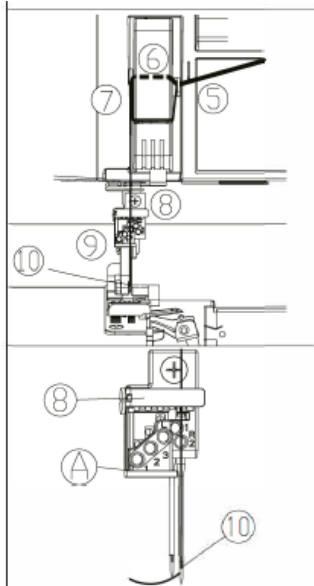

Enfilez les fils de l'étape 1 à l'étape 10.

Le fil doit passer par l'encoche inférieure du guide-fil 5

Tirez 10 cm de fil et tirez-le sous le pied de biche.

Si vous cousez avec des aiguilles L1, L2 ou L3, vous devez utiliser le guide-fil A.

Exception: Enfilez l'aiguille L3 lors de la couture avec le point overlock à 5 fils.

(Point 20) et lors de la couture avec le point overlock à 4 fils (Programme 19) et le point de couture à 2 fils (Point 04).

Enfilez dans l'ordre des étapes 1 à 10.

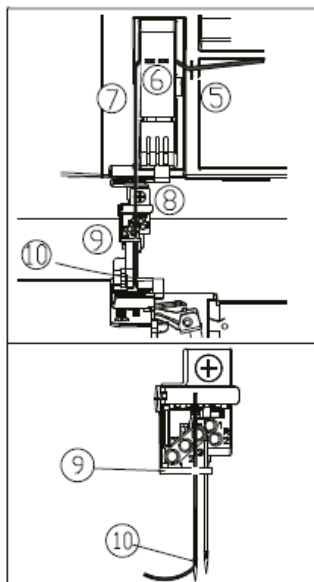

△ Remarque:

Lors de l'enfilage du boucleur de couture (Point 04), vous devez enfiler le tendeur de fil est vert. Le fil doit passer par l'encoche supérieure du guide-fil 6.

Tirez 10 cm de fil et tirez-le sous le pied de biche.

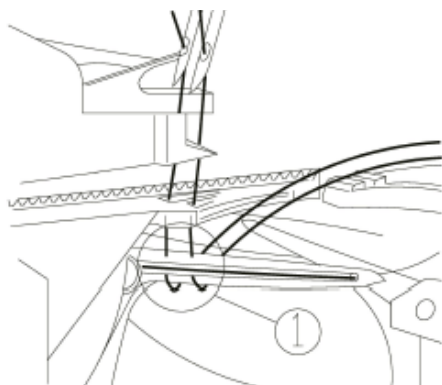
**Important lors de l'enfilage des aiguilles:**

Enfilez toujours les aiguilles en dernier pour éviter que les aiguilles ne se coincent dans les fils du boucleur, comme illustré à la fig. 1. Il devrait être au-dessus des fils du boucleur, comme sur la figure 2.

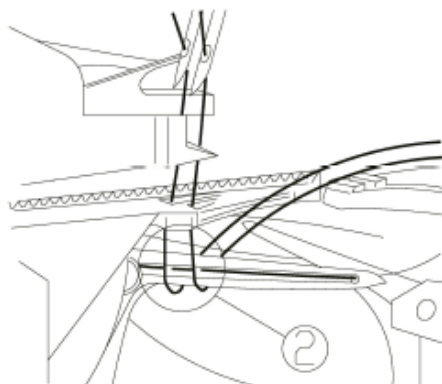

Sinon, les fils peuvent se casser. Si les fils des boucleurs sont déchirés, vous devez retirer les fils des aiguilles et enfilez les boucleurs, puis enfilez les aiguilles.

ENFILE-AIGUILLE MANUEL

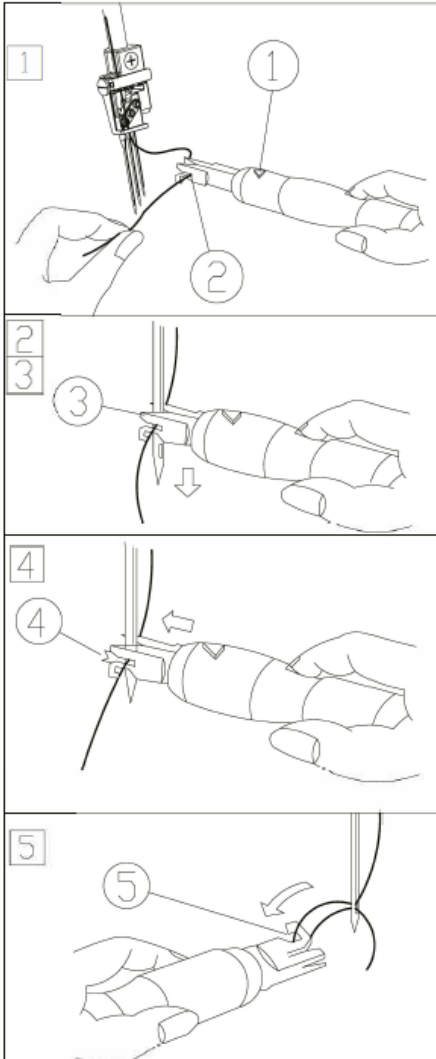

⚠ ÉTEIGNEZ L'ALIMENTATION DE LA MACHINE

Relevez les aiguilles à leur position la plus haute et abaissez le pied-de-biche.

Insérez le fil de droite à gauche dans l'encoche de l'enfileur A.

L'une des deux marques triangulaires doivent pointer vers le haut. Placez l'enfileur devant la rainure avant de l'aiguille, attrapez-le et abaissez-le jusqu'au chas de l'aiguille et poussez doucement l'enfileur à travers le chas. Une petite tige métallique traversera le chas de l'aiguille et enfilera automatiquement l'aiguille.

△ Remarque:

Si vous appuyez trop fort, la petite tige métallique peut se plier. Et l'enfileur échouera.

Utilisez maintenant le crochet 5 pour tirer la boutonnière à travers l'œillet.

SCHÉMA GÉNÉRAL DE THREADING POUR TOUS LES TYPES DE PROGRAMMES

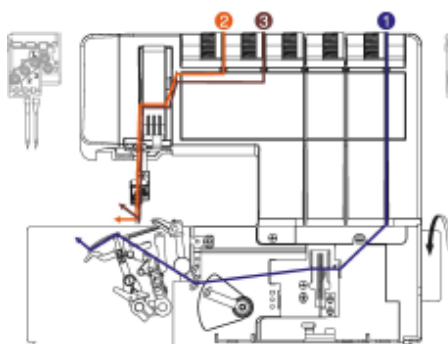

Point 01

Point de recouvrement étroit à 2 aiguilles (L2 / L3).

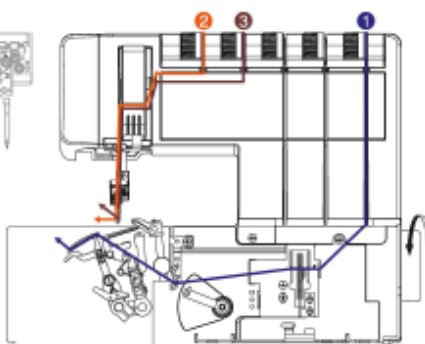

Point 02

Point de recouvrement à 2 aiguilles large (L1 / L3).

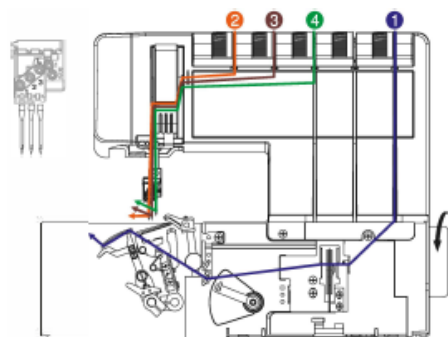

Point 03

Point de recouvrement à 2 aiguilles, large (L1 / L2 / L3).

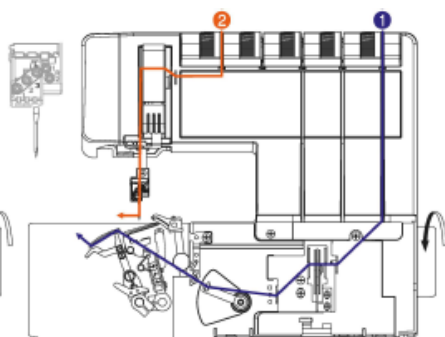

Point 04

Point de couture (L3) (point de chaînette à une aiguille).

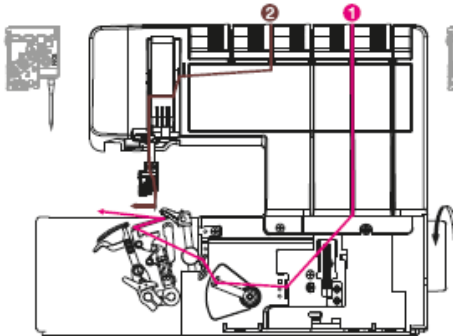

Point 05
Point étroit FlatLock à 2 fils (R2)

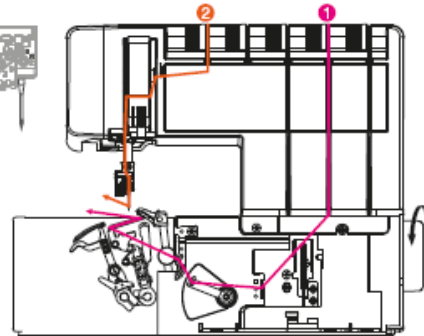

Point 06
Point FlatLock à 2 fils, large (R1)

Point 07
Surfilage 2 fils, étroit (R2)

Point 08
Point rouleau plat à 2 fils (R2)

Point 09
Point rouleau à 2 fils (R2)

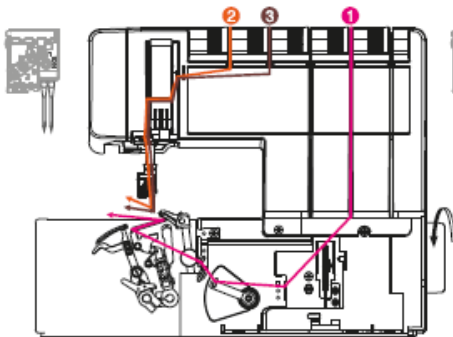

Point 10
Point de surjet à 2 aiguilles et 3 fils
(R1 / R2)

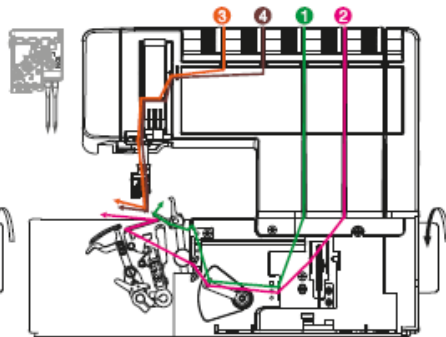

Point 11
Point overlock à 4 fils (R1 / R2)

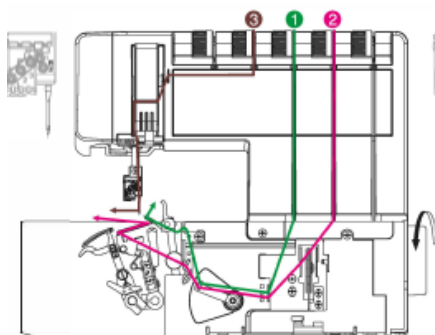

Point 12
Overlock 2 fils étroit (R2)

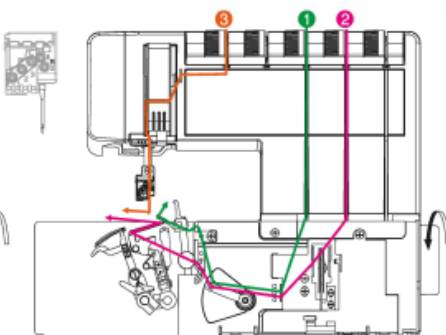

Point 13
Point overlock à 3 fils, large (R1)

Point 15
Point FlatLock à 3 fils, étroit (R2)

Point 14
Point overlock à 3 fils, étroit (R1)

Point 17
Point de rouleau plat à 3 fils (R2)

Point 16
Point FlatLock à 3 fils, large (R1)

Point 18
Ourlet roulé à 3 fils (R2)

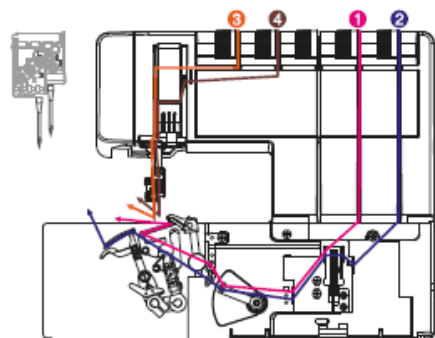

Point 19
Surtour à couture à 4 fils, point,
large (L3 / R1)

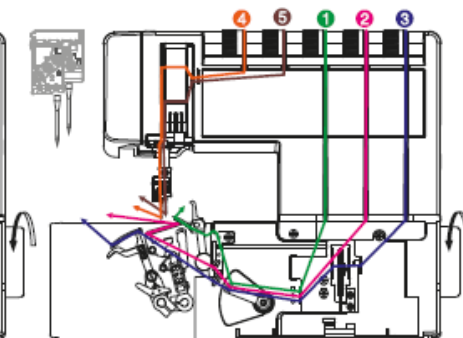

Point 20
Point overlock à 5 fils, large (L3 /
R1)

COUPE-FIL INTÉGRÉ

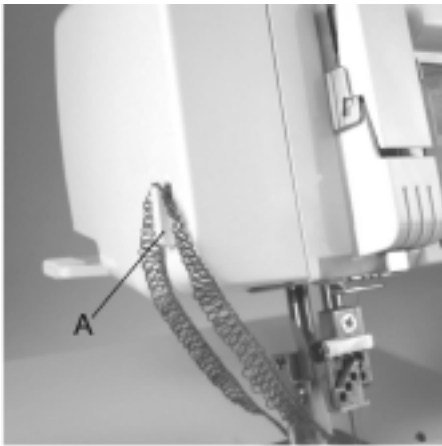

À la fin de la couture, laissez une chaîne de fil de 15-20 cm et tirez-la jusqu'au couteau coupe-fil. Cela coupera le fil

A - coupe-fil.



Placez le tissu directement devant les aiguilles. Si nécessaire, utilisez des ciseaux pour couper 3 cm le long du bord du tissu. Abaissez le pied et commencez à coudre. Le point est automatiquement cousu le long de la coupe.

△ **Remarque:**

Cette méthode convient à la couture de recouvrement.



Conteneur à déchets Fixez le conteneur à déchets au couvercle avant des boucleurs. Des bouts de tissu tomberont dedans.

DÉCONNECTER LE COUTEAU SUPÉRIEUR

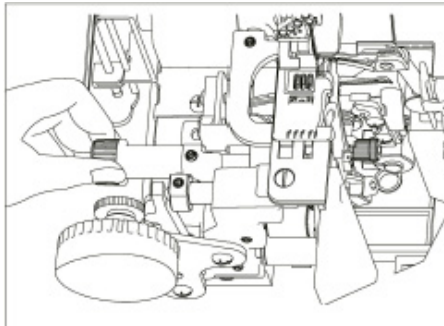

! ÉTEIGNEZ L'ALIMENTATION DE LA MACHINE!

Retirez la boîte de coupe et ouvrez le couvercle avant du boucleur et le couvercle gauche de la plate-forme. Relevez le couteau supérieur à sa position la plus élevée en tournant le volant .

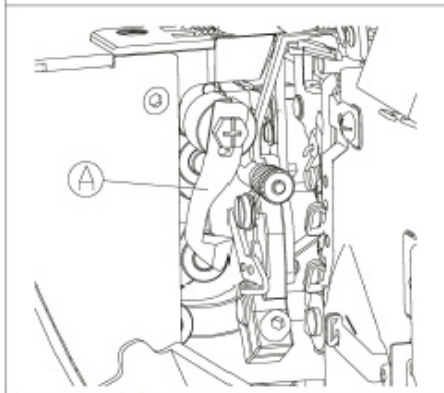

Maintenant, poussez le bouton de déverrouillage du couteau supérieur complètement vers la droite.

A - couteau supérieur

Tournez la poignée vers vous jusqu'à ce que le couteau supérieur soit abaissé. Le couteau est désactivé.

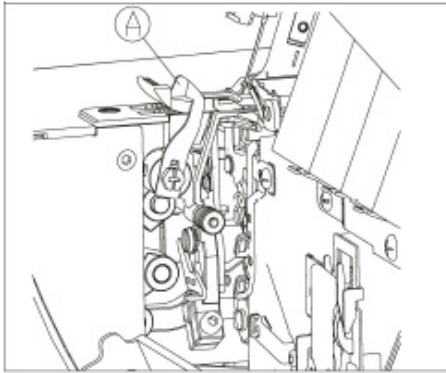

Allumez le couteau supérieur.

Poussez la poignée complètement vers la droite et tournez-la loin de vous jusqu'à ce qu'elles'enclenche. Le couteau remonte dans sa position de travail.

Fermez le couvercle du boucleur et le couvercle de la plate-forme gauche. Remettez le bac en lace

DÉSACTIVER BOUCLE DOIGT

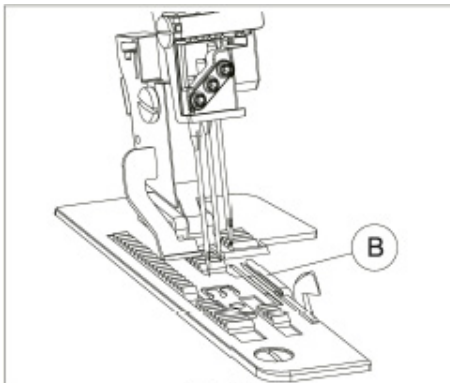

Pour les points overlock standard. Pour coudre avec tous les points overlock standard (programmes 02, 04), le doigt de boucle revient à sa position d'origine.

A - bouton de désactivation du doigt de boucle

B - doigt de boucle

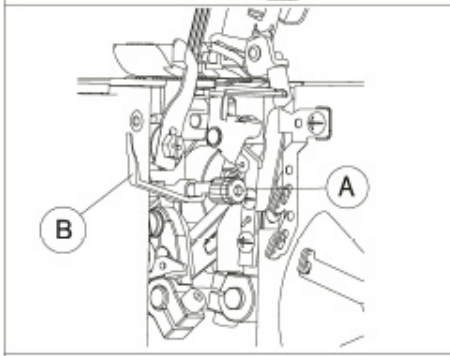

Pour les points au rouleau.

Retirez le bac de coupe et ouvrez le couvercle du boucleur avant. Tirez la poignée A vers la droite et abaissez la goupille de bouclage jusqu'à sa position inopérante en tournant la poignée vers vous.

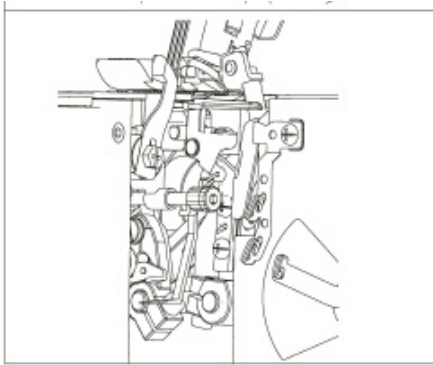

Avec ce réglage, vous pouvez coudre tous les points de rouleau. Egalement couverture et points décoratifs. (Programmes 02, 04).

CONVERTISSEUR BOUCLEUR DROIT (SUPÉRIEUR)

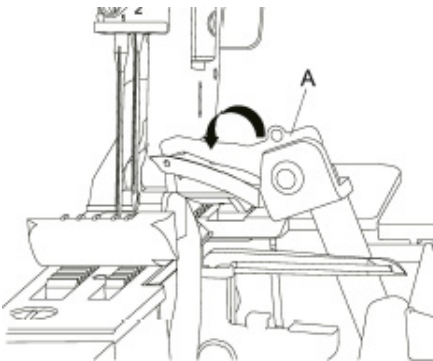

Activez le convertisseur à 2 fils: Tournez le volant jusqu'à ce que le boucleur droit (supérieur) monte à sa position la plus haute. Abaissez le convertisseur et insérez son crochet dans l'œillet du boucleur.

A - Convertisseur à 2 fils

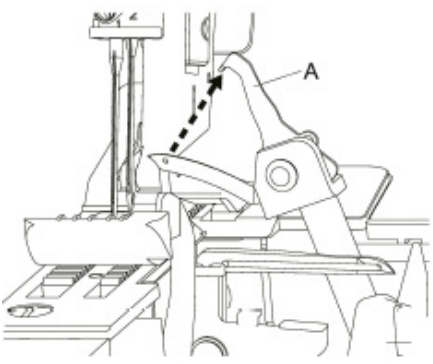

Déconnexion du convertisseur à 2 fils: Tournez le volant jusqu'à ce que le boucleur droit (supérieur), montez jusqu'à la position la plus haute. Retirez le crochet du convertisseur de l'œillet du boucleur et relevez le convertisseur à sa position d'origine (en haut à droite). sactivez le boucleur supérieur droit.

DÉSACTIVER DU BOUCLEUR DROIT (SUPÉRIEUR)

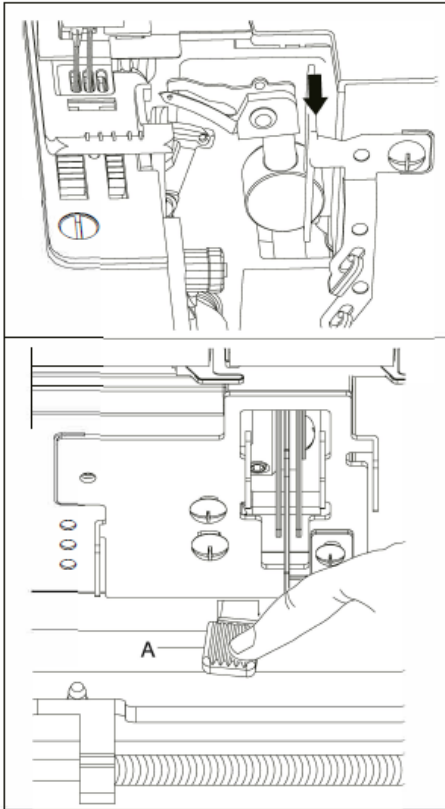

Pour coudre des surpiqûres, désactivez le boucleur droit (supérieur) à l'aide du levier de désactivation.

Retirez le conteneur à déchets et ouvrez le couvercle du boucleur avant. (1) Tournez le volant jusqu'à ce que le boucleur soit abaissé à sa position la plus basse.

A - Levier de désengagement du boucleur droit (supérieur).

Poussez le levier de déverrouillage du boucleur vers le bas et faites-le glisser vers la gauche. Tournez le volant pour vous assurer que le boucleur ne bouge pas.

Pour engager le boucleur supérieur droit, appuyez sur le levier de déverrouillage du boucleur et remettez-le dans sa position d'origine. Tournez le volant jusqu'à ce que le boucleur s'enclenche vers le haut.

Fermez le capot avant et remettez le bac à déchets en place.

RÉGLAGE DE LA LONGUEUR DE POINT ET DE L'AVANCE DIFFÉRENTIELLE

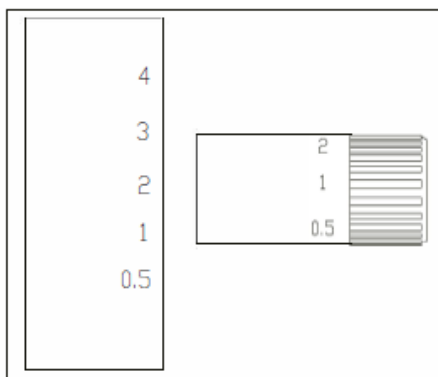

Tournez le sélecteur de longueur de point pour sélectionner la longueur de point souhaitée.

La longueur de point peut être réglée de 0,5 à 4.

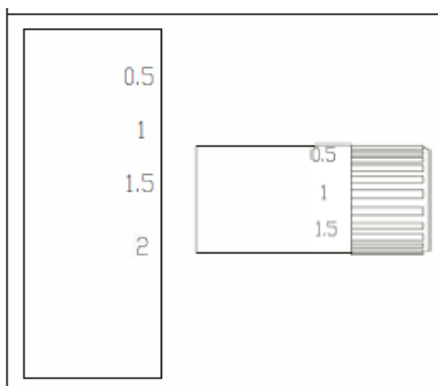

Tournez la molette d'alimentation différentielle pour sélectionner le rapport souhaité.

L'avance différentielle peut être réglée de 0,5 à 2.

REPLACEMENT DE L'INSERT SUPÉRIEUR DE LA HOUSSE DU BOUCLEUR

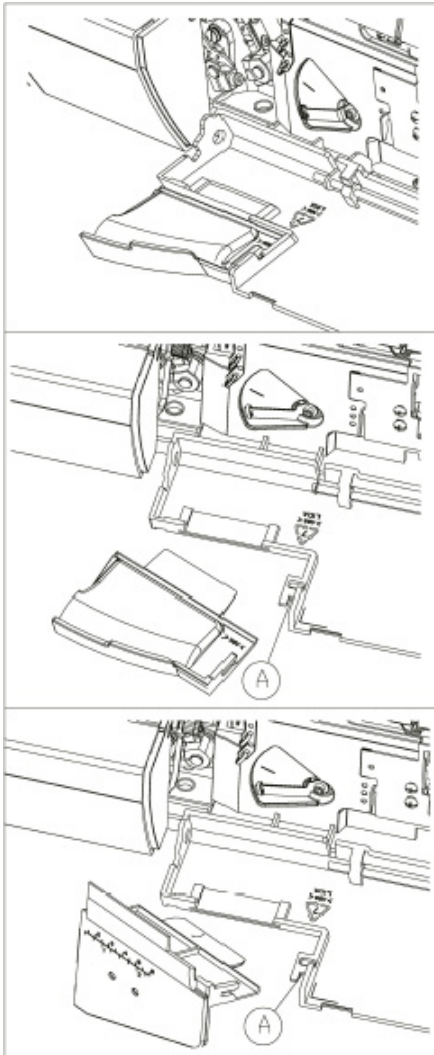

Retirez le bac à déchets et ouvrez le couvercle du boucleur. Tirez l'insert du couvercle du boucleur vers le haut et vers l'extérieur.

Pour insérer le point à cheval horizontal dans le capot avant, placez-le sous le loquet A. Et appuyez le long des guides du capot avant.

△ Remarque:

La plate-forme horizontale est marquée par des mesures. Les marques supérieures sont en centimètres et les marques inférieures sont en pouces.

RÉGLAGE DE LA LARGEUR DE COUPE DU TISSU

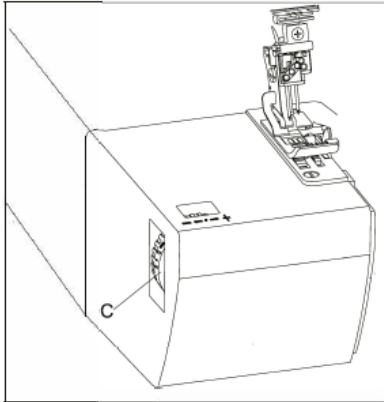

Tournez le bouton de réglage de la largeur de coupe pour sélectionner entre 3,5 et 6,0 mm.

Remarque: Le point de couture en chaînette est cousu de 0,5 à 9.

C: bouton de réglage de la largeur de coupe du tissu.

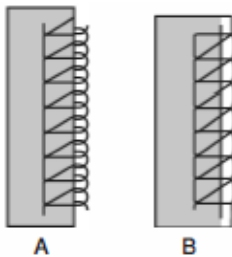

Si les boucles dépassent de la coupe du tissu, tournez le bouton de réglage pour déplacer le couteau vers le haut afin de déplacer le couteau vers la droite.

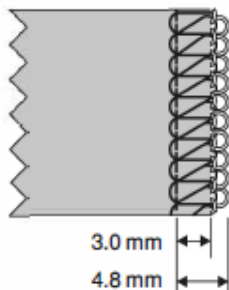
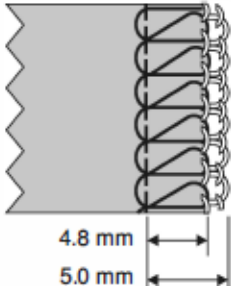

Fig. B, si les boutonnières resserrent la coupe du tissu, tournez le bouton de réglage vers le bas pour déplacer le couteau vers la gauche.



△ Remarque:

La largeur de coupe réglée de 4,8 mm à 5,0 mm n'est importante que pour le Aiguille R1... Cette valeur diminue de 2 mm lorsque l'aiguille R2 est utilisée.

FIXATION DE LA RÈGLE

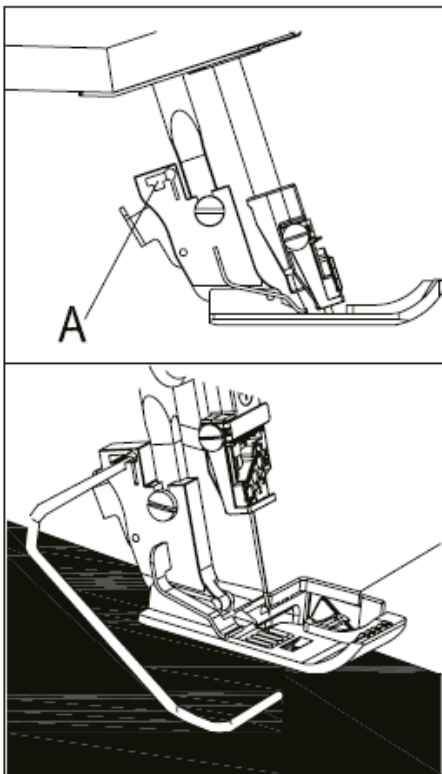

! Avant d'enfiler, éteignez la machine et débranchez-la.

Insérez la règle de couture et de quilting de gauche à droite dans la fente A du support de pied.

Vous pouvez ajuster la règle comme vous aimez en glissant vers la droite/gauche dans le support de pied.

Vous pouvez utiliser ces paramètres pour tous les points de rouleau.

REPLACEMENT DU COUTEAU SUPÉRIEUR

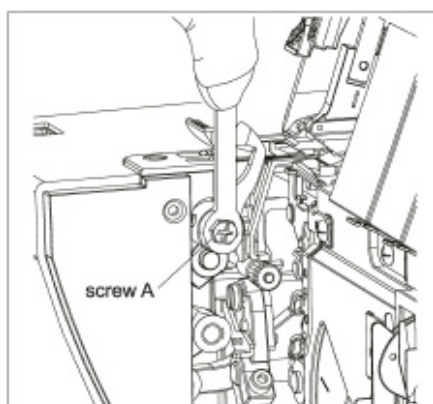

Retirez du couteau: Réglez le cadran de largeur de coupe sur 3,5 mm. Desserrez la vis A avec la clé fournie dans le kit d'accessoires. Et retirez le couteau supérieur.

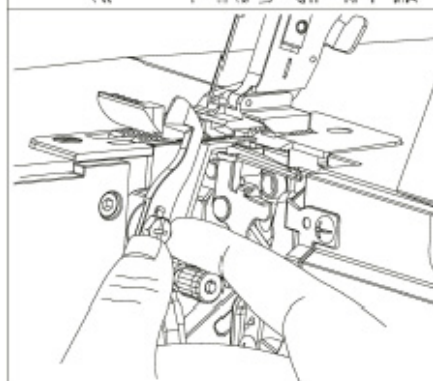

Installation du couteau: Installez le couteau supérieur et serrez légèrement la vis A. Tournez le volant jusqu'à ce que le couteau supérieur soit dans la position la plus basse.

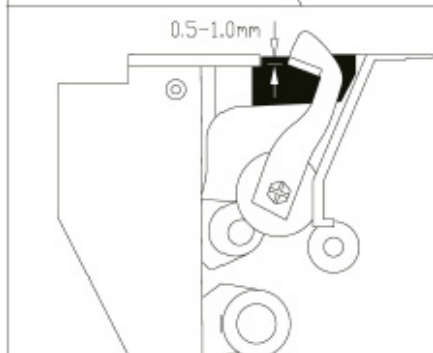

En position basse, l'extrémité avant du couteau supérieur doit se trouver à 1 mm sous le couteau inférieur lorsque vous avez correctement installé le couteau supérieur. Serrez complètement la vis A.

ENTRETIEN DE LA MACHINE

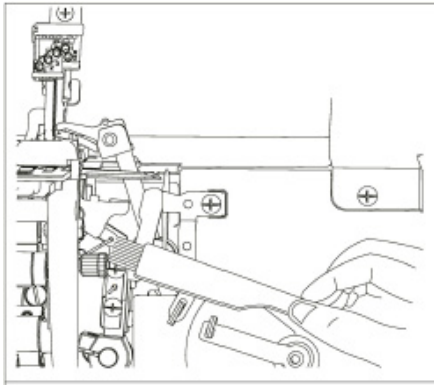

! Avant d'enfiler, éteignez la machine et débranchez-la.

Nettoyage de la machine.

Retirez le bac à déchets. Ouvrez le couvercle supérieur du oucleur et le couvercle de la plate-forme gauche. Déconnectez le couteau supérieur. Retirez le pied-de-biche et la plaque à aiguille.

Utilisez une brosse du kit d'accessoires pour enlever toute la poussière et la toison des couteaux supérieur et inférieur, des crémaillères et de la zone du boucleur.

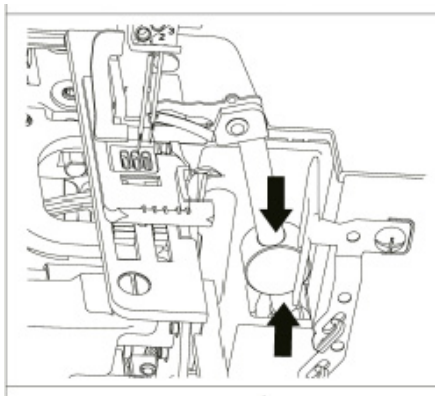

Lubrifiez la machine.

Déplacez le boucleur droit (supérieur) à la position la plus haute en tournant le volant. Après chaque nettoyage de la machine, lubrifiez la zone indiquée par les flèches sur l'illustration. 1-2 gouttes d'huile suffit.

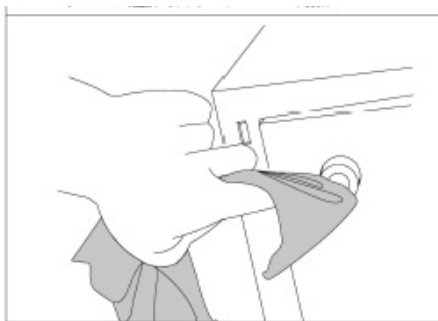
**Nettoyage des pieds en caoutchouc.**

Nettoyez les pieds en caoutchouc avec de l'alcool méthylique au fil du temps. Cela empêchera la machine de bouger pendant la couture.

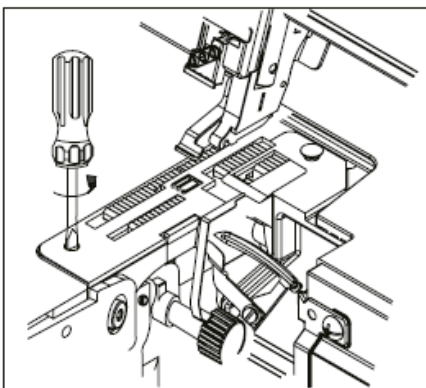
**Retrait de la plaque à aiguille.**

Retirez les aiguilles, retirez le pied-de-biche et le support de pied.

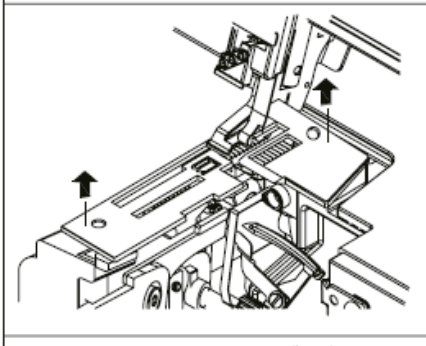



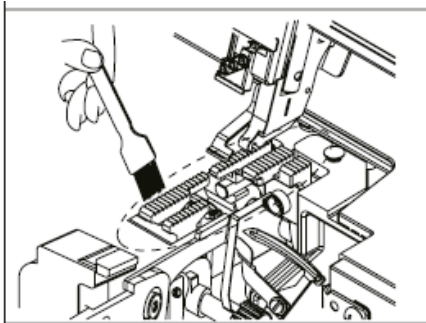





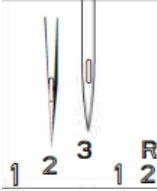
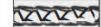

Desserrez les vis qui fixent la plaque à aiguille et retirez la plaque à aiguille.

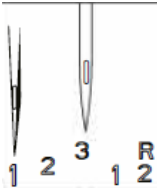

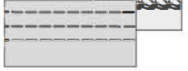
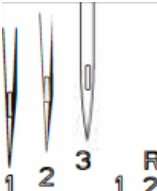

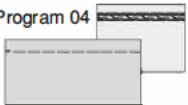
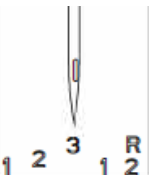
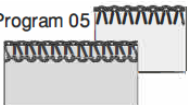
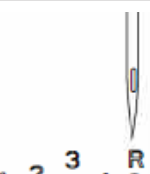
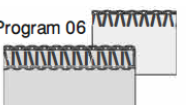
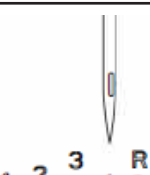

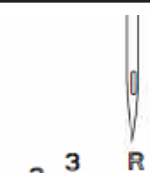

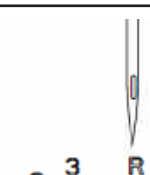
Nettoyez la zone des boucleurs, huilez avec une brosse du kit d'accessoires.

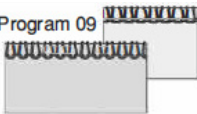
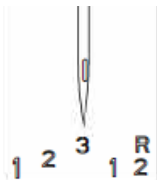

COUTURE, COUTURE ET POINTS DE TAPIS, EXEMPLES DE RÉGLAGES

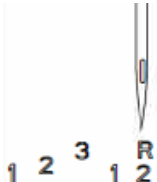
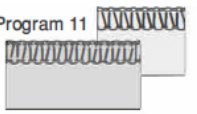
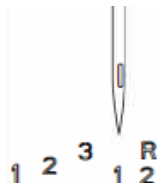
Programmes	Position de l'aiguille	Longueur de point	Largeur de point	Tension du fil
Program 01  	 1 2 3 1 R 2	2.5	5.0	5.0 5.0 _ _ 1.0
Program 02  	 1 2 3 1 R 2	3.0	5.0	5.0 5.0 _ _ 1.0
Program 03  	 1 2 3 1 R 2	3.0	5.0	5.0 4.5 5.0 _ 1.0

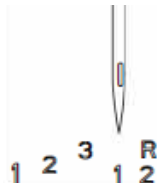
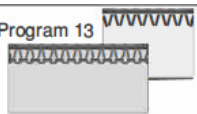
Programmes	Position de l'aiguille	Longueur de point	Largeur de point	Tension du fil
Program 04 	 1 2 3 1 R 2	3.0	5.0	3.0 _ _ _ 1.5
Program 05 	 1 2 3 1 R 2	2.0	5.5	_ 1.5 _ 6.0 _
Program 06 	 1 2 3 1 R 2	2.0	5.5	1.5 _ _ 6.0 _
Program 07 	 1 2 3 1 R 2	2.0	5.5	_ 5.0 _ 2.5 _
Program 08 	 1 2 3 1 R 2	1.0	5.5	_ 1.5 _ 5.0 _





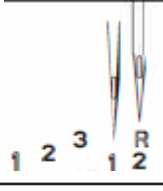
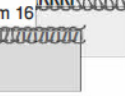
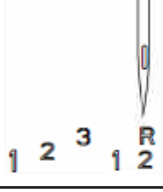
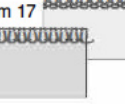
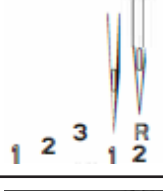
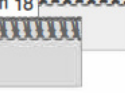
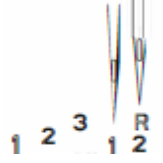



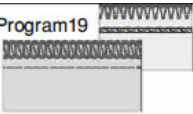
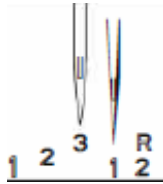
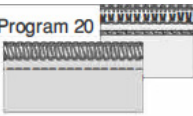
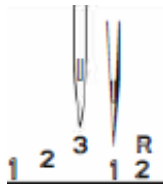

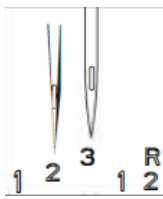

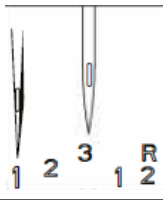





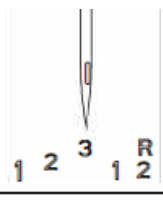

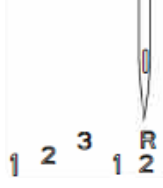

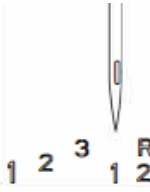

Programmes	Position de l'aiguille	Longueur de point	Largeur de point	Tension du fil
Program 09 		1.0	5.5	— <input type="text" value="3.0"/> — <input type="text" value="3.0"/> —
Program 10 		2.0	5.5	— <input type="text" value="3.5"/> <input type="text" value="3.5"/> <input type="text" value="2.5"/> —
Program 11 		2.0	5.5	<input type="text" value="3.0"/> — <input type="text" value="1.0"/> <input type="text" value="1.0"/> —
Program 12 		2.0	5.5	<input type="text" value="4.5"/> — <input type="text" value="0.5"/> <input type="text" value="7.5"/> —
Program 13 		1.0	5.5	— <input type="text" value="0.5"/> <input type="text" value="3.0"/> <input type="text" value="6.0"/> —

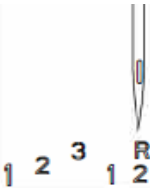

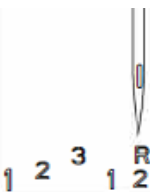

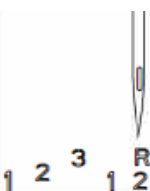

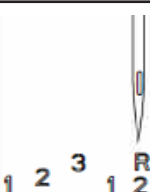



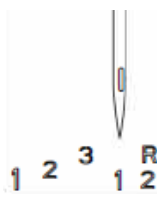

Programmes	Position de l'aiguille	Longueur de point	Largeur de point	Tension du fil
Program 14 		2.0	5.5	0.5 _ 2.5 7.0 _
Program 15 		2.0	5.5	4.0 2.0 _ 1.0 _
Program 16 		1.0	5.5	_ 2.5 3.5 2.0 _
Program 17 		1.0	5.5	_ 3.0 2.0 6.0 _
Program 18 		2.5	5.5	3.5 2.0 2.0 1.5 _



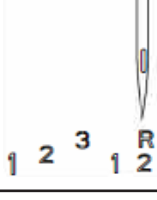

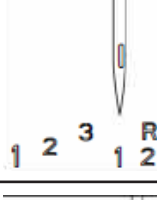

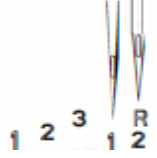



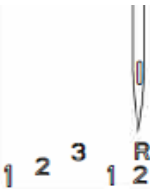

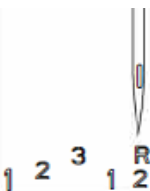
Programmes	Position de l'aiguille	Longueur de point	Largeur de point	Tension du fil
Program 19 		2.5	8.0	3.0 0.5 _ 4.0 1.5
Program 20 		3.0	8.5	3.0 2.5 1.0 1.0 1.5

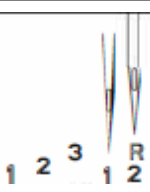
Position de l'aiguille	Longueur de point	Largeur de point	Avance différentielle	Couteau supérieur	Boucleur supérieur	Convertisseur 2 fils	Boucle doigt
	2.5	5.0	1.0	X			X
	3.0	5.0	1.0	X			X
	3.0	5.0	1.0	X			X
	3.0	5.0	1.0	X			X
	2.0	5.5	1.0	V			V

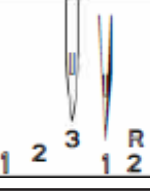
Position de l'aiguille	Longueur de point	Largeur de point	Avance différentielle	Couteau supérieur	Boucleur supérieur	Convertisseur 2 fils	Boucle doigt
	2.0	5.5	1.0	V			V
	2.0	5.5	1.0	V			V
	1.0	5.5	1.0	V			X
	1.0	5.5	1.0	V			X
	2.0	5.5	1.0	V			V

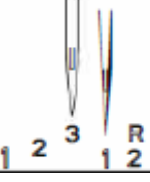
Position de l'aiguille	Longueur de point	Largeur de point	Avance différentielle	Couteau supérieur	Boucleur supérieur	Convertisseur 2 fils	Boucle doigt
	3.0	5.5	1.0	V			V
	2.0	5.0	1.0	V			V
	2.0	5.5	1.0	V			V
	2.0	5.5	1.0	V			V
	2.0	5.5	1.0	V			V

Position de l'aiguille	Longueur de point	Largeur de point	Avance différentielle	Couteau supérieur	Boucleur supérieur	Convertisseur 2 fils	Boucle doigt
	1.0	5.5	1.0	V			X
	1.0	5.5	1.0	V			X
	2.5	5.5	1.0	V			X
	2.5	8.0	1.0	V			X
	3.0	8.5	1.0	V			V

SICHERHEITSVORKEHRUNGEN

Lesen Sie bitte dieses Handbuch, bevor Sie das Gerät verwenden.

Verwenden Sie das Gerät nicht bei einer Umgebungstemperatur von mehr als 45 °C oder niedriger als 5 °C, in Räumen mit hoher Luftfeuchtigkeit oder unter freiem Himmel, sonst funktioniert die Maschine möglicherweise nicht richtig. Um die Bildung von Kondenswasser auf elektronischen Geräten zu vermeiden, wird nicht empfohlen, das Gerät sofort aus der Kälte einzuschalten. Bei Zimmertemperatur warm werden lassen (und warm halten). Es wird nicht empfohlen, die Maschine bei instabilem Stromnetz oder in einem starken elektrischen oder magnetischen Feld zu verwenden, da sonst die Maschine gestört wird. Die Maschine muss auf einer ebenen, stabilen Fläche abgestellt werden, wobei zu berücksichtigen ist, dass die Maschine einen ausreichenden Abstand zu stehenden Gegenständen hat und diese nicht berührt.

Lassen Sie die Maschine nicht fallen, dies kann zu Personen- oder Sachschäden führen an der Maschine.

BEIM BETRIEB DER MASCHINE

Halten Sie beim Betrieb der Maschine Ihre Hände von beweglichen Teilen der Maschine fern, insbesondere im Bereich der Nadeln. Um Stromschläge oder Kurzschlüsse zu vermeiden: Alle Kabel müssen in gutem Zustand und unbeschädigt sein (Schnitte, Verbrennungen usw.) und dürfen nicht in Kontakt mit einer feuchten oder korrosiven Umgebung kommen. Das Netzkabel muss guten Kontakt zum Stromnetz haben. Ziehen Sie beim Abziehen des Netzkabels nicht am Kabel.

BEWAHREN SIE DIESE ANWEISUNGEN AUF

Dieses Gerät ist nur für den Hausgebrauch bestimmt.

Dieses Gerät ist nicht für den Gebrauch von Menschen (einschließlich Kinder) mit eingeschränkten physischen, sensorischen oder geistigen Fähigkeiten oder ohne ausreichende Kenntnisse und Fähigkeiten geeignet, es sei denn, sie werden von Personen beaufsichtigt oder geschult, die für ihre Sicherheit verantwortlich sind. Kinder sollten beaufsichtigt werden, um sicherzustellen, dass sie nicht mit diesem Gerät spielen.

Bei Beachtung der Betriebsbedingungen und Lagervorschriften der Nähmaschine beträgt die Lebensdauer der Nähmaschine 8 Jahre.

LERNEN SIE IHRE

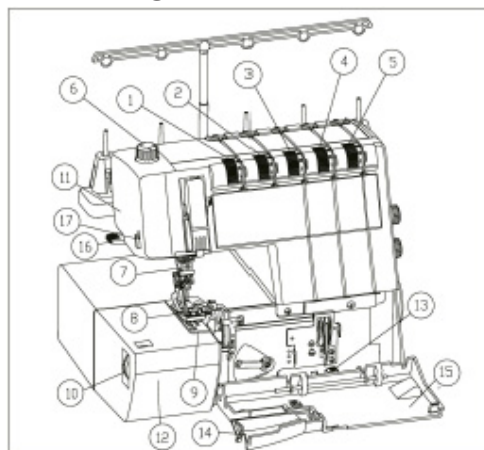

1. Nadelfadenspannungs-Einstellrad
2. Nadelfadenspannungs-Einstellrad
3. Fadenspannungsregler für den Obergreifer
4. Fadenspannungsregler für den Obergreifer
5. Fadenspannungsregler für den Kettenstichgreifer

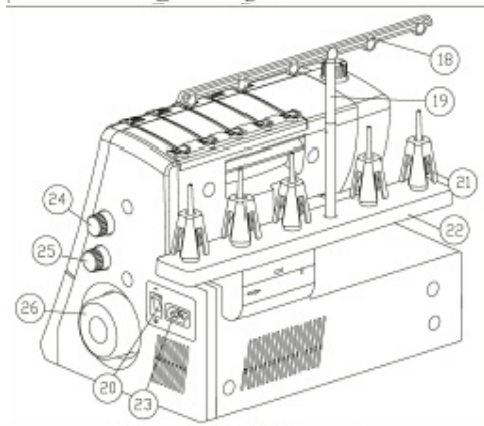

6. Nähfußdruckregler
7. Nadelhalter
8. Standardfuß
9. Stichplatte
10. Bewölkungseinsteller
11. Lampenabdeckung
12. Linke Plattformabdeckung
13. Greiferfreigabehebel
14. Einsatz für obere Abdeckung

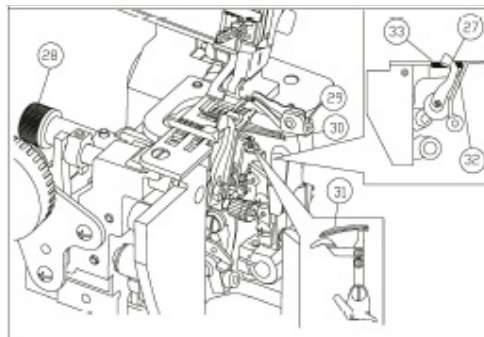

15. Greiferabdeckung
16. Fußlüftungshebel
17. Fadenabschneider
18. Fadenführungsstange

19. Teleskopstange
20. Stromschalter
21. Spulenhalter
22. Spulenhalter
23. Pedalanschluss
24. Stichtlängen-Einstellrad
25. Differenzialtransport-Einstellrad
26. Schwungrad
27. Obermesser
28. Abschneidegriff des Obermessers
29. Rechter (oberer) Greifer
30. Linker (unterer) Greifer
31. Greifer binden und abdecken
32. Schlingenfinger
33. Untermesser

* Schieben Sie die vordere Abdeckung (Greiferabdeckung)
nach rechts und zu sich hin.

INKLUSIVE ZUBEHÖR

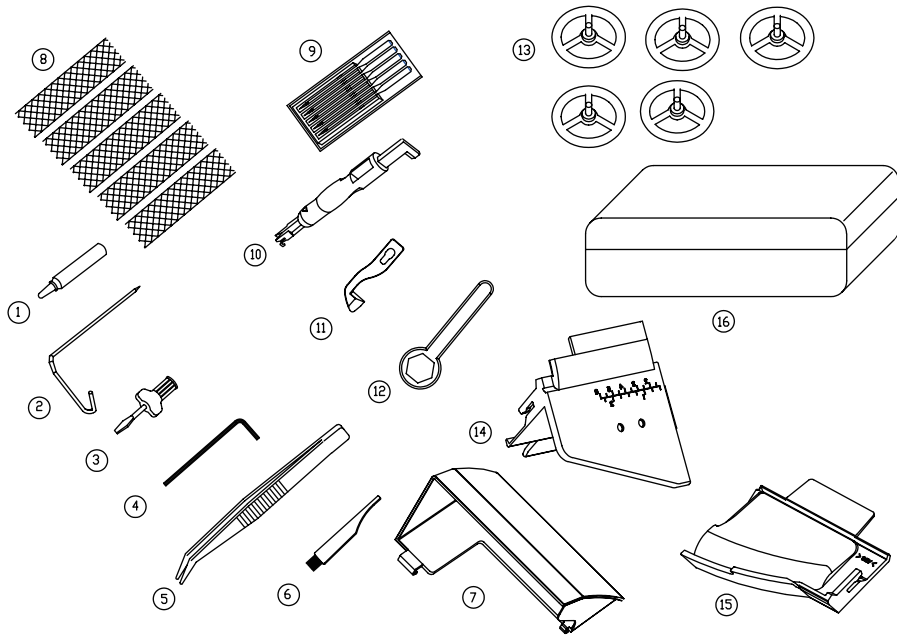

- | | |
|--------------------|--|
| 1. Öl | 10. Manueller Nadeleinfädler |
| 2. Lineal | 11. Obermesser |
| 3. Schraubendreher | 12. Taste |
| 4. Sechskantmesser | 13. Spulenfangscheiben |
| 5. Pinzette | 14. Horizontale Einlage Greiferabdeckung zum Weben von Teppichen |
| 6. Schrottpinsel | 15. Oberer Einsatz der Greiferabdeckung |
| 7. Abfallbehälter | 16. Zubehörbox. |
| 8. Spulennetz | |
| 9. Nadelsatz | |

VORBEREITUNG FÜR DAS NÄHEN

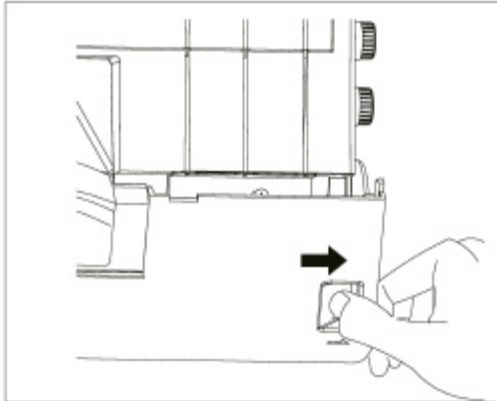

Greiferabdeckung

Schieben Sie die Greiferabdeckung nach rechts und ziehen Sie sie dann zu sich hin.

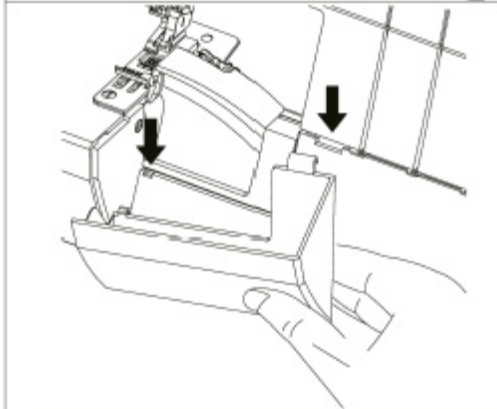

Abfallbehälter

Drücken Sie auf den Boden des Behälters, bis sich die untere Verriegelung im Schlitz befindet.

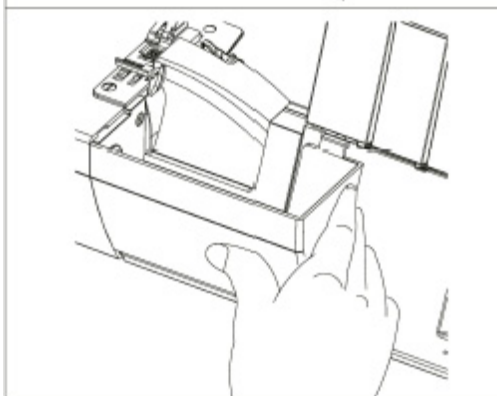

Wiederholen Sie diesen Schritt, um den Behälter zu entfernen.

TELESKOPFADENFÜHRUNG / SPULENHALTER / GARNROLLENHALTER

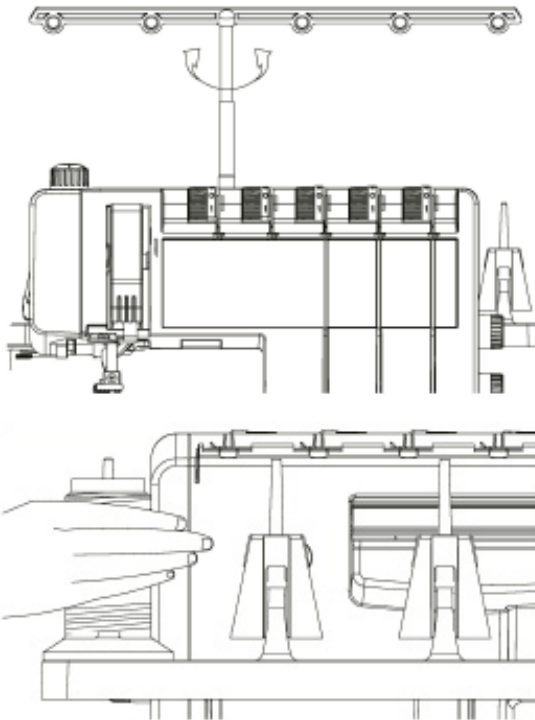

Teleskopfadenführung

Heben Sie die Teleskopfadenführung auf ihre volle Höhe an. Für eine optimale Fadenzufuhr drehen Sie die Fadenführung heraus, bis sie einrastet.

Spulenhalter

Verwenden Sie bei großen Spulen (5.000-10.000 mm) die Spulenhalter und Spulenstopper. Bei der Verwendung von synthetischen Fäden halten die Polypropylen-Trägerscheiben die Fäden von den Spulen ab.

Die Spulenhalter dienen dazu, die Spulen fest auf den Stäben zu halten.

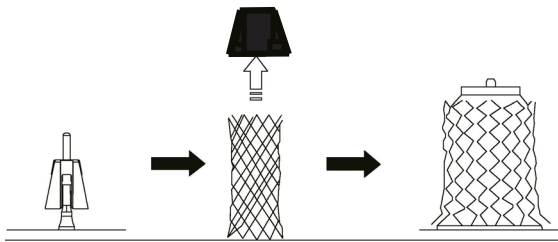

1) Stift für Spule und Spule

2) Spulenhalter

3) Spulenstopper

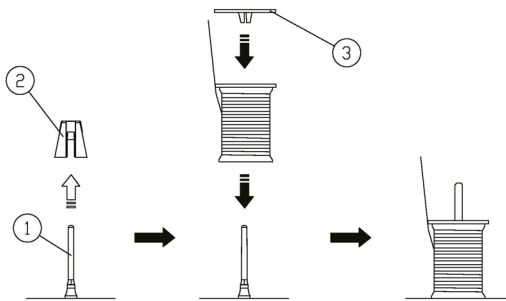

Garnrollenhalter

Wenn sich der Faden beim Einfädeln und/oder Nähen von der Garnrolle löst, schieben Sie das Netz über die Garnrolle.

Wenn Sie kleine Garnrollen verwenden, entfernen Sie die Garnrollenhalter. Schieben Sie die Spulenstopper über die Spulen.

NÄHFUSS UND NADELLIFT

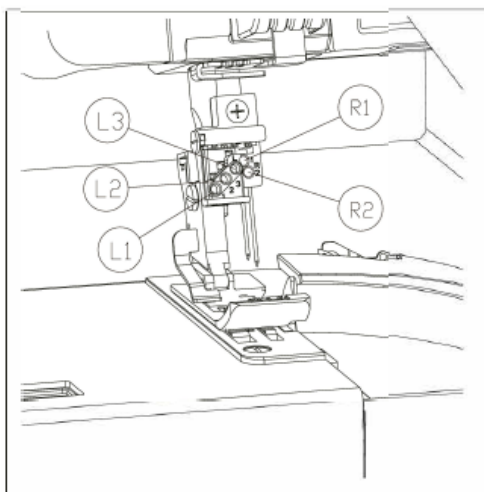

Nähfuß und Nadeln anheben Sie können in fünf verschiedenen Nadelpositionen nähen. Sie können 3 Nadeln gleichzeitig nähen.

△ Hinweis:

Wenn Nadeln in R1 und R2 eingesetzt werden, wird die linke Nadel höher eingestellt als die rechte.

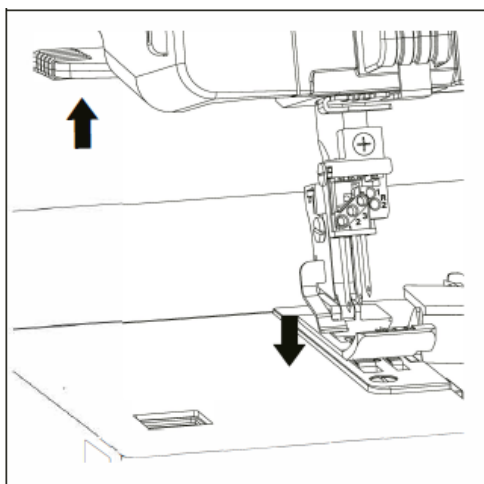

Wenn die Nadeln L2 und L3 verwendet werden, linke Nadel ist tiefer eingestellt als die rechte. Bei Verwendung von L1 und L3 ist die linke Nadel auch tiefer als die rechte Nadel. Wenn die Nadeln L1, L2 und L3 verwendet werden, befindet sich die linke Nadel in der tiefsten Position. Der Nähfuß kann mit dem Nähfußheberhebel angehoben / abgesenkt werden.

△ Hinweis:

Der Nähfuß muss beim Nähen abgesenkt sein.

AUSTAUSCH VON NADELN

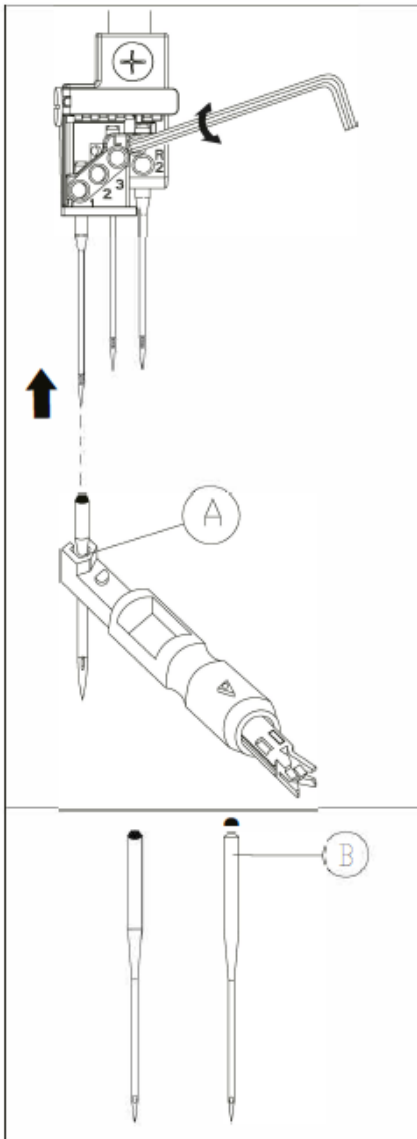

! SCHALTEN SIE DIE MASCHINE AUS!

Entfernen der Nadel: Senken Sie den Nähfuß und heben Sie die Nadeln in die obere Position. Stecken Sie die Nadel so weit wie es wird in den Nadelhalter in der Zubehörbox gesteckt. Lösen Sie die Schraube mit dem Inbusschlüssel, aber entfernen Sie sie nicht und ziehen Sie die Nadel nach unten.

Einführen der Nadel: Führen Sie die Nadel mit dem Schnitt B von Ihnen weg in das Loch A des speziellen Nadelhalters ein. Führen Sie die Nadel bis zum Anschlag in die Basis der Nadelstange ein und ziehen Sie sie mit einem Inbusschlüssel fest. Entfernen Sie den speziellen Nadelhalter.

Nadelsystem	Nadelstärke	Stoffart
EL x 705	11-14 (75-90)	Leichte bis mittlere Stoffe wie Seide, Baumwolle, Stretch und Strick, Jeans usw.

ANSCHLIESSEN DER STROMVERSORGUNG

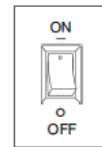
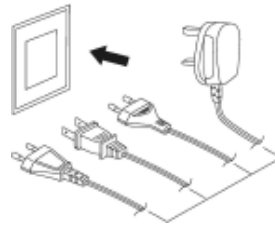
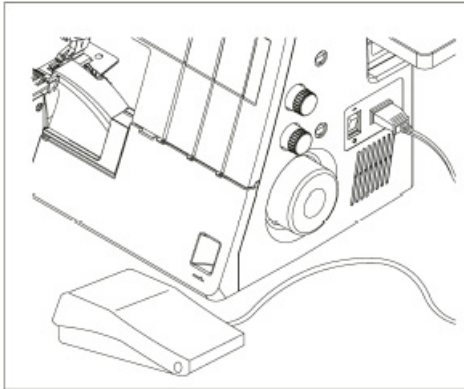

Achtung: Stellen Sie sicher, dass das Gerät ausgesteckt ist und sich der Netzschalter in der Position „0“ befindet, wenn das Gerät nicht verwendet wird und bevor Sie Teile austauschen oder bewegen. Anschließen der Stromversorgung

Bevor Sie das Netzkabel an das Stromnetz anschließen, vergewissern Sie sich, dass die auf dem Gerät angegebene Spannung mit der Netzspannung übereinstimmt.

Stellen Sie das Gerät auf eine stabile Oberfläche.

1. Stecken Sie den Stecker des Geräts in die Steckdose.
2. Stecken Sie den Netzstecker in eine Steckdose.
3. Schalten Sie das Gerät ein.
4. Die Beleuchtungslampe für den Arbeitsbereich schaltet sich ein, wenn das Gerät eingeschaltet wird

Um das Gerät auszuschalten, schieben Sie den Netzschalter auf die Position „0“ und ziehen Sie dann den Stecker aus dem Anschluss.

STARTEN SIE ZU NÄHEN



Schalten Sie das Gerät aus und schließen Sie das Gerät an das Gerät an.

Stecken Sie den Netzstecker in eine Steckdose.

Die Nähgeschwindigkeit wird durch das Fußpedal gesteuert. Je stärker Sie auf das Pedal treten, desto schneller läuft die Maschine. Heben Sie den Nähfuß an, treten Sie auf den Fußanlasser und üben Sie das Arbeiten mit verschiedenen Geschwindigkeiten.

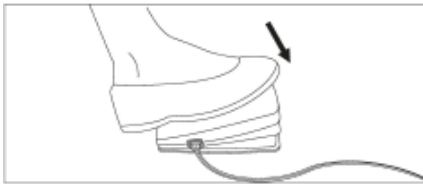

Zu Ihrer Sicherheit:

- Schauen Sie beim Nähen immer auf den Nähbereich. Berühren Sie keine beweglichen Teile der Maschine wie Fadenführung, Greifer, Handrad, Nadel, Messer.
- Schalten Sie die Stromversorgung immer aus, wenn:
 - die Maschine unbeaufsichtigt lassen
 - Teile wechseln oder hinzufügen
 - Maschine einfädeln oder reinigen
- Legen Sie nichts auf den Fußanlasser, insbesondere wenn die Maschine läuft.

EINSTELLEN DES NÄHFUSSDRUCKS

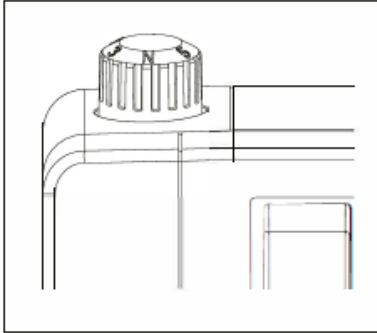

Beim normalen Nähen ist es nicht erforderlich, den Druck des Nähfußes auf den Stoff zu ändern.

Wenn Sie verschiedene Stoffe nähen, drehen Sie die Einstellschraube entsprechend dem Stoff.

In diesem Fall gibt es sechs Positionen zur Auswahl. Standardnähfuß «N».

△ Hinweis:

Heben Sie immer den Nähfuß an, bevor Sie die Maschine einfädeln.

EINFÄDELN DER FADENFÜHRUNGEN

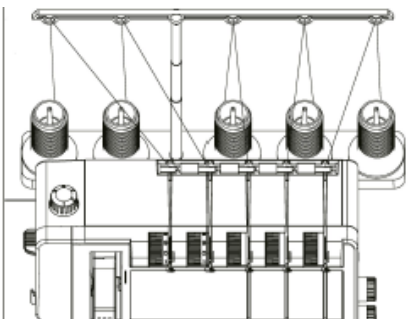

ACHTUNG: Schalten Sie die Maschine vor dem Einfädeln aus und ziehen Sie den Netzstecker.

Fädeln Sie die Maschine in der folgenden Reihenfolge ein:

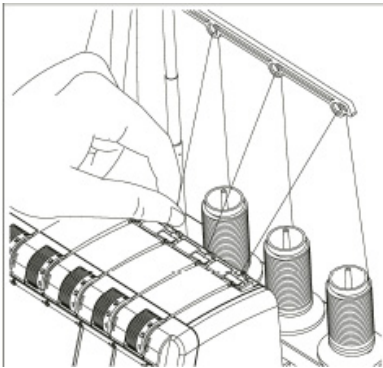

1) Linken Greifer einfädeln

2) Rechter Greiferfaden

3) Linker Nadelfaden

4) Rechter Nadelfaden

Heben Sie den Nähfußhebel an.

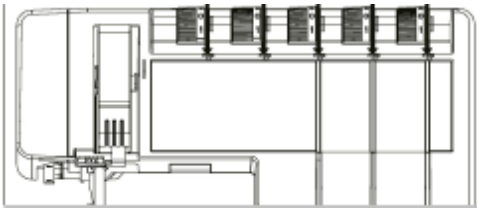

Einfädelreihenfolge

EINFÄDELN DES RECHTEN (OBEREN) GREIFERS

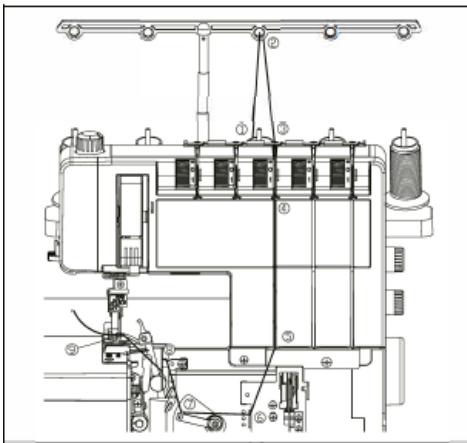

Drehen Sie das andrad in Ihre Richtung, bis der Greifer in seine höchste Position angehoben wird.

A - oberer Greifer

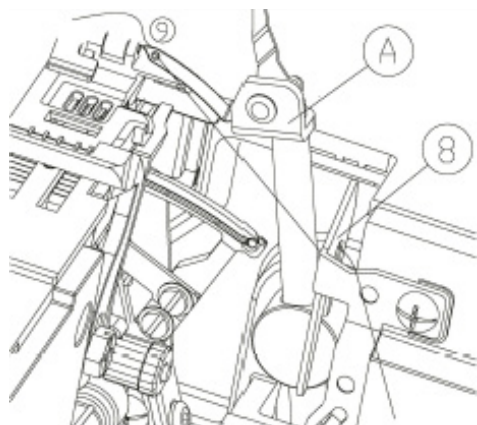

Fädeln Sie den Faden von Schritt 1 bis Schritt 7 durch die Fadenführungen.

Führen Sie den Faden von oben über die Fadenführung 8 und ziehen Sie ihn nach unten und nach links, bis er in die Führungsgabel eintritt.

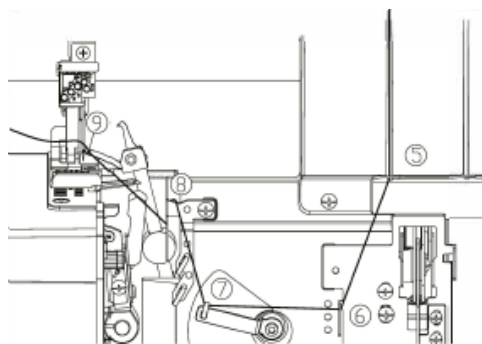

Schieben Sie den Greifer 9 gerade von sich weg.

Ziehen Sie 10 cm Faden heraus und führen Sie ihn unter den Nähfuß.

EINFÄDELN DES LINKEN (UNTEREN) GREIFERS

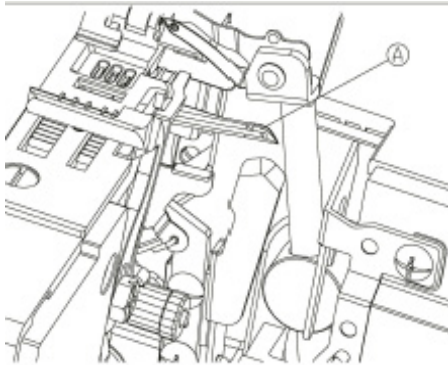

Drehen Sie das Handrad in Ihre Richtung, bis sich der Greifer ganz rechts befindet.

A - unterer Greifer

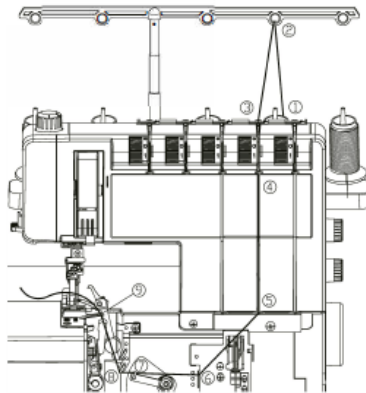

Fädeln Sie den Faden von Schritt 1 bis 9 durch die Fadenführungen.

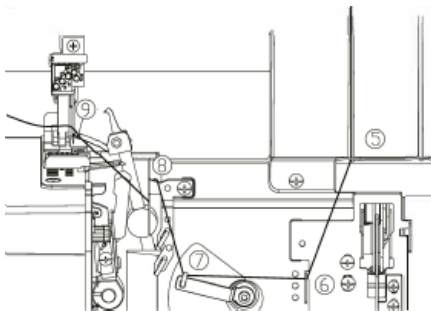

Senken Sie den Hebel (a) und legen Sie den Faden auf die Fadenführung (b).

Fädeln Sie den Faden von sich weg in die Öse (c) am rechten Ende des Greifers

Ziehen Sie 10 cm Faden heraus und führen Sie ihn unter den Fuß.

NAHTGREIFER FÜR CARPETLOCK EINFÄDELN (COVER-UND ABSTEEPSTICHE)

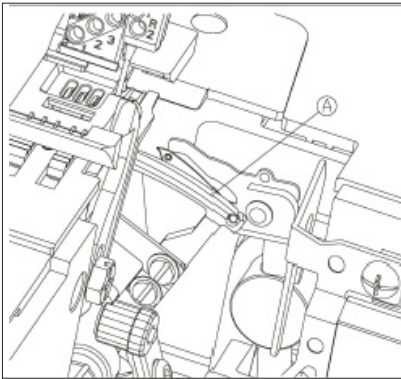

Handrad drehen, bis sich der Nähgreifer ganz rechts befindet

A - Nähgreifer

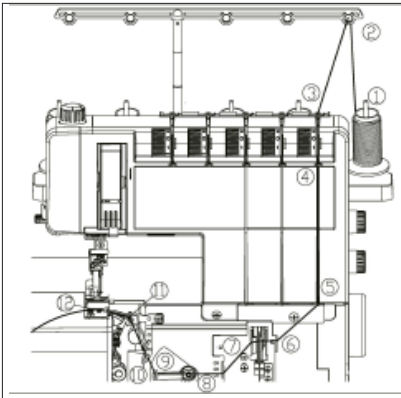

Fädeln Sie den Faden von Schritt 1 bis 12 durch die Fadenführung.

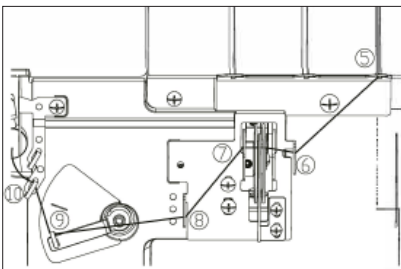

△ Hinweis:

Beim Einfädeln der Artikel 6 und 7 wird der Faden einfach aufgelegt und nicht durchgesteckt.

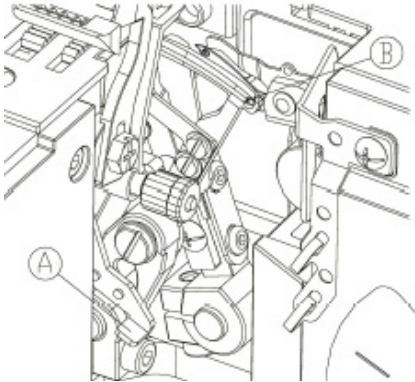

Heben Sie den Hebel (A) an und fädeln Sie den Schnitt ein (B)

△ Hinweis:

Der Hebel kehrt in seine ursprüngliche Position zurück, sobald Sie mit dem Nähen beginnen.

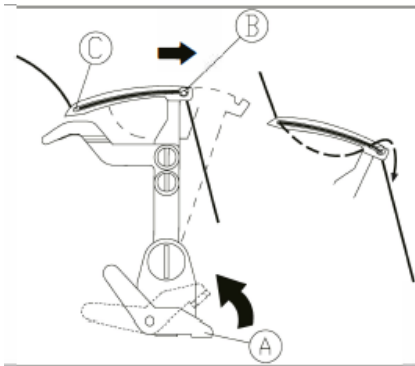

Führen Sie den Faden von sich weg durch die Greiferöse (C).

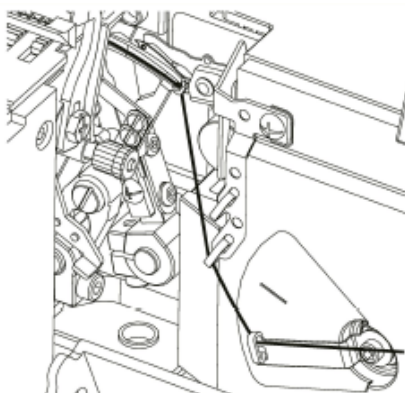

10 cm Faden herausziehen und unter den Nähfuß ziehen.

NADELEINFÄDELN

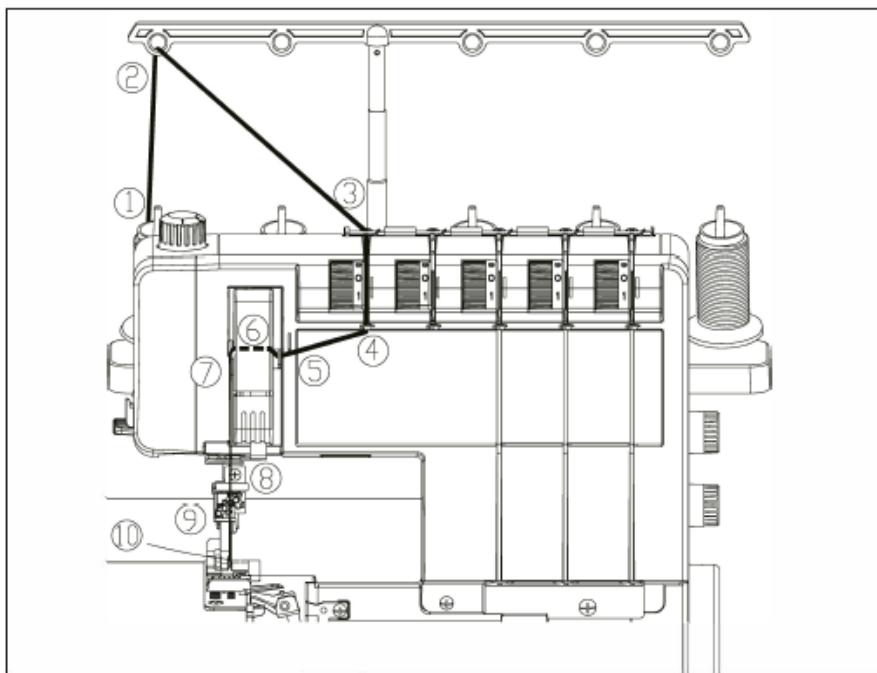

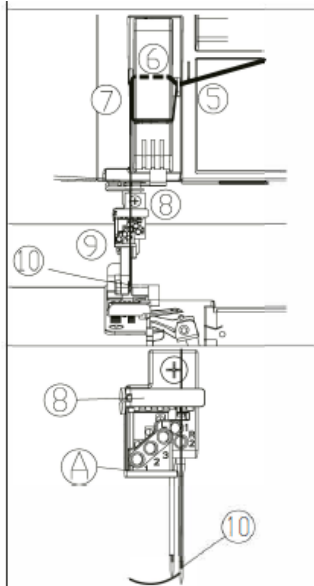

Fädeln Sie die Fäden von Punkt 1 bis Punkt 10 ein.

Der Faden sollte durch die untere Kerbe der Fadenführung gehen 5

Ziehen Sie 10 cm Faden heraus und ziehen Sie ihn unter den Nähfuß.

Wenn Sie mit den Nadeln L1, L2 oder L3 nähen, müssen Sie die Fadenführung A verwenden.

(A) - Fadenführung EIN

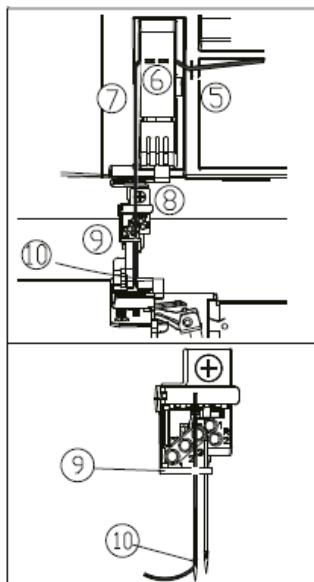

Ausnahme: Fädeln Sie Nadel L3 beim Nähen mit 5-Faden-Overlockstich ein (Stich 20) und beim Nähen mit 4-Faden-Overlockstich (Stich 19) und 2-x mit dem Nähstich { {1}} (Stich 04) Fädeln Sie in der Reihenfolge von Schritt 1 bis 10 ein.

△ Hinweis:

Beim Einfädeln des Nähgreifers (Stich 04) müssen Sie die Fadenspannung grün einfädeln

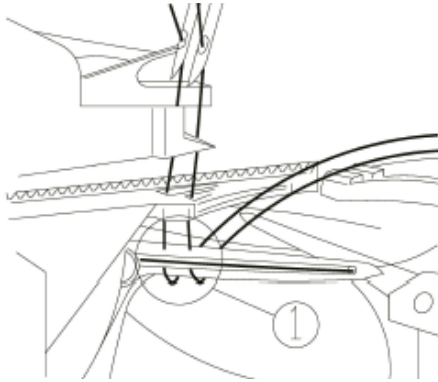
**Wichtig beim Einfädeln der Nadeln:**

Fädeln Sie die Nadeln immer zuletzt ein, damit sich die Nadeln nicht in den Greiferfäden verfangen, wie in Abb. 1. Sie sollten sich aber über den Greiferfäden befinden, wie in Abb. 2. Andernfalls können die Fäden reißen.

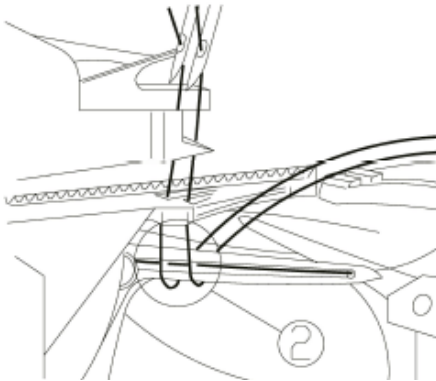

Wenn die Greiferfäden gerissen sind sollten Sie die Fäden von den Nadeln entfernen, die Greifer einfädeln und dann die Nadeln einfädeln.

MANUELLER NADELEINFÄDLER

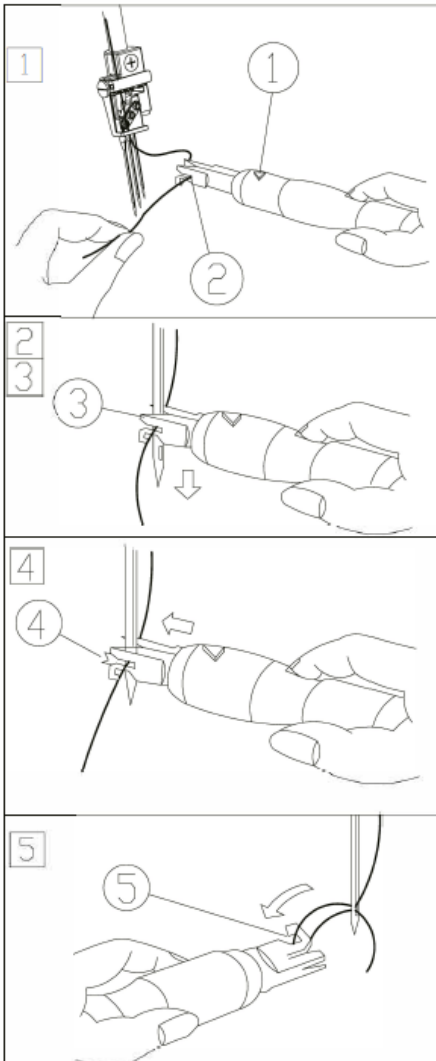

! SCHALTEN SIE DIE MASCHINE AUS!

Heben Sie die Nadeln in ihre höchste Position und senken Sie den Nähfuß.

Führen Sie den Faden von rechts nach links in die Kerbe des Nadeleinfädlers A ein.

Einer der zwei Dreiecksmarkierungen sollten nach oben zeigen {{1}} Platzieren Sie den Einfädler vor der vorderen Rille der Nadel, berühren Sie ihn und senken Sie ihn bis zum Nadelöhr ab und schieben Sie den Einfädler vorsichtig durch das Öhr. Ein kleiner Metallstift geht durch das Nadelöhr und fädelt die Nadel automatisch ein.

Verwenden Sie nun Haken 5, um das Knopfloch durch die Öse zu ziehen.

△ Hinweis:

Wenn Sie zu fest drücken, kann sich der kleine Metallstift verbiegen. Und der Einfädler wird versagen.

ALLGEMEINES THREADING-SCHEMA FÜR ALLE ARTEN VON PROGRAMMEN

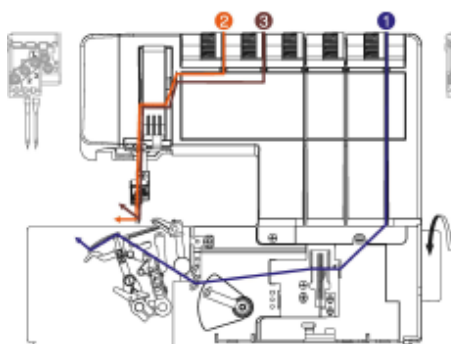

Programm 01
2-Nadel-Coverstich schmal (L2 / L3).

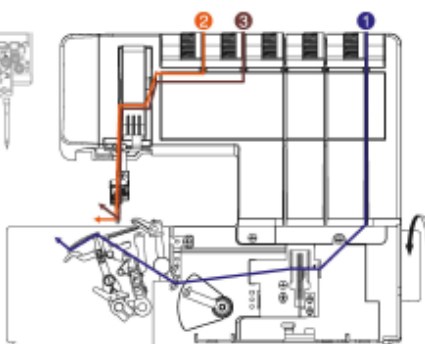

Programm 02
2-Nadel-Coverstich breit (L1 / L3).

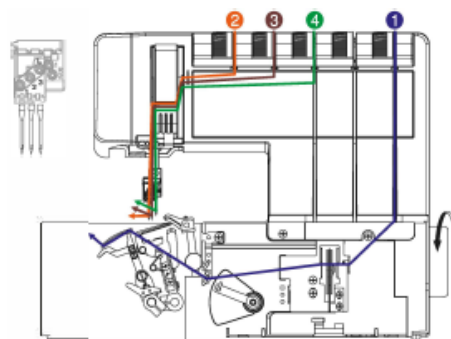

Programm 03
2-Nadel-Coverstich (L1 / L2 / L3)

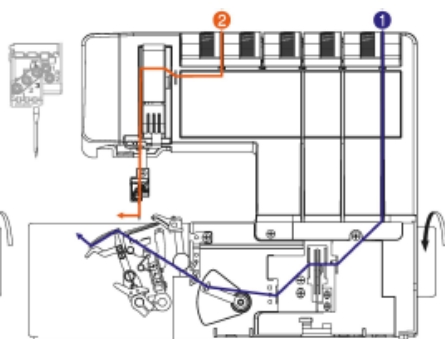

Programm 04
Nahtstich (L3) (Einnadel-Kettenstich).

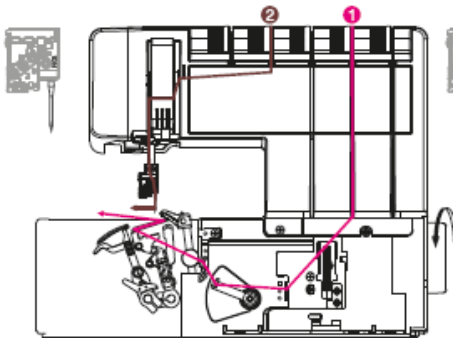

Programm 05
2-Faden FlatLock-Schmalstich (R2).

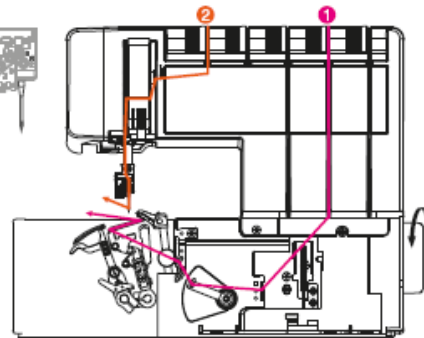

Programm 06
2-Faden FlatLock-Stich, breit (R1).

Programm 07
2-Faden-Überwindling, schmal (R2).

Programm 08
2-Faden-Flachrollenstich (R2).

Programm 09
2-Faden-Rollenstich (R2).

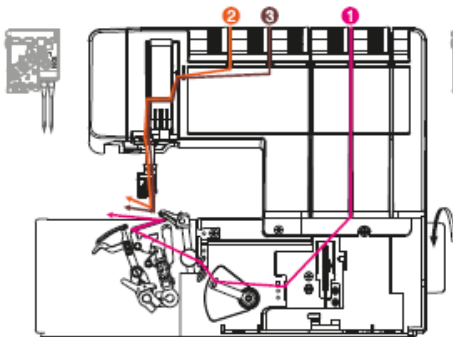

Programm 10
2-Nadel, 3-Faden-Overlockstich (R1
/ R2)

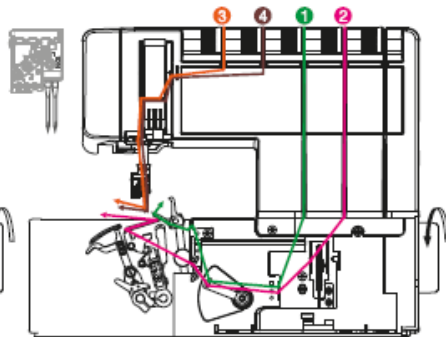

Programm 11
2-Nadel, 3-Faden-Overlockstich (R1
/ R2)

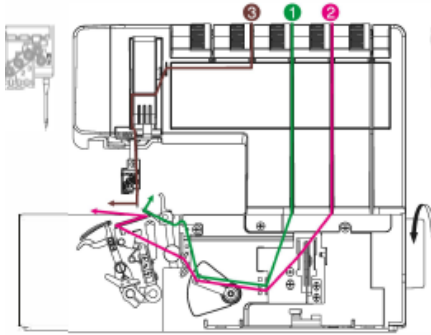

Programm 12
2-Faden-Overlock-Schmalstich (R2)

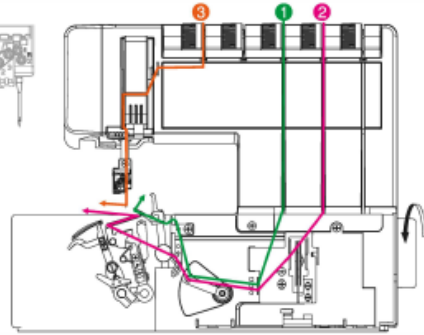

Programm 13
3-Faden-Overlockstich, breit (R1)

Programm 15
3-Faden-FlatLock-Stich, schmal (R2)

Programm 14
3-Faden-Überwendling, schmal (R1)

Programm 17
3-Faden-Flachrollenstich (R2)

Programm 16
3-Faden-FlatLock-Stich, breit (R1)

Programm 18
3-Faden-Rollsaum (R2)

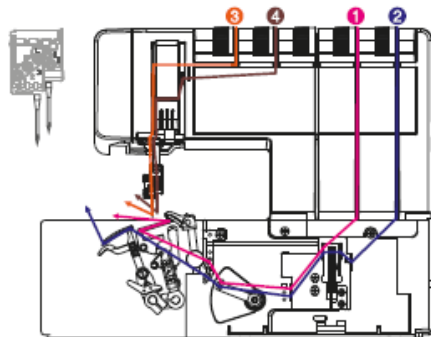

Programm 19
4-Faden-Überwendling, Stich, breit
(L3 / R1)

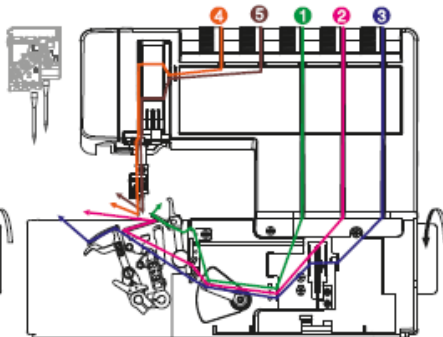

Programm 20
5-Faden-Overlockstich, breit (L3 /
R1)

EINGEBAUTER FADENABSCHNEIDER

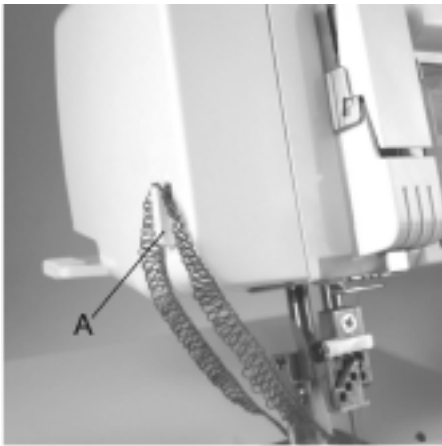

Lassen Sie am Ende der Naht eine 15-20 cm lange Fadenskette und ziehen Sie diese bis zum Fadenabschneidemesser. Dadurch wird der Faden abgeschnitten.

A - Fadenabschneider



Legen Sie den Stoff direkt vor die Nadeln. Schneiden Sie bei Bedarf mit einer Schere 3 cm entlang der Stoffkante ab. Senken Sie den Fuß und beginnen Sie mit dem Nähen. Der Stich wird automatisch entlang des Schnitts genäht.

△ Hinweis:

Diese Methode eignet sich für Coverstiche.



Bringen Sie den Abfallbehälter an der vorderen Abdeckung der Greifer an. Stoffreste fallen hinein.

TRENNEN DES OBERMESSERS

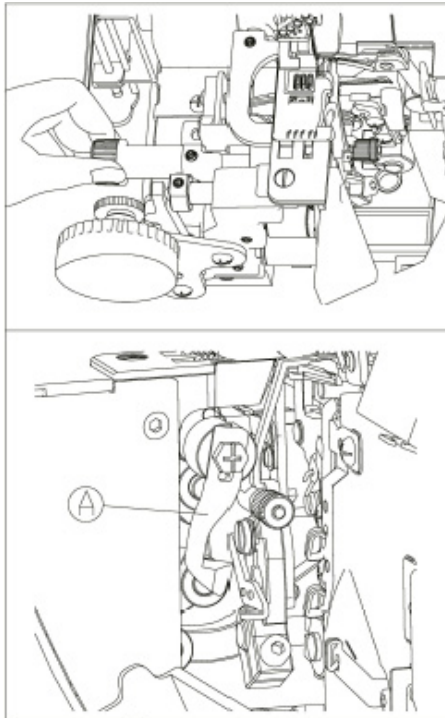

! MASCHINE AUSCHALTEN!

Entfernen Sie den Schneidekasten und öffnen Sie die vordere Greiferabdeckung und die linke Abdeckung der Plattform.

Heben Sie das Obermesser durch Drehen des Handrads in seine höchste Position an. Drücken Sie nun den Obermesser-Abschneidegriff ganz nach rechts.

A - Obermesser

Drehen Sie den Griff zu sich, bis das Obermesser unten ist. Das Messer ist deaktiviert.

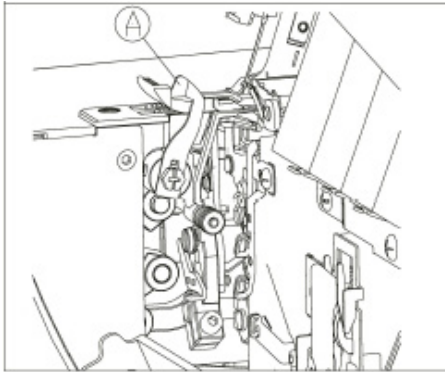
Obermesser einschalten

Schieben Sie den Griff ganz nach rechts und drehen Sie ihn von sich weg, bis er klickt. Das Messer fährt wieder in seine Arbeitsposition. Schließen Sie die Greiferabdeckung und die linke Plattformabdeckung. Setzen Sie den Schneidebehälter wieder ein.

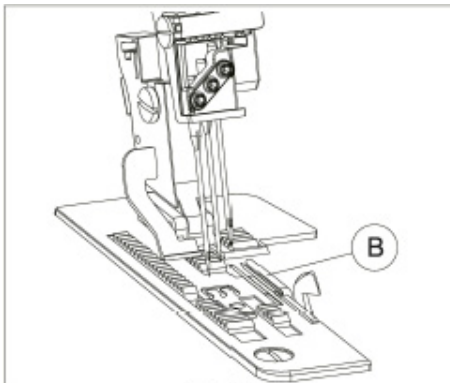
ABKOPPELN DES STREUERS

Für Standard-Overlockstiche.
Um mit allen Standard-Overlockstichen (Programme 02, 04) zu nähen, kehrt der Schlingenfinger in seine ursprüngliche Position zurück

A - Schlingenfinger vom Knopf

B - Schlingenfinger.

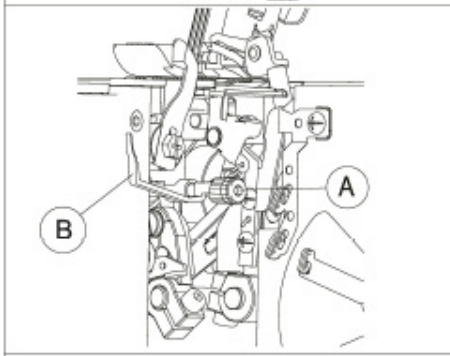

Für Rollstiche

Entfernen Sie den Schneidekasten und öffnen Sie die vordere Greiferabdeckung. Ziehen Sie den Griff A nach rechts und senken Sie den Schlaufenstift in seine Ruhestellung ab, indem Sie den Griff zu sich hindrehen.

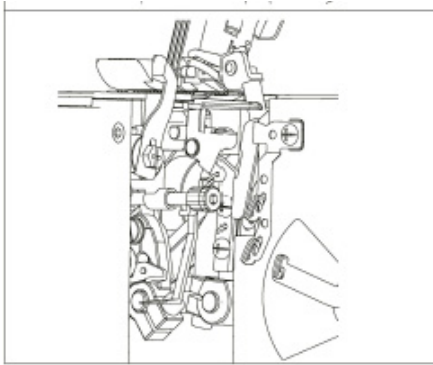

Mit dieser Einstellung können Sie alle Rollstiche nähen.
Auch Abdeck- und Zierstiche.
(Programme 02, 04)

RECHTER (OBERER) KNOPFLOCHKONVERTER

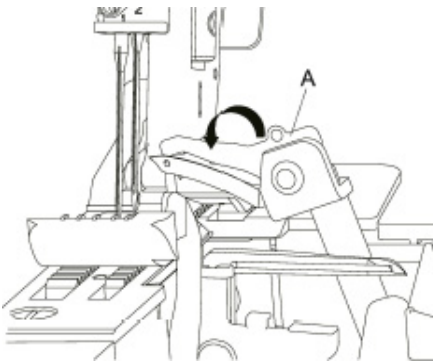

Aktiviert den 2-Thread-Konverter: Drehen Sie das Handrad, bis der rechte (obere) Greifer in seine höchste Position gehoben ist.

Senken Sie den Konverter ab und führen Sie seinen Haken in die Greiferöse ein.

A - 2-Faden-Konverter

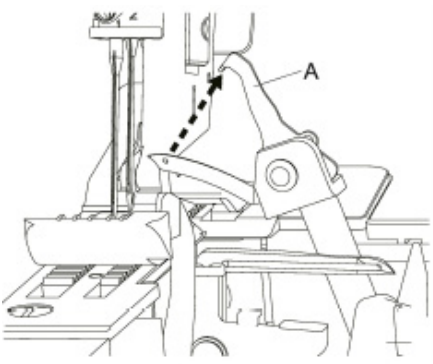

Abschaltung des 2-Thread-Konverters: Drehen Sie das Handrad, bis der rechte (obere) Greifer in die oberste Position steigt. Entfernen Sie den Haken des Konverters aus der Öse des Greifers und heben Sie den Konverter in seine ursprüngliche Position (oben rechts) an. Deaktivieren Sie den oberen rechten Greifer.

DEAKTIVIEREN DES RECHTEN (OBEREN) GREIFERS

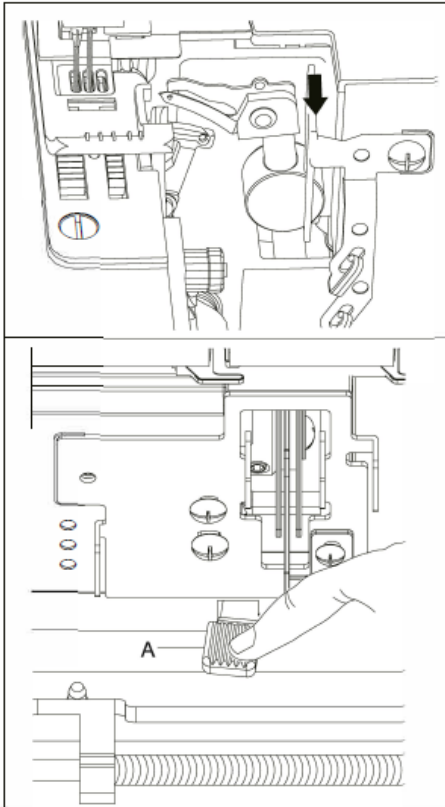

Deaktivieren des rechten (oberen) Greifers Zum Nähen von Deck- und Oberstichen deaktivieren Sie den rechten (oberen). Greifer mit dem Deaktivierungshebel.

Entfernen Sie den Abfallbehälter und öffnen Sie die vordere Greiferabdeckung. Handrad drehen, bis der Greifer in die unterste Position abgesenkt ist.

A - Rechter (oberer) Greifer-Ausrückhebel.

Drücken Sie den Greiferfreigabehebel nach unten und schieben Sie ihn nach links. Drehen Sie das Handrad, um sicherzustellen, dass sich der Greifer nicht bewegt.

Um den oberen rechten Greifer zu aktivieren, drücken Sie den Greiferfreigabehebel und bringen Sie ihn in seine ursprüngliche Position zurück. Drehen Sie das Handrad, bis der Greifer nach oben klickt.

Schließen Sie die Frontabdeckung und setzen Sie den Abfallbehälter wieder ein.

EINSTELLEN DER STICHLÄNGE UND DES DIFFERENTIALTRANSPORTS

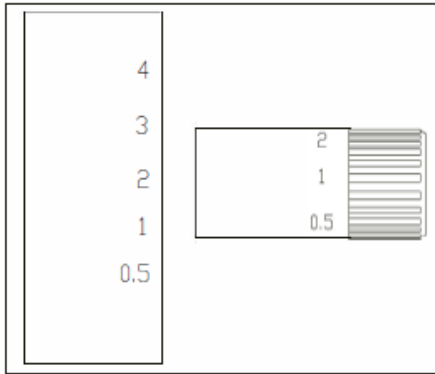

Drehen Sie das Stichlängen-Einstellrad, um die gewünschte Stichlänge auszuwählen.

Die Stichlänge kann von 0,5 bis 4 eingestellt werden.

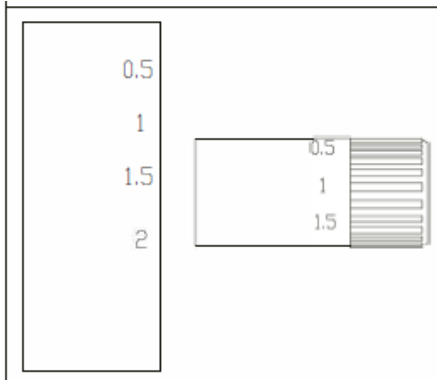

Drehen Sie das Einstellrad für den.

Differentialtransport, um das gewünschte Verhältnis auszuwählen.

Der Differentialtransport kann von 0,5 bis 2 eingestellt werden.

ERSETZEN DES OBEREN EINSATZES DER GREIFERABDECKUNG

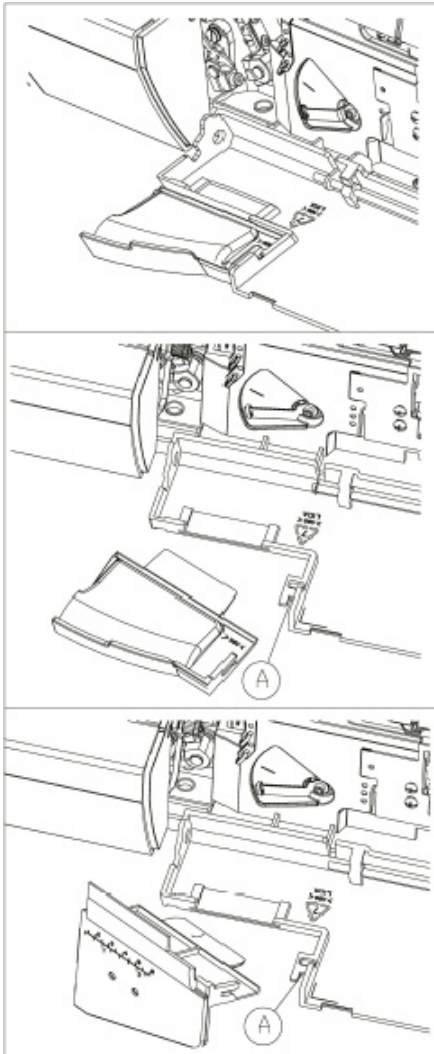

Entfernen Sie den Abfallbehälter und öffnen Sie die Greiferabdeckung. Ziehen Sie den Greiferabdeckungseinsatz nach oben heraus.

Um den horizontalen Deckstich in das vordere Deckblatt einzufügen, platzieren Sie es unter Riegel A.

Und drücken Sie entlang der Führungen des vorderen Deckblatts.

△ Hinweis:

Die horizontale Plattform ist mit Messrisiken gekennzeichnet. Die oberen Markierungen sind in Zentimetern und die unteren Markierungen in Zoll.

EINSTELLEN DER SCHNITTBREITE DES STOFFES

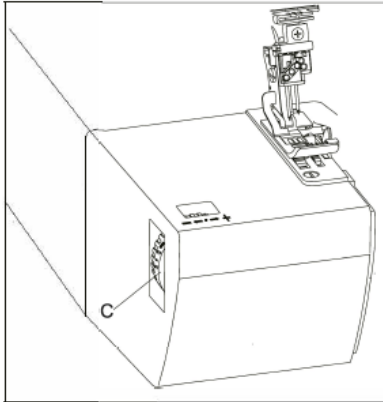

Einstellen der Schnittbreite des Stoffes Drehen Sie den Schnittbreiteneinstellknopf, um zwischen 3,5 und 6,0 mm auszuwählen

Hinweis: Der Kettennahstich wird von 0,5 bis 9 genäht.

C: Einstellknopf für die Stoffzuschneidebreite.



Abb A. Und wenn die Schlaufen über den Stoffschnitt hinausragen, drehen Sie den Einstellknopf, um das Messer nach oben zu bewegen, um das Messer nach rechts zu bewegen.



Abb. B, wenn Knopflöcher den Stoffschnitt enger machen, drehen Sie den Einstellknopf nach unten, um das Messer nach links zu bewegen

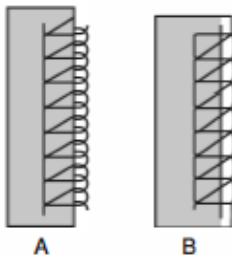

△ Hinweis:

Die Schnittbreiteneinstellung von 4,8 mm bis 5,0 mm ist nur für die R1 wichtig Nadel... Bei Verwendung der R2-Nadel verringert sich dieser Wert um 2 mm.

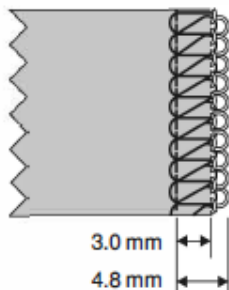
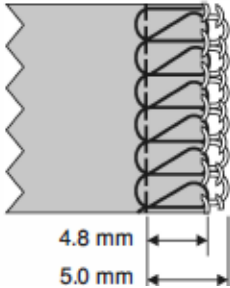
ANBRINGEN DES LINEALS

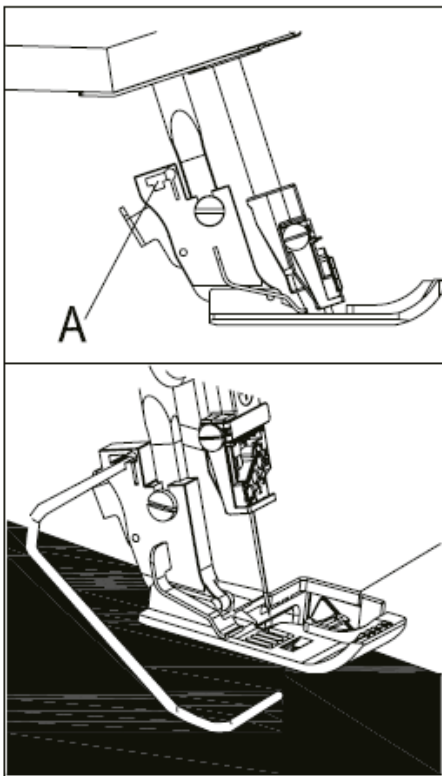

! SCHALTEN SIE DIE MASCHINE AUS!

Führen Sie die mitgelieferte Näh- und Quiltführung von links nach rechts in den Schlitz A des Fußhalters ein.

Sie können das Lineal einstellen nach Belieben in der Fußhalterung nach rechts / links schieben.

Sie können diese Einstellungen für alle Rollstiche verwenden.

ERSETZEN DES OBERMESSERS

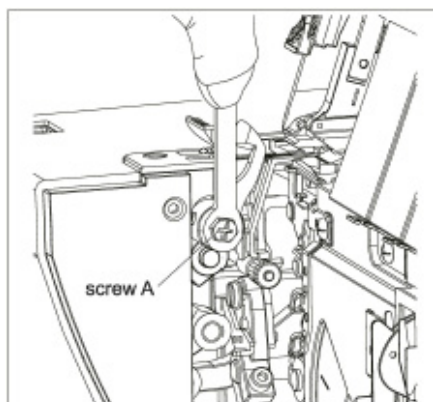

Entfernen des Messers: Stellen Sie das Schnittbreitenrad auf 3,5 mm ein. Schraube A mit dem im Set mitgelieferten Schlüssel lösen. Und entfernen Sie das obere Messer.

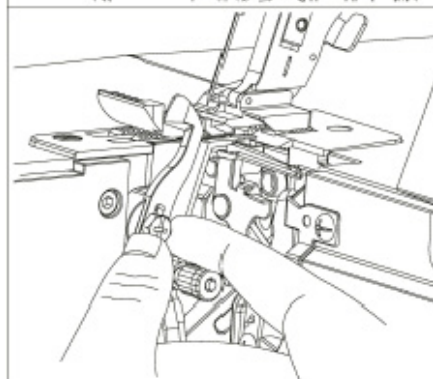

Messer einbauen : Obermesser montieren und Schraube A leicht anziehen. Handrad drehen, bis Obermesser in unterster Stellung steht.

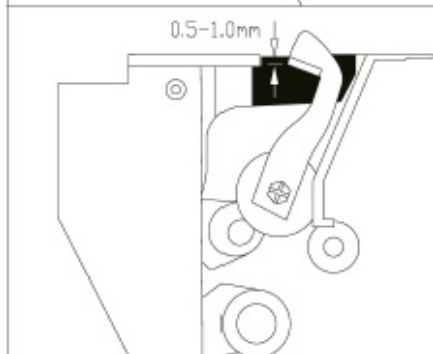

In der unteren Position sollte sich das vordere Ende des Obermessers 1 mm unter dem Untermesser befinden, wenn Sie das Obermesser korrekt montiert haben. Schraube A vollständig festziehen.

PFLEGE DES GERÄTS

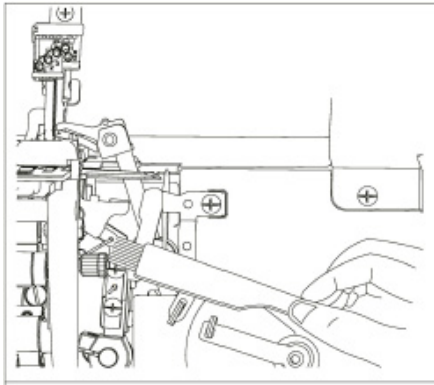

! SCHALTEN SIE DAS GERÄT AUS!

Reinigen des Geräts.

Entfernen Sie den Abfallbehälter. Öffnen Sie die obere reiferabdeckung und die linke Plattformabdeckung. Trennen Sie das Obermesser. Entfernen Sie den Nähfuß und die Stichplatte.

Entfernen Sie mit einer Bürste aus dem Zubehörset Staub und Vlies von Ober- und Untermesser, Zahnstangen und Greiferbereich.

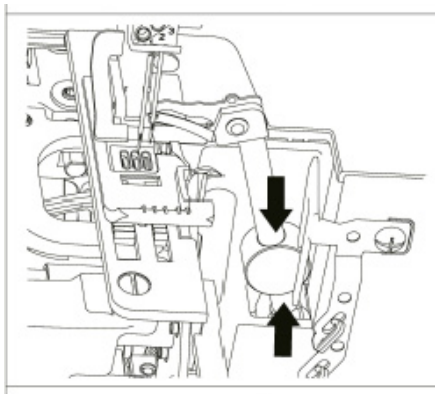

Maschine schmieren .

Durch Drehen des Handrads den rechten (oberen) Greifer in die oberste Position bringen. Schmieren Sie nach jeder Reinigung der Maschine den durch die Pfeile in der Abbildung gekennzeichneten Bereich. Ein Tropfen Öl genügt.

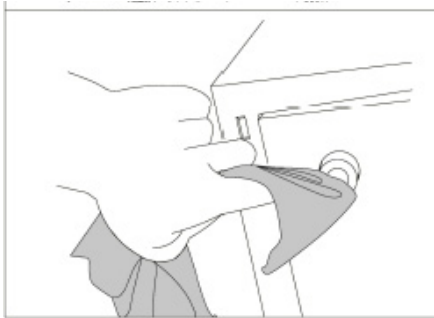
**Reinigen der GummifüÙe .**

Reinigen Sie die GummifüÙe im Laufe der Zeit mit Methylalkohol. Dadurch wird verhindert, dass sich die Maschine während des Nähens bewegt.

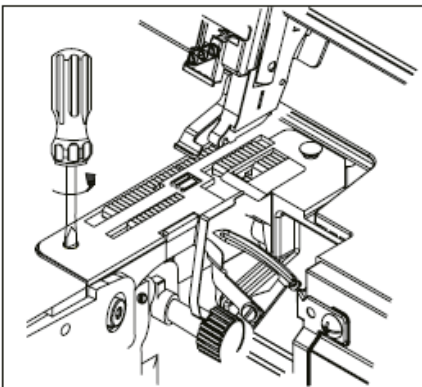
**Stichplatte entfernen.**

Nehmen Sie die Nadeln heraus, entfernen Sie den Nähfuß und den Fußhalter.

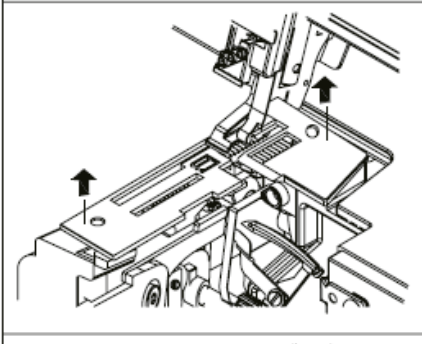



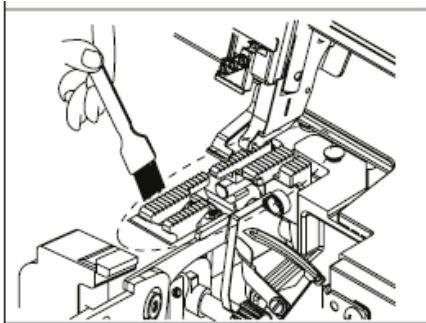





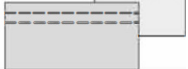
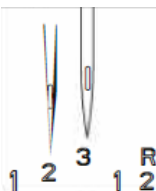

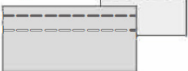

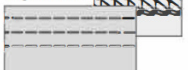

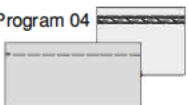

Lösen Sie die Schrauben, mit denen die Stichplatte befestigt ist, und entfernen Sie die Stichplatte.



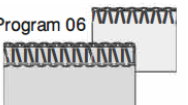







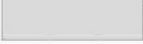





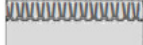

Reinigen Sie den Bereich der Greifer, Transporteur mit einer Bürste aus dem Zubehörset.

NÄHEN, NÄHEN UND TEPPICHSTICH, BEISPIELE FÜR EINSTELLUNGEN





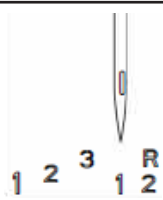
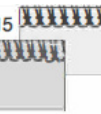
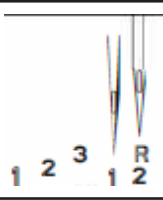

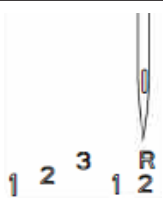
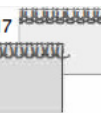
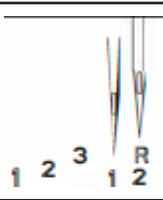
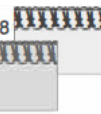
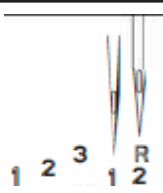

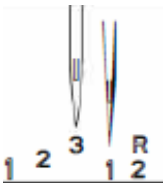
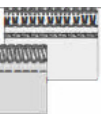
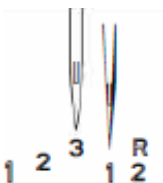

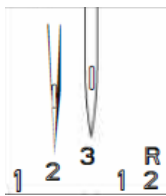

Programme	Nadelposition	Stichlänge	Stichbreite	Fadenspannung
Program 01  		2.5	5.0	<input type="text" value="5.0"/> <input type="text" value="5.0"/> _ _ <input type="text" value="1.0"/>
Program 02  		3.0	5.0	<input type="text" value="5.0"/> <input type="text" value="5.0"/> _ _ <input type="text" value="1.0"/>
Program 03  		3.0	5.0	<input type="text" value="5.0"/> <input type="text" value="4.5"/> <input type="text" value="5.0"/> _ <input type="text" value="1.0"/>



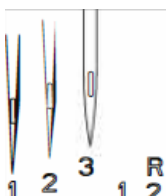

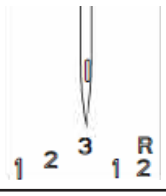

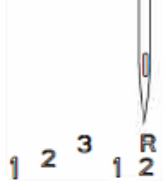



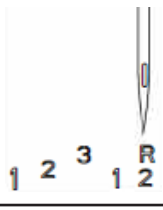

Programme	Nadelposition	Stichlänge	Stichbreite	Fadenspannung
Program 04 	 1 2 3 1 R 2	3.0	5.0	<input type="text" value="3.0"/> _ _ _ <input type="text" value="1.5"/>
Program 05 	 1 2 3 1 R 2	2.0	5.5	_ <input type="text" value="1.5"/> _ <input type="text" value="6.0"/> _
Program 06 	 1 2 3 1 R 2	2.0	5.5	<input type="text" value="1.5"/> _ _ <input type="text" value="6.0"/> _
Program 07 	 1 2 3 1 R 2	2.0	5.5	_ <input type="text" value="5.0"/> _ <input type="text" value="2.5"/> _
Program 08 	 1 2 3 1 R 2	1.0	5.5	_ <input type="text" value="1.5"/> _ <input type="text" value="5.0"/> _





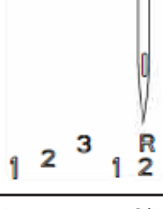

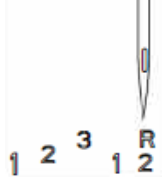

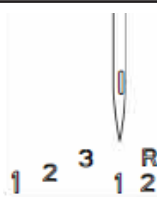

Programme	Nadelposition	Stichlänge	Stichbreite	Fadenspannung
Program 09  	 1 2 3 1 2 R	1.0	5.5	_ <input type="text" value="3.0"/> _ <input type="text" value="3.0"/> _
Program 10  	 1 2 3 1 2 R	2.0	5.5	_ <input type="text" value="3.5"/> <input type="text" value="3.5"/> <input type="text" value="2.5"/> _
Program 11  	 1 2 3 1 2 R	2.0	5.5	<input type="text" value="3.0"/> _ <input type="text" value="1.0"/> <input type="text" value="1.0"/> _
Program 12  	 1 2 3 1 2 R	2.0	5.5	<input type="text" value="4.5"/> _ <input type="text" value="0.5"/> <input type="text" value="7.5"/> _
Program 13  	 1 2 3 1 2 R	1.0	5.5	_ <input type="text" value="0.5"/> <input type="text" value="3.0"/> <input type="text" value="6.0"/> _

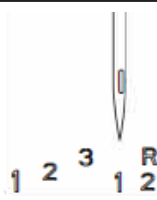

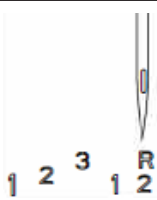

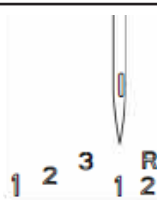

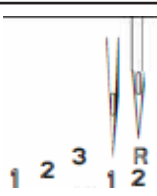

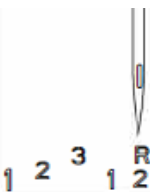

Programme	Nadelposition	Stichlänge	Stichbreite	Fadenspannung
Program 14 		2.0	5.5	<input type="text" value="0.5"/> _ <input type="text" value="2.5"/> <input type="text" value="7.0"/> _
Program 15 		2.0	5.5	<input type="text" value="4.0"/> <input type="text" value="2.0"/> _ <input type="text" value="1.0"/> _
Program 16 		1.0	5.5	_ <input type="text" value="2.5"/> <input type="text" value="3.5"/> <input type="text" value="2.0"/> _
Program 17 		1.0	5.5	_ <input type="text" value="3.0"/> <input type="text" value="2.0"/> <input type="text" value="6.0"/> _
Program 18 		2.5	5.5	<input type="text" value="3.5"/> <input type="text" value="2.0"/> <input type="text" value="2.0"/> <input type="text" value="1.5"/> _

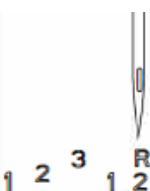
Programme	Nadelposition	Stichlänge	Stichbreite	Fadenspannung
Program 19 		2.5	8.0	<input type="text" value="3.0"/> <input type="text" value="0.5"/> _ <input type="text" value="4.0"/> <input type="text" value="1.5"/>
Program 20 		3.0	8.5	<input type="text" value="3.0"/> <input type="text" value="2.5"/> <input type="text" value="1.0"/> <input type="text" value="1.0"/> <input type="text" value="1.5"/>

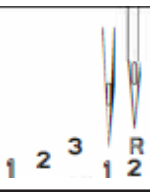
Nadelposition	Stichlänge	Stichbreite	Differenzial-transport	Obermesser	Obergreifer	Konverter 2-thread	Schlingenfinger
	2.5	5.0	1.0	X			X
	3.0	5.0	1.0	X			X
	3.0	5.0	1.0	X			X
	3.0	5.0	1.0	X			X
	2.0	5.5	1.0	V			V

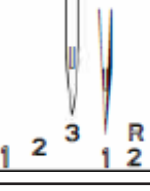
Nadelposition	Stichlänge	Stichbreite	Differenzial-transport	Obermesser	Obergreifer	Konverter 2-thread	Schlingenfinger
	2.0	5.5	1.0	V			V
	2.0	5.5	1.0	V			V
	1.0	5.5	1.0	V			X
	1.0	5.5	1.0	V			X
	2.0	5.5	1.0	V			V

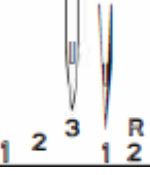
Nadelposition	Stichlänge	Stichbreite	Differenzial-transport	Obermesser	Obergreifer	Konverter 2-thread	Schlingenfinger
	3.0	5.5	1.0	V			V
	2.0	5.0	1.0	V			V
	2.0	5.5	1.0	V			V
	2.0	5.5	1.0	V			V
	2.0	5.5	1.0	V			V

Nadelposition	Stichlänge	Stichbreite	Differenzial-transport	Obermesser	Obergreifer	Konverter 2-thread	Schlingenfinger
	1.0	5.5	1.0	V			X
	1.0	5.5	1.0	V			X
	2.5	5.5	1.0	V			X
	2.5	8.0	1.0	V			X
	3.0	8.5	1.0	V			V

PRECAUZIONI D'USO

Prima di adoperare la macchina si prega di leggere questo manuale.

Non usare la macchina alla temperatura d'ambiente superiore a 45°C o inferiore a 5°C, nei locali con umidità elevata oppure all'aria aperta, altrimenti la macchina può funzionare scorrettamente. Per evitare la formazione della condensa sulle parti elettroniche si sconsiglia di accendere la macchina subito dopo lo spostamento dalla zona aperta all'interno.

Bisogna aspettare che la macchina raggiunga la temperatura d'ambiente. Si sconsiglia di usare la macchina nelle condizioni di funzionamento non stabile della rete elettrica oppure nei posti con campo elettrico o magnetico forte, altrimenti la macchina funzionerà con interruzioni. Bisogna posizionare la macchina su una superficie liscia e stabile considerando la distanza necessaria fino agli oggetti immobili.

Non lasciare cadere la macchina il che può provocare traumi e danneggiare la macchina.

L'USO DELLA MACCHINA

Bisogna essere attenti durante l'uso della macchina, non mettere le mani nella zona di funzionamento delle parti mobili, soprattutto nel campo di funzionamento degli aghi. Per evitare una scossa elettrica oppure un cortocircuito assicurarsi che tutti i cavi siano in buono stato e che non siano danneggiati (privi di tagli, bruciature ecc.) e non siano a contatto con ambienti umidi o aggressivi. Il cavo di alimentazione deve avere un contatto sicuro con la rete elettrica. Per staccare il cavo di alimentazione dalla rete non tirare il cavo.

SI REGA DI CONSERVARE IL PRESENTE MANUALE

Questa macchina e' destinata esclusivamente al uso domestico.

Questa macchina non e' destinata per l'uso da parte delle persone (compreso bambini) con disabilita' fisiche o mentali oppure da quelle non aventi conoscenze e pratiche sufficienti salvo i casi quando sono controllate o addestrate dalle persone responsabili per la loro sicurezza. E' richiesta una prudenza se la macchina viene usata nelle vicinanze di bambini, non permettere che i bambini giochino con la macchina.

A condizione dell'osservanza delle condizioni di esercizio e di conservazione della macchina la sua vita utile durera' non meno di 8 anni.

CONOSCERE LA MACCHINA

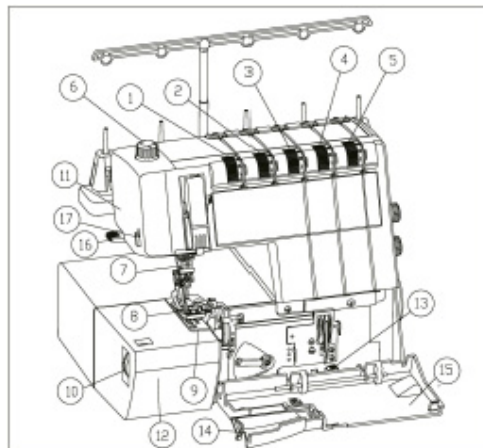

1. Regolatore tensione filo dell'ago
2. Regolatore tensione filo dell'ago
3. Regolatore tensione filo del crochet superiore
4. Regolatore tensione filo del crochet superiore
5. Regolatore tensione filo del crochet della catenella
6. Regolatore pressione del piedino

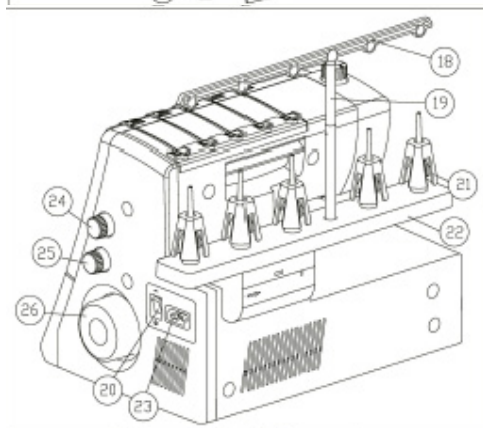

7. Morsetto degli aghi
8. Piedino standard
9. Placca d'ago
10. Regolatore larghezza soprappitto
11. Coperchio della lampadina
12. Coperchio sinistro del piano di cucito

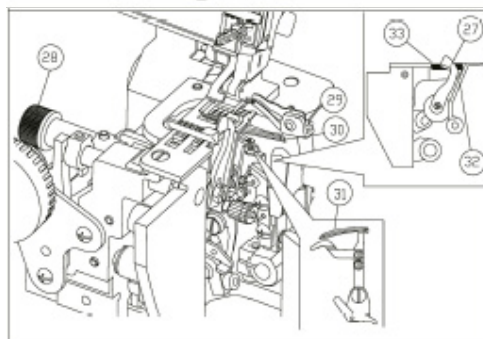

13. Leva disattivazione del crochet
14. Inserto superiore del coperchio
15. Coperchio dei crochet
16. Leva alzapiedino
17. Coltello taglia filo

- 18.Sbarra guidafili
 - 19.Asta guidafile telescopica
 - 20.Interruttore di alimentazione
 - 21.Porta spole
 - 22.Supporto porta spole
 - 23.Presa pedaglieria
 - 24.Regolatore lunghezza del punto
 - 25.Regolatore trasporto differenziale
 - 26.Volantino
 - 27.Coltello superiore
 - 28.Manopola disattivazione del coltello superiore
 - 29.Crochet destro (superiore)
 - 30.Crochet sinistro (inferiore)
 - 31.Crochet del punto catenella e del punto di copertura
 - 32.Dito di formazione del punto
 - 33.Coltello inferiore
- *Spostare il coperchio anteriore del crochet verso destra e tirare

ACCESSORI

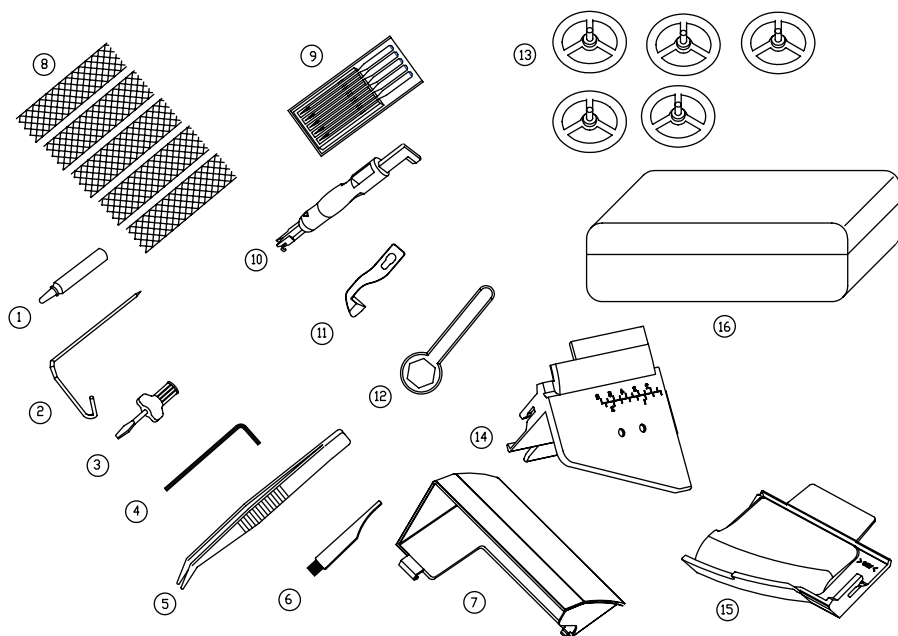

- | | |
|---|--|
| 1. Lubrificatore | 9. Set di aghi |
| 2. Righello guida | 10. Infilatore manuale |
| 3. Cacciavite | 11. Coltello superiore (рис.3) |
| 4. Brugola | 12. Chiave |
| 5. Pinzetta | 13. Fermi a disco per spole |
| 6. Pennello asporto di ritagli | 14. Inserto orizzontale del coperchio dei crochet per punto di copertura |
| 7. Contenitore raccolta ritagli di stoffa | 15. Inserto superiore del coperchio dei crochet |
| 8. Rete salvafilo per spole | 16. Contenitore per gli accessori |

PREPARAZIONE AL CUCITO

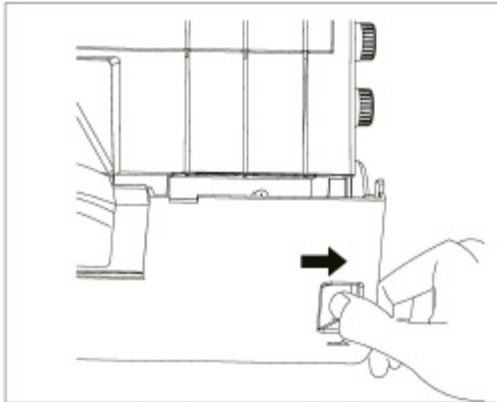

Coperchio dei crochet

Spostare il coperchio dei crochet verso destra quindi tirare.

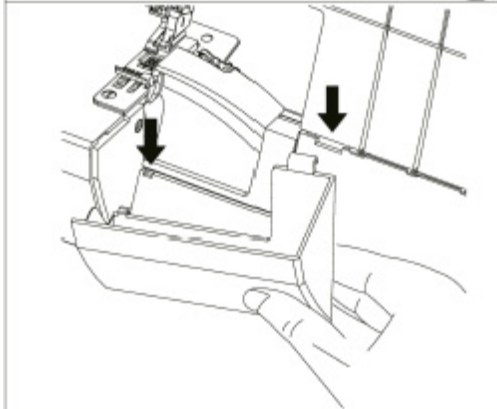

Contenitore di raccolta dei ritagli di stoffa

Premere sulla parte inferiore finché il gancio d'arresto inferiore non entri nell'apertura.

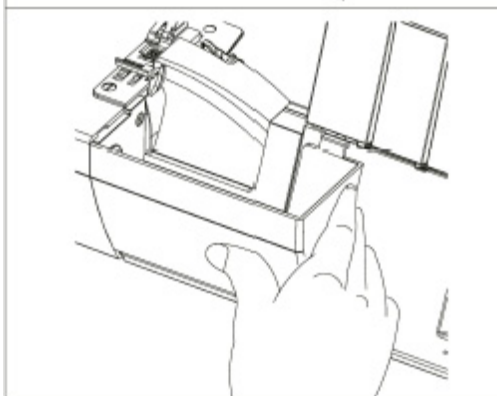

Per togliere il contenitore ripetere questa operazione.

ASTA GUIDAFILO TELESCOPICA / PORTA SPOLE / FERMI A DISCO PER SPOLETTE

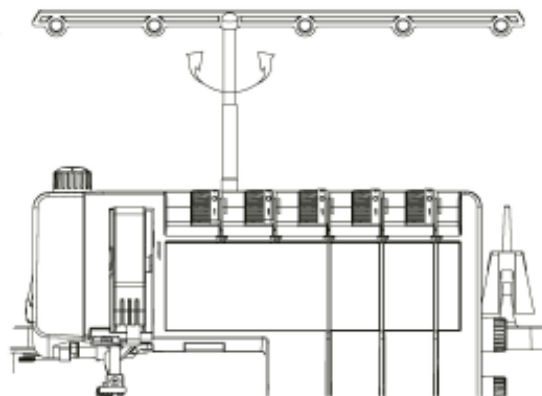

Asta guidafilo telescopica

Estrarre completamente l'asta guidafilo telescopica. Per ottimizzare l'avanzamento del filo girare l'asta telescopica finché s'innesta con uno scatto.

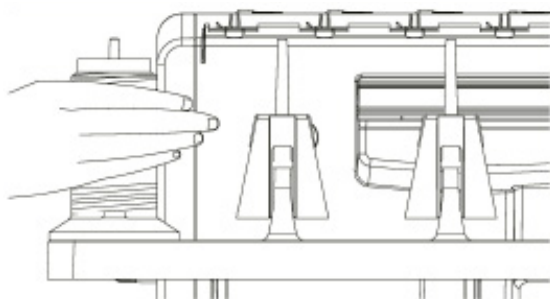

Porta spole

Per spole grandi (5 000- -10 000mm) usare porta spole e fermi per spolette. Se si usano i fili sintetici i dischi di polipropilene tengono i fili caduti dalle spole.

I porta spole servono per fissare bene le spole sui perni.

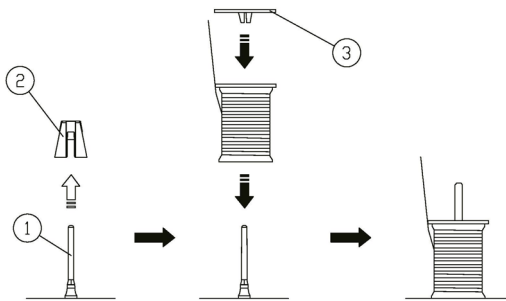
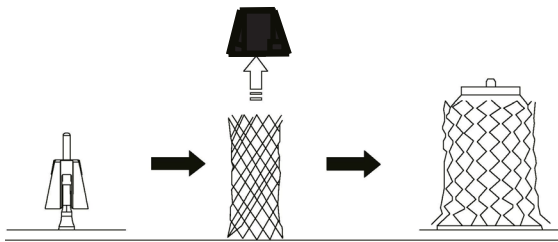

- 1) Perno per spole e spolette
- 2) Porta spole
- 3) Fermo a disco per spolette

Fermi a disco per spolette

Se durante l'infilatura e/o il cucito il filo cade dalla spoletta mettere la rete salvafilo sulla spoletta.

Usando le spolette togliere i porta spole e mettere i fermi a disco sopra le spolette.

SALITA DEL PIEDINO E DEGLI AGHI

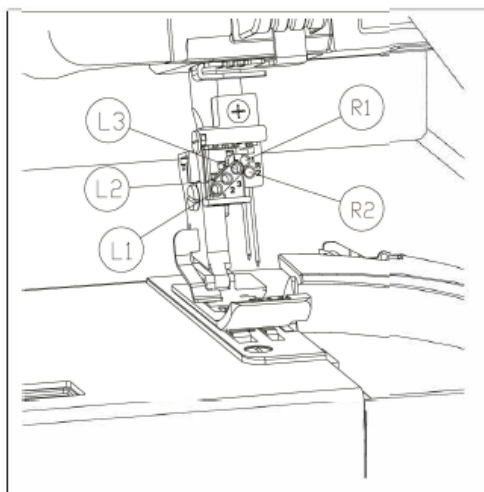

Si puo' cucire scegliendo tra 5 posizioni degli aghi. Si puo' cucire usando contemporaneamente 3 aghi.

△ Nota:

Se gli aghi sono inseriti nei fori R1 e R2 l'ago sinistro e' posizionato piu' in alto rispetto all'ago destro.

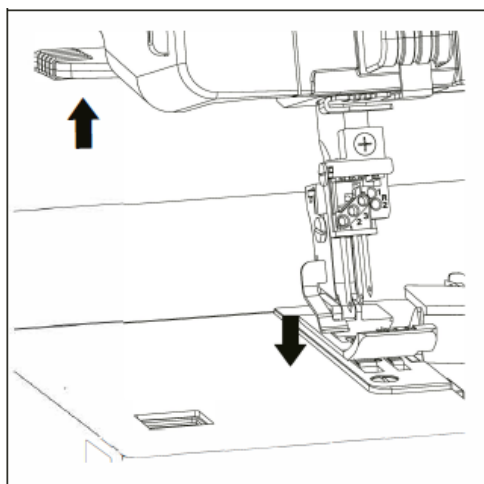

Se si usano gli aghi L2 e L3, l'ago sinistro e' posizionato piu' in basso rispetto all'ago destro. Se si usano gli aghi L1 e L3 l'ago sinistro e' posizionato sempre piu' in basso rispetto al ago destro. Se si usano gli aghi L1, L2 e L3, l'ago sinistro si trova nella posizione piu' bassa.

Il piedino si alza e si abbassa con la leva alzapiedino.

△ Nota:

Durante il cucito il piedino deve essere abbassato.

SOSTITUZIONE DEGLI AGHI

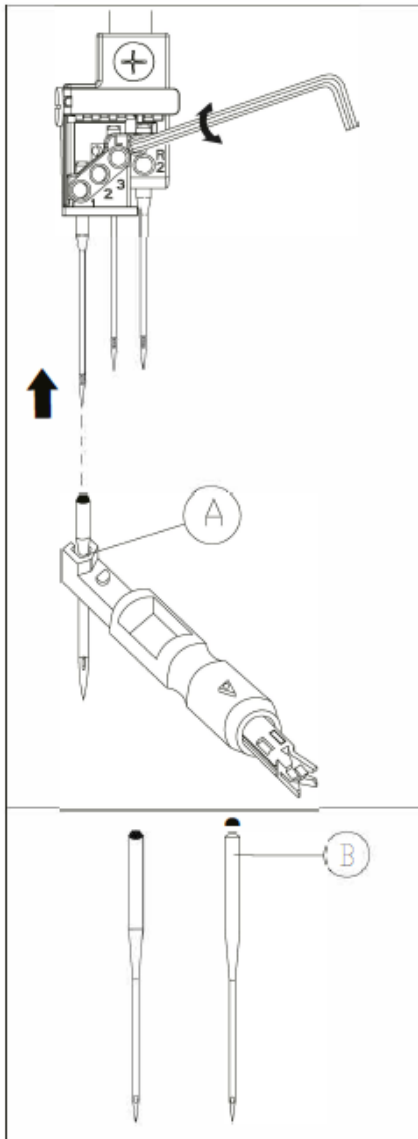

SPEGNERE LA MACCHINA!

Togliere l'ago: Abbassare il piedino ed alzare gli aghi nella posizione piu' alta.

Inserire l'ago fino al suo arresto nell'apposito ritegno, che si trova nel contenitore degli accessori. Allentare ma non svitare la vite usando la chiave a brugola e togliere l'ago tirando verso il basso.

Inserire l'ago: Inserire l'ago nel foro A dell'apposito ritegno con il taglio B rivolto indietro. Inserire l'ago nel basamento del morsetto fino all'arresto e serrare usando la chiave a brugola. Togliere il ritegno dell'ago. Gli aghi da usare

Sistema aghi	Dimensioni aghi	Tipo stoffa
EL x 705	11-14 (75-90)	Stoffe leggere e medie tipo seta, cotone, stretch, tessuto a maglia, jeans ecc.

ALLACCIAMENTO ELETTRICO

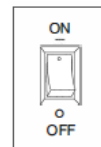
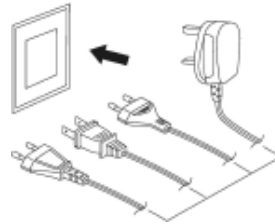
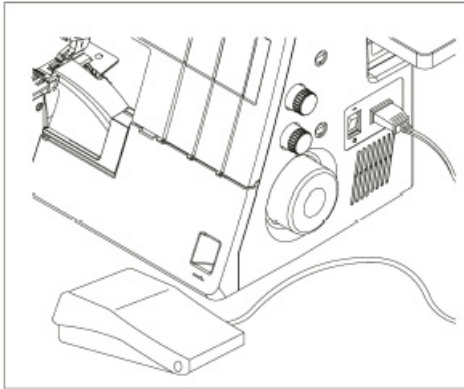

Attenzione: assicurarsi che la macchina e' staccata dalla rete e l'interruttore e' posizionato su «0» quando la macchina non viene usata oppure prima della sostituzione o spostamento degli elementi.

Prima di collegare il cavo di alimentazione con la rete assicurarsi che la tensione indicata sulla macchina corrisponda alla tensione di rete.

Posizionare la macchina su una superficie stabile.

1. Inserire la spina della macchina nella presa della macchina.
2. Collegare la spina di rete con la presa di rete. Accendere la macchina. La lampadina di illuminazione del campo di lavoro si accendera' una volta che e' presente il collegamento elettrico.
3. Accendere la macchina.
4. La lampadina di illuminazione del campo di lavoro si accendera' una volta che la macchina e' accesa.

Per staccare l'alimentazione posizionare l'interuttore su «0», quindi scollegare la spina di rete dalla presa.

INIZIO DEL CUCITO



Staccare l'alimentazione ed inserire la spina della macchina nella presa della macchina.

Inserire la spina della rete nella presa della rete.

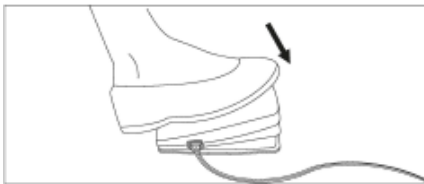

La velocità di cucito è regolata dalla pedagliera. Più è forte la pressione sulla pedagliera tanto maggiore è la velocità della macchina. Alzare il piedino, premere la pedagliera provando le varie velocità.



Per la vostra sicurezza:

- Durante il lavoro guardare sempre l'area di cucito. Non toccare le parti in movimento della macchina, cioè il guidafilo, il crochet, il volantino, gli aghi, i coltelli.
- Staccare sempre l'alimentazione se:
 - la macchina rimane fuori controllo
 - bisogna sostituire o aggiungere qualche dettaglio
 - infilare oppure pulire la macchina
- Non mettere nessun oggetto sulla pedagliera soprattutto durante il funzionamento della macchina.

REGOLAZIONE DI PRESSIONE DEL PIEDINO

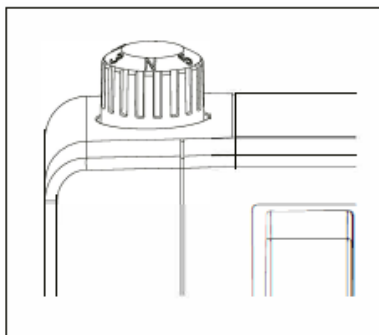

Per la cucitura ordinaria non c'è bisogno di cambiare la pressione del piedino sulla stoffa. Per la lavorazione dei vari tipi di stoffe girare la vite di regolazione a seconda del tipo di stoffa.

Si può scegliere tra sei posizioni. La pressione standard del piedino è in posizione «N».

△ Nota:

Abbassate il piedino prima di girare la manopola di regolazione della pressione del piedino. Questo renderà più facile girare la manopola.

INFILATURA DELLE GUIDE DEI FILI

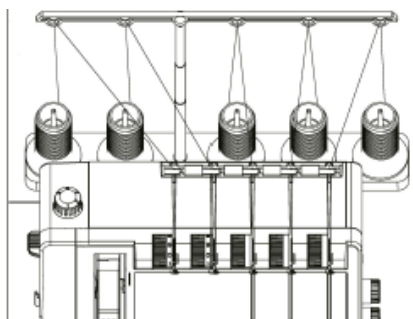

Prima di fare l'infilatura spegnere la macchina e staccare la spina dalla presa di rete.

La sequenza di operazioni di infilatura della macchina è seguente:

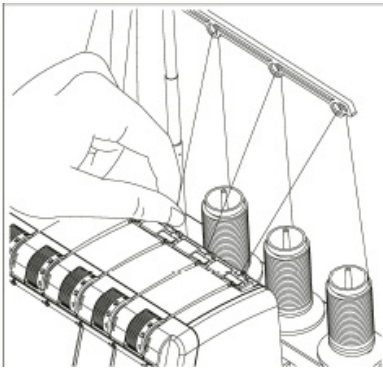

- 1) Filo del crochet sinistro
 - 2) Filo del crochet destro
 - 3) Filo dell'ago sinistro
 - 4) Filo dell'ago destro
- Alzare il piedino.

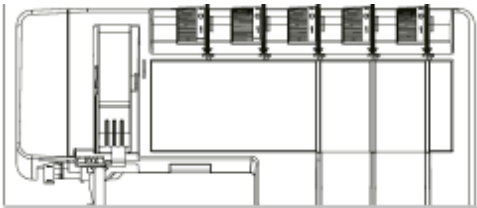

La sequenza delle operazioni di infilatura

INFILATURA DEL CROCHET DESTRO (SUPERIORE)

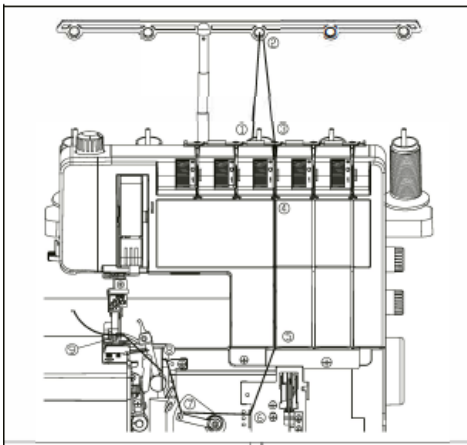

Girare il volantino verso di se per portare il crochet nella sua posizione piu' alta.

A – crochet superiore

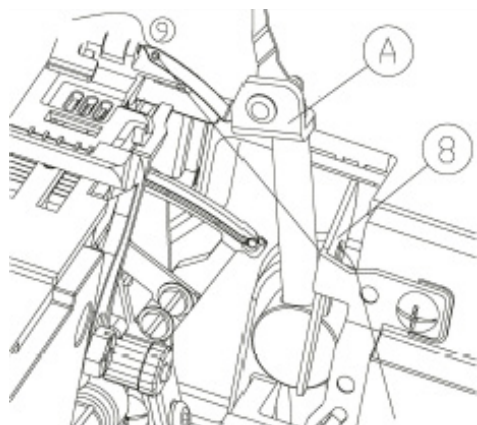

Infilare le guide del filo secondo i punti da 1 a 7.

Fare passare il filo sopra la guida del filo 8 e quindi in giu' e verso sinistra finche' non entra nella forcina guida.

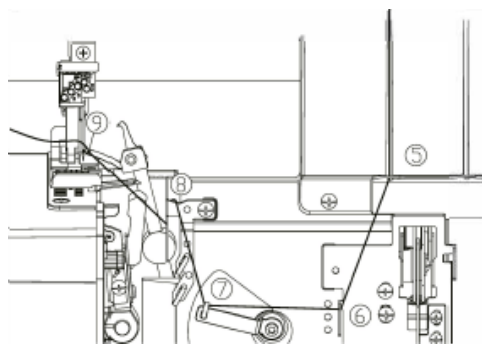

Infilare l'occhietto del crochet 9 verso fuori e tirare lasciando 10 cm. di filo da inserire sotto il piedino.

INFILATURA DEL CROCHET SINISTRO (INFERIORE)

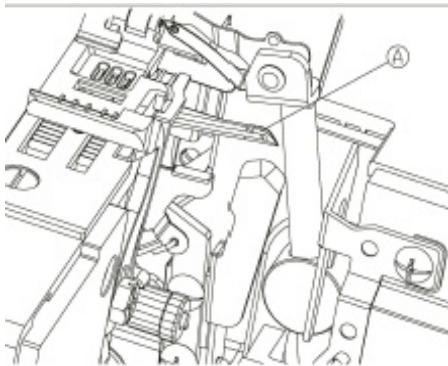

Girare il volantino verso di se per portare il crochet nella sua posizione di destra.

A – crochet inferiore

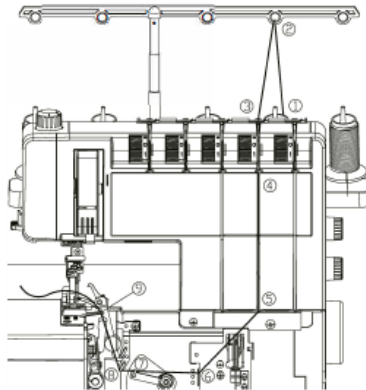

Infilare le guide del filo secondo i punti da 1 a 9.

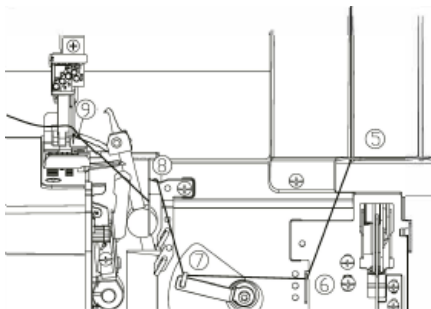

Abbassare la leva (a) e mettere il filo sulla guida (b). Infilare l'occhietto (c) del lato destro del crochet.

Quindi tirare il filo lasciando 10 cm. da inserire sotto il piedino.

INFILATURA DEL CROCHET DELLA CATENELLA (PER IL PUNTO DI COPERTURA ED IL PUNTO CATENELLA)

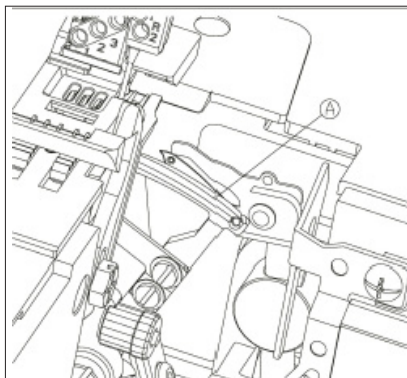

Girare il volantino per portare il crochet della catenella nella sua posizione estrema di destra.

A – crochet della catenella

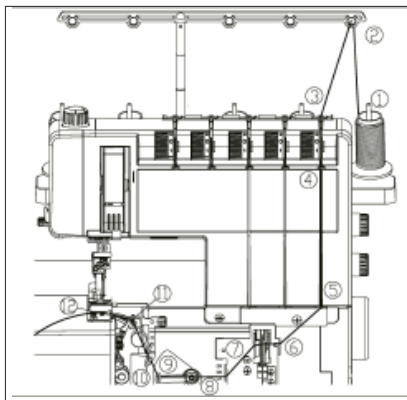

Infilare la guida del filo secondo i punti da 1 a 12.

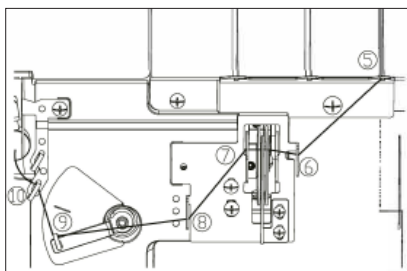

△ Nota:

Durante l'infilatura come da punti 6 e 7 il filo viene posato sopra e non viene inserito per trapasso.

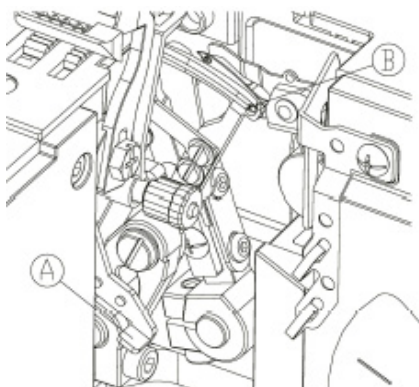

Alzare la leva (A) ed infilare l'apertura (B).

△ Nota:

La leva torna nella posizione di partenza appena inizia la cucitura.

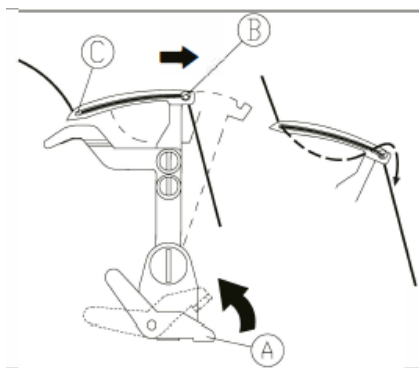

Infilare l'occhietto del crochet (C) verso avanti.

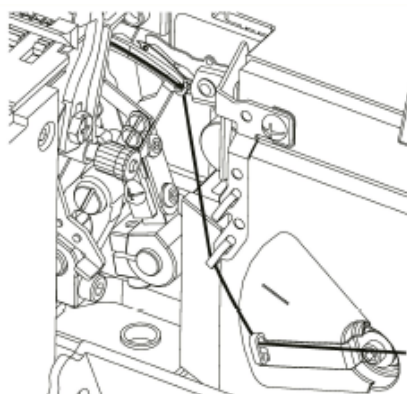

Tirare il filo lasciando 10 cm. da inserire sotto il piedino

INFILATURA DEGLI AGHI

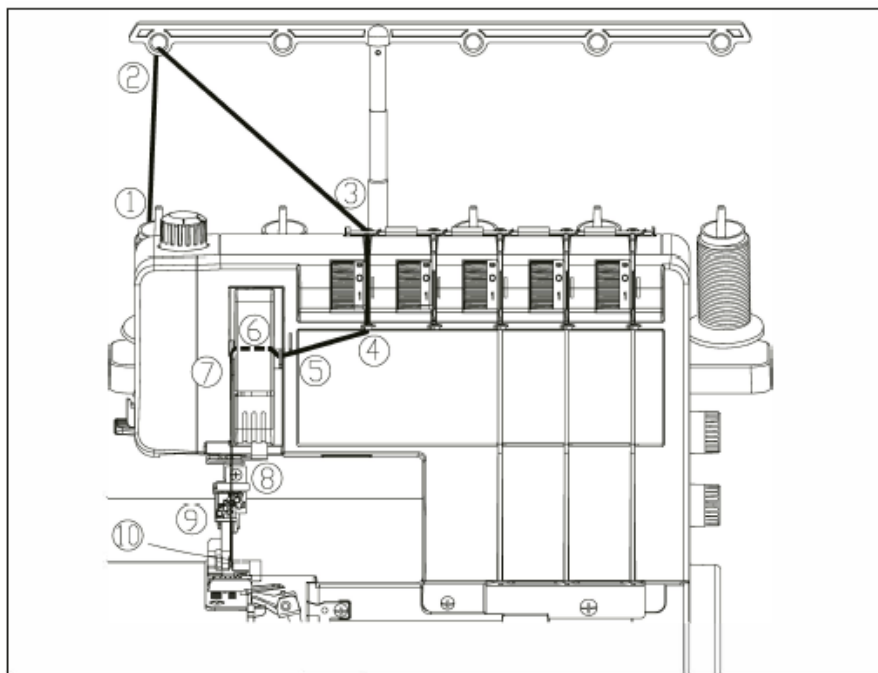

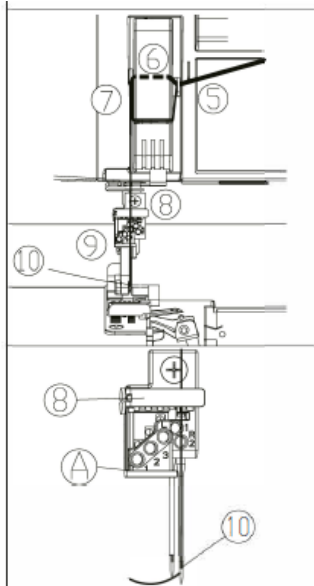

Inserire i fili secondo i punti da 1 a 10. Il filo deve passare nell'apertura inferiore della guida del filo 5

Tirare 10 cm. di filo e farlo passare sotto il piedino.

Se durante il cucito vengono impiegati gli aghi L1, L2 oppure L3, bisogna usare la guida del filo A.

(A) – guida del filo A

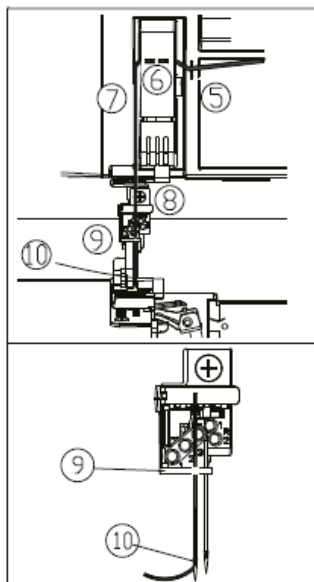

Eccezione: Infilare l'ago L3 per realizzare il punto catenella e punto overlock a 5 fili (Programma 20) e per realizzare il punto catenella e punto overlock a 4 fili (Programma 19) nonché per realizzare il punto catenella a 2 fili (Programma 04).

Inserire il filo osservando la sequenza indicata nei punti da 1 a 10.

Il filo deve passare attraverso l'apertura superiore della guida del filo 6.

Tirare 10 cm di filo e farlo passare sotto il piedino.

△ Nota:

Infilando il crochet della catenella (Programma 04) bisogna infilare il frenafilo colore verde.

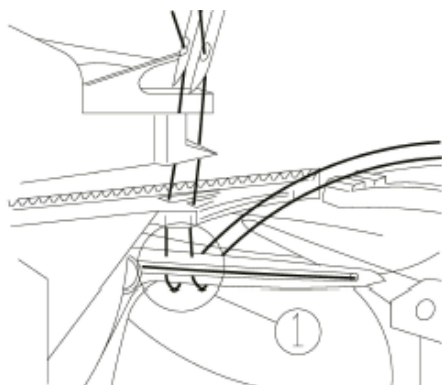
**Importante:**

Gli aghi debbono sempre essere infilati per ultimi per evitare che i fili degli aghi si trovino sotto i fili dei crochet (vedi il disegno 1). I fili degli aghi invece debbono essere posti sopra i fili dei crochet (vedi il disegno 2) altrimenti puo' accadere la rottura dei fili.

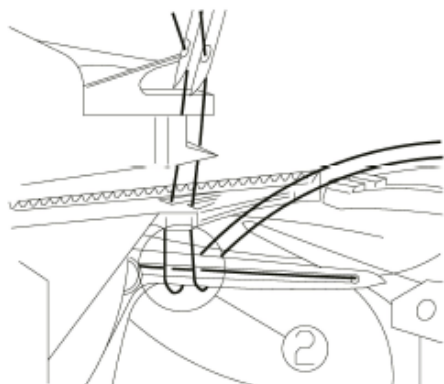

Nel caso della rottura dei fili bisogna estrarre i fili dagli aghi ed infilare i crochet e quindi infilare gli aghi.

INFILATORE DELL'AGO MANUALE

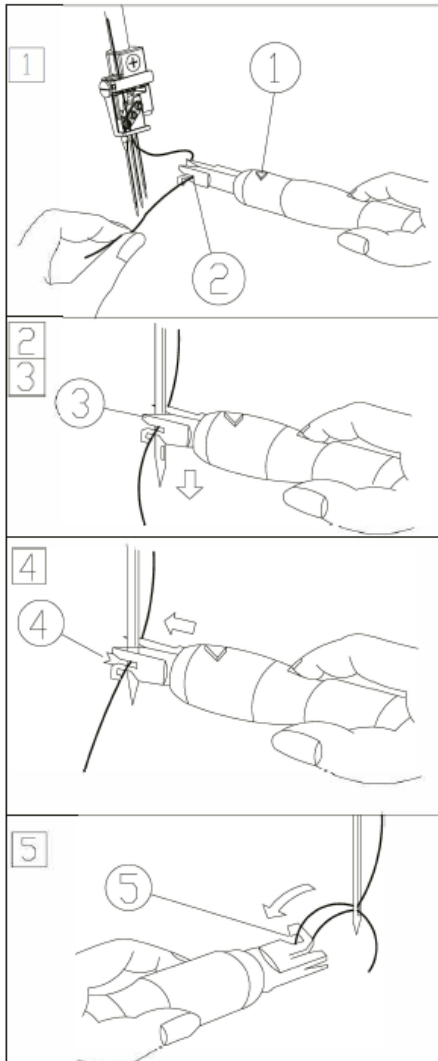

SPEGNERE LA MACCHINA!

Portare gli aghi nella posizione superiore massima ed abbassare il piedino.

Inserire il filo da destra verso sinistra nella fessura dell'infilatore A. .

Una delle due marcature triangolari deve essere rivolta in alto.

Posizionare l'infilatore di fronte al canaletto dell'ago appoggiandolo contro l'ago, quindi scendere verso la cruna e premere leggermente l'infilatore in direzione attraverso la cruna. La linguetta metallica dell'infilatore entra nella cruna ed infila automaticamente l'ago.

Usare il gancio 5 per tirare il cappio di filo attraverso la cruna.

Δ Nota: Non premere l'infilatore troppo contro l'ago, altrimenti la linguetta metallica potrebbe piegarsi il che potrebbe causare la rottura dell'infilatore.

SHEMA GENERALE DI INFILATURA PER TUTTI I TIPI DI PROGRAMMI

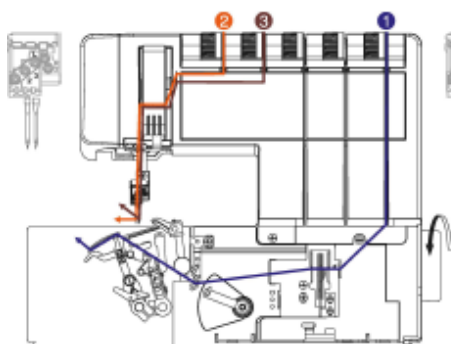

Programma 01
Punto di copertura a 2 aghi, stretto
(L2/L3).

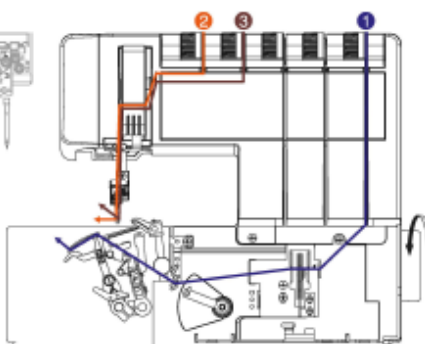

Programma 02
Punto di copertura a 2 aghi, largo
(L1/L3).

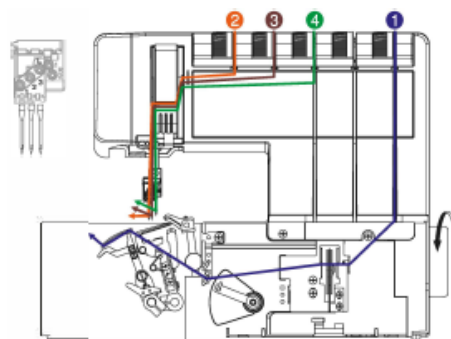

Programma 03
Punto di copertura a 3 aghi (L1/L2/
L3)

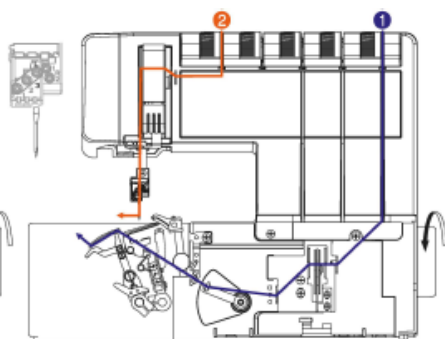

Programma 04
Punto catenella (L3) (punto
catenella a 1 ago) .

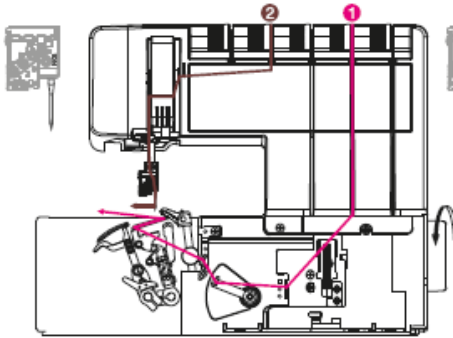

Programma 05
Punto FlatLock a 2 fili, stretto (R2)

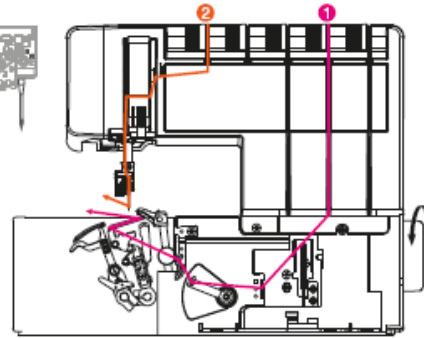

Programma 06
Punto FlatLock a 2 fili, largo (R1)

Programma 07
Punto Overlock a 2 fili, stretto (R2)

Programma 08
Punto orlo arrotolato paiatto a 2 fili (R2)

Programma 09
Punto orlo arrotolato a 2 fili (R2)

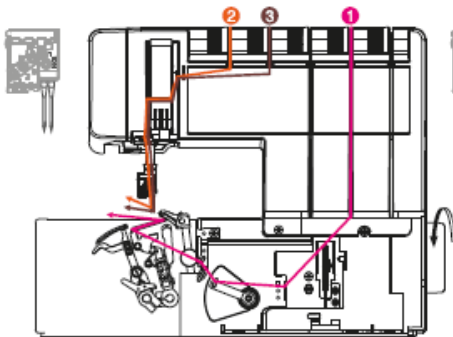

Programma 10
Punto Overlock a 2 aghi a 3 fili (R1/
R2)

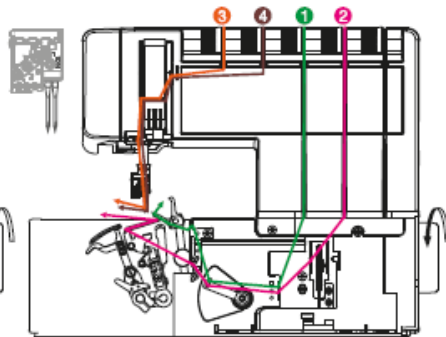

Programma 11
Punto Overlock a 4 fili, (R1/R2)

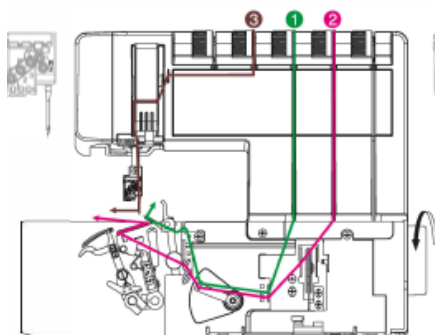

Programma 12
Punto Overlock a 3 fili, stretto (R2)

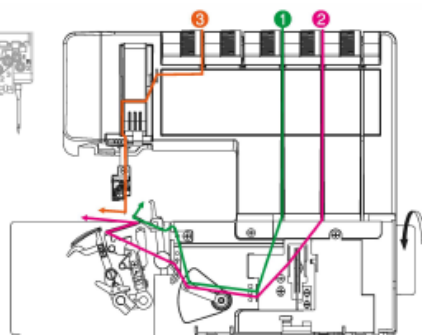

Programma 13
Punto Overlock a 3 fili, largo (R1)

Programma 15
Punto FlatLock a 2 fili, stretto (R2)

Programma 14
Punto Overlock a 3 fili, stretto (R1)

Programma 17
Punto orlo arrotolato piatto a 3 fili(R2)

Programma 16
Punto FlatLock a 3 fili, largo (R1)

Programma 18
Punto orlo arrotolato invisibile a 3 fili(R2)

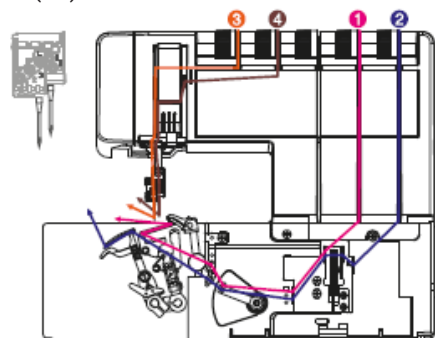

Programma 19
Punto catenella e punto overlock a 4 fili (L3/R1)

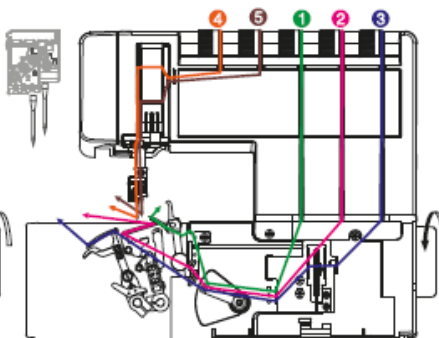

Programma 20
Punto catenella e punto overlock a 5 fili, largo).

TAGLIAFILI INCORPORATO

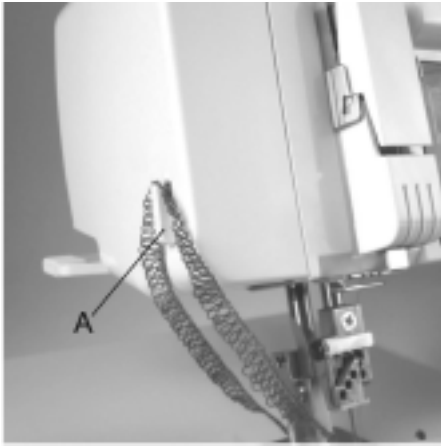

Al termine della cucitura lasciare una treccia di fili lunga 15-20 cm. e tirarla fino al coltello del tagliafili. Questa operazione permette di tagliare il filo.

A – tagliafili



Posizionare la stoffa direttamente di fronte agli aghi, usando le forbici fare, se necessario, un taglio di 3 cm. lungo il taglio della stoffa, quindi abbassare il piedino e cominciare a cucire. La cucitura si forma automaticamente lungo il taglio.

△ Nota:

Questo metodo é' adatto per il punto di copertura



Fissare il contenitore di raccolta dei ritagli al coperchio anteriore dei crochet per accumulare ritagli di stoffa.

DISATTIVAZIONE DEL COLTELLO SUPERIORE

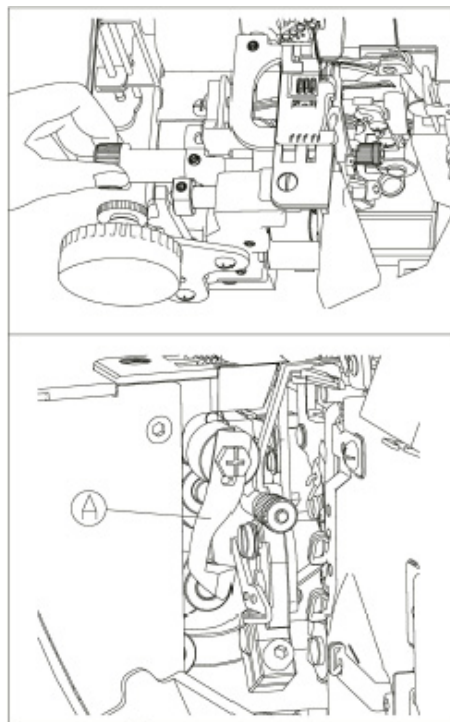

SPEGNERE LA MACCHINA!

Togliere il contenitore di raccolta dei ritagli, aprire il coperchio anteriore dei crochet e il coperchio sinistro del piano di cucito. Alzare il coltello superiore per portarlo nella posizione più alta girando il volantino.

Premere la manopola di disattivazione del coltello superiore fino all'arresto verso destra.

A – coltello superiore

Girare la manopola verso avanti finché il coltello superiore non scenderà giù. Il coltello è disattivato

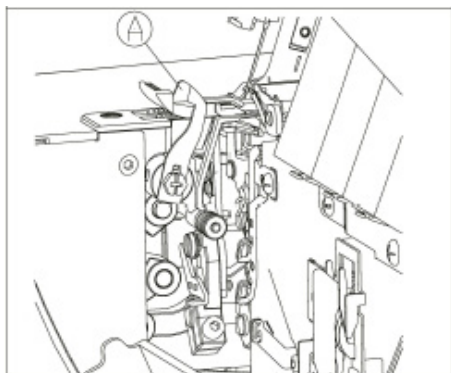

Attivazione del coltello superiore.

Premere la manopola fino all'arresto verso destra e girarla verso indietro fino allo scatto. Il coltello ritornerà nella posizione di lavoro. Chiudere il coperchio dei crochet e il coperchio sinistro del piano di cucito. Riattaccare il contenitore di raccolta dei ritagli.

DISATTIVAZIONE DELL'ALLARGATORE

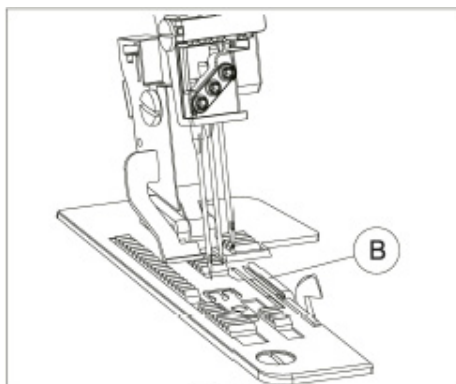

Per punti Overlock standard.

Per effettuare tutte le cuciture Overlock standard (Programmi 02, 04) l'allargatore deve trovarsi nella sua posizione di partenza.

A – manopola disattivazione allargatore

B – allargatore.

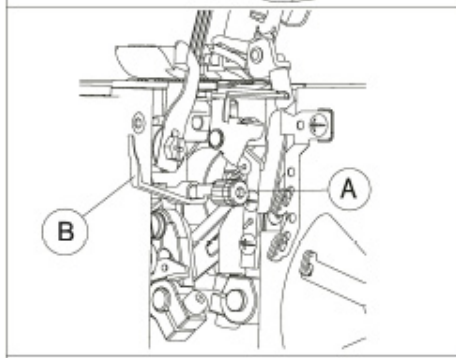

Per orlo arrotolato.

Togliere il contenitore di raccolta dei ritagli ed aprire il coperchio anteriore dei crochet. Tirare la manopola A verso destra, abbassare l'allargatore portandolo in posizione di riposo girando la manopola verso di se.

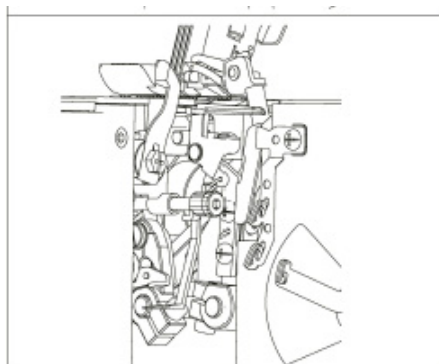

Queste impostazioni permettono di fare tutti i tipi di orlino arrotolati nonché i punti di copertura ed i punti decorativi (Programmi 02,04).

CONVERTITORE DEL CROCHET DESTRO (SUPERIORE)

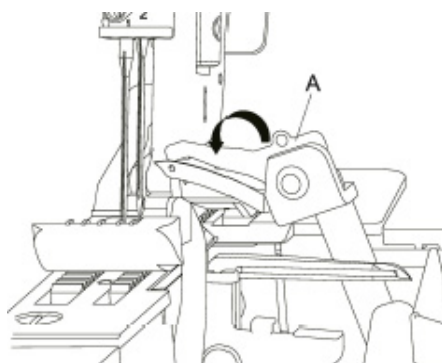

Attivazione del convertitore a 2 fili: Girare il volantino per portare il crochet destro (superiore) nella posizione massima superiore.

Abbassare il convertitore ed inserire il suo gancio nell'occhietto del crochet.

A – convertitore a 2 fili

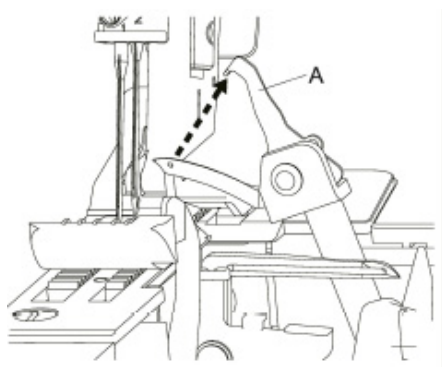

Disattivazione del convertitore a 2 fili: Girare il volantino per portare il crochet destro (superiore) nella posizione massima superiore. Estrarre il gancio del convertitore dall'occhietto del crochet ed alzare il convertitore riportandolo nella posizione di partenza (posizione superiore destra).

DISATTIVAZIONE DEL CROCHET DESTRO (SUPERIORE)

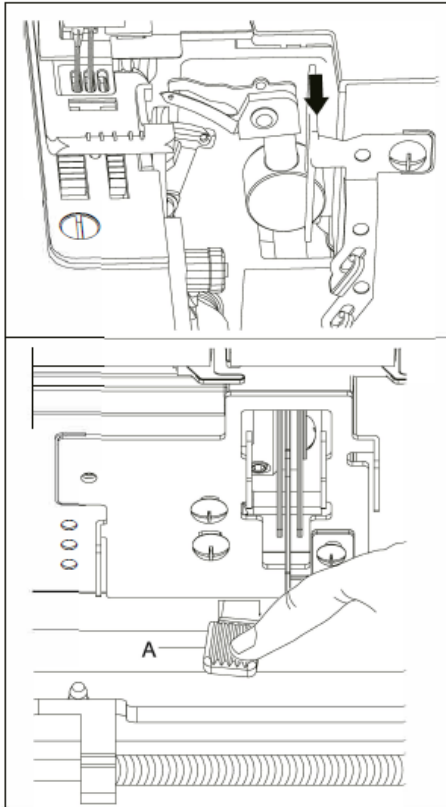

Per effettuare la cucitura a punto di copertura ed a punto catenella e' necessario disattivare il crochet destro (superiore) adoperando la leva di arresto. Togliere il contenitore di raccolta dei ritagli ed aprire il coperchio anteriore dei crochet.

Girare il volantino per portare il crochet nella posizione massima inferiore.

A – leva di arresto del crochet destro (superiore)

Premere la leva di arresto del crochet in giu' e spostarla verso sinistra. Girare il volantino per assicurarsi che il crochet non si muove.

Per attivare il crochet destro superiore premere la leva di arresto del crochet e riportarla nella posizione di partenza.

Girare il volantino finche' il crochet non comincia a salire con un apposito scatto.

Chiudere il coperchio anteriore e rimettere il contenitore di raccolta dei ritagli sul suo posto.

REGOLAZIONE DELLA LUNGHEZZA DEL PUNTO E DEL TRASPORTO DIFFERENZIALE DELLA STOFFA

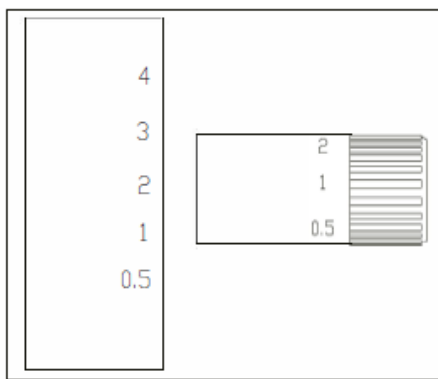

Girare il regolatore di lunghezza del punto per scegliere la lunghezza richiesta.

La lunghezza del punto puo' essere impostata nei limiti da 0,5 a 4.

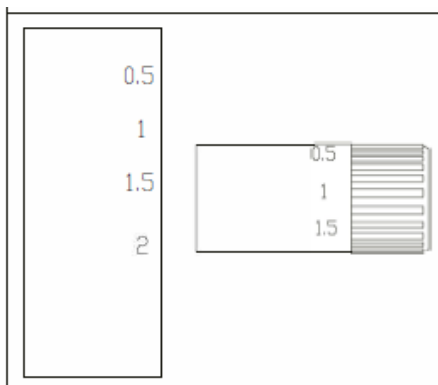

Girare il regolatore del trasporto differenziale della stoffa per scegliere il coefficiente.

Il trasporto differenziale puo' essere impostato nei limiti da 0,5 a 2.

SOSTITUZIONE DELL'INSERTO SUPERIORE DEL COPERCHIO DEI CROCHET

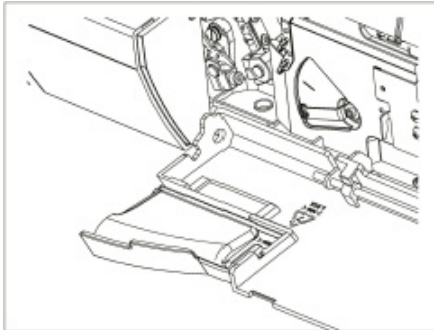

Togliere il contenitore di raccolta dei ritagli ed aprire il coperchio dei crochet. Tirare l'inserto del coperchio dei crochet in su' e verso di se.

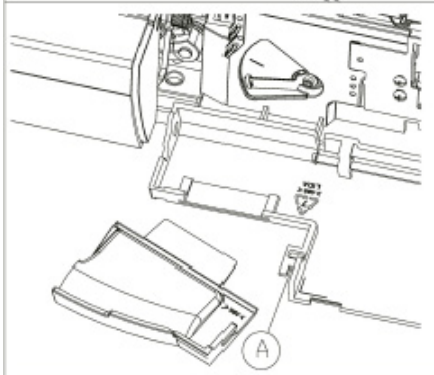

Per inserire la piattaforma orizzontale per la cucitura a punti di copertura nel coperchio anteriore bisogna metterla sotto il gancio d'arresto A , quindi premere lungo le guide del coperchio anteriore.

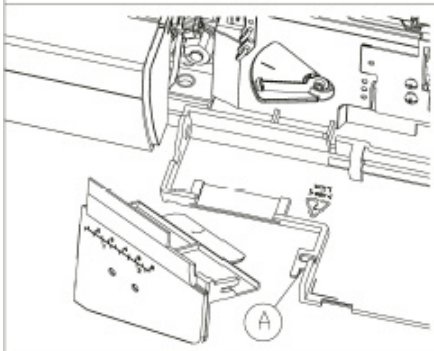

△ Nota:

La piattaforma orizzontale e' segnata con le tacche di misurazione. Le tacche superiori sono in centimetri, le tacche inferiori sono in pollici

REGOLAZIONE DELLA LARGHEZZA DI TAGLIO DELLA STOFFA

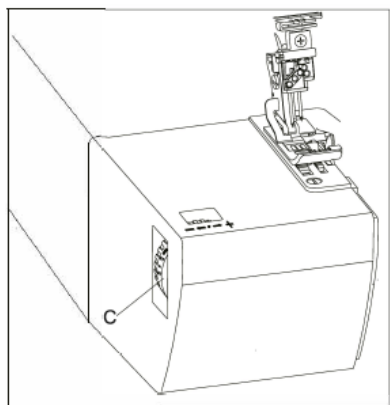

Girare la manopola di regolazione della larghezza di taglio della stoffa per scegliere un valore nei limiti da 3,5 a 6,0 mm.

Nota: Il punto catenella viene effettuato con valori da 0,5 a 9.

C – manopola di regolazione della larghezza di taglio della stoffa

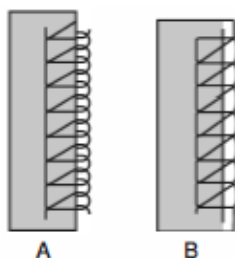

Disegno A, se i punti vanno oltre l'orlo di taglio della stoffa bisogna ruotare la manopola del regolatore in su' per spostare il coltello verso destra.

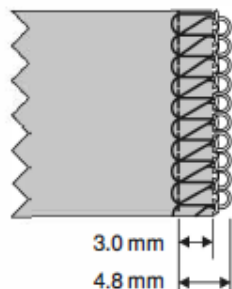

Disegno B, se i punti stringono l'orlo di taglio della stoffa bisogna ruotare la manopola del regolatore in giu' per spostare il coltello verso sinistra.

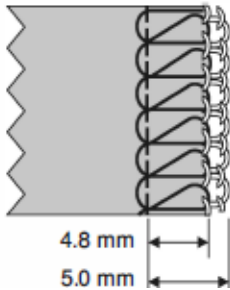

△ Nota: La larghezza di taglio impostata tra i valori da 4,8 mm a 5,0 mm, ha l'importanza solamente per l'ago R1. Questo valore si diminuisce di 2 mm se viene usato l'ago R2

MONTAGGIO DEL RIGHELLO GUIDA

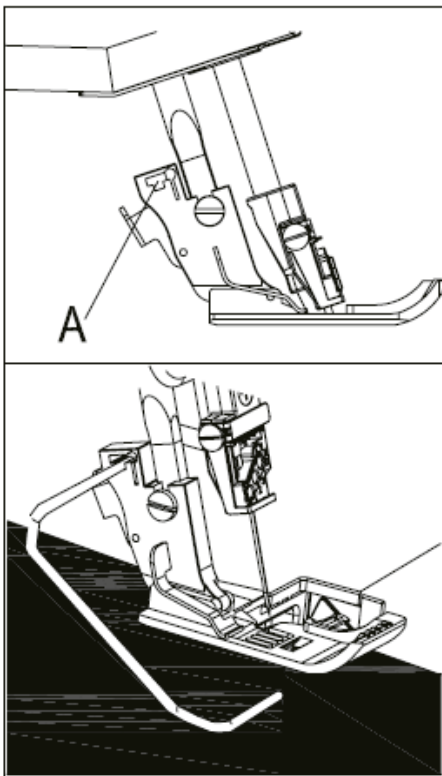

! SPEGNERE LA MACCHINA!

Inserire il righello guida per la cucitura ed il quilting nell'apertura A del ritegno del piedino da sinistra verso destra.

E' possibile regolare il righello secondo le esigenze personali spostandolo verso sinistra/ destra nel ritegno del piedino.

Queste regolazioni possono essere usate per tutti i tipi di cucitura a punti orlo arrotolato.

SOSTITUZIONE DEL COLTELLO SUPERIORE

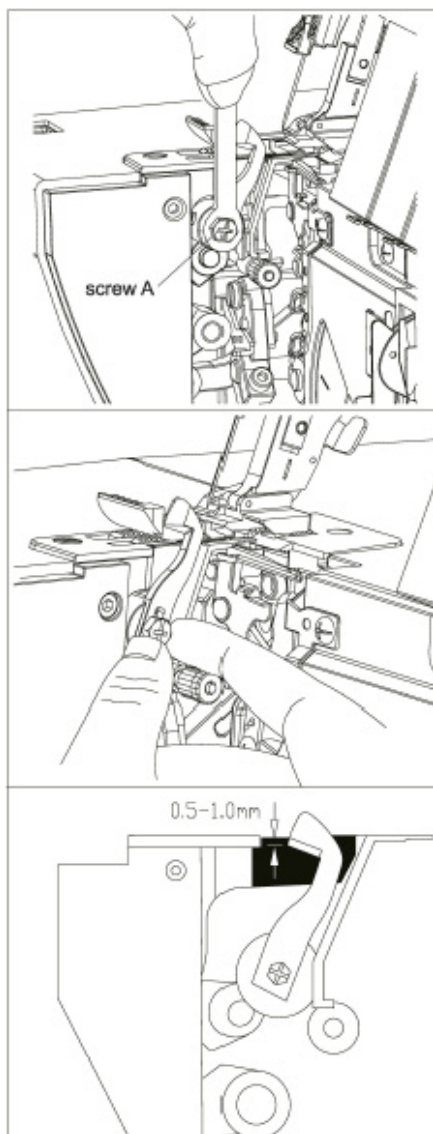

Smontaggio del coltello:

Posizionare il regolatore della larghezza del taglio della stoffa su 3,5 mm. Allentare la vite A con la chiave del set accessori e togliere il coltello superiore.

Montaggio del coltello:

Posizionare il coltello superiore e stringere leggermente la vite A. Girare il volantino per portare il coltello superiore nella posizione massima inferiore.

Nella sua posizione inferiore l'estremità anteriore del coltello superiore deve essere posizionata di 1 mm. più giu' rispetto alla lama del coltello inferiore se il coltello superiore è montato correttamente. Stringere completamente la vite A.

MANUTENZIONE DELLA MACCHINA

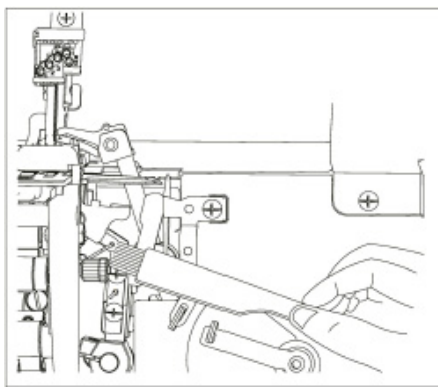

Usando il pennello del set accessori asportare polvere e residui di stoffa e di fili dal coltello superiore e quello inferiore, dalle cremagliere e dalla zona dei crochet.



SPEGNERE LA MACCHINA!

Pulizia della macchina.

Togliere il contenitore di raccolta dei ritagli di stoffa. Aprire il coperchio superiore dei crochet ed il coperchio del piattaforma sinistro. Disattivare il coltello superiore. Togliere il piedino e la placca d'ago.

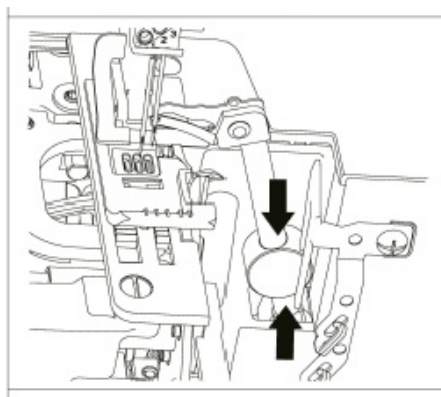

Lubrificazione della macchina.

Posizionare il crochet destro (superiore) nella posizione massima superiore girando il volantino. Ogni volta dopo la pulizia lubrificare la zona indicata con le frecce sul disegno. Sono sufficienti 1-2 gocce del olio.

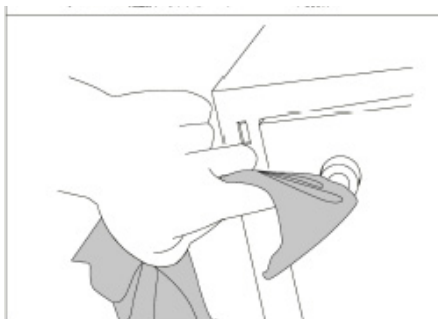
**Pulizia dei piedini di gomma.**

Ognitanto pulire i piedini di gomma con alcool metilico. Questa operazione permette di eliminare la vibrazione della macchina durante il cucito.

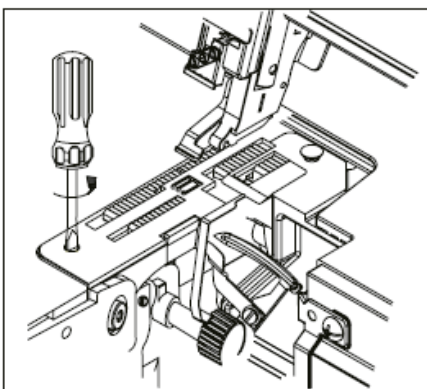
**Smontaggio della placca d'ago.**

Estrarre gli aghi, togliere il piedino ed il ritegno del piedino.

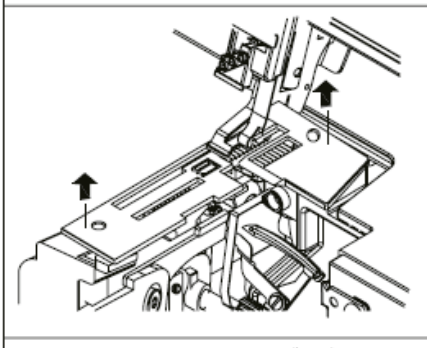



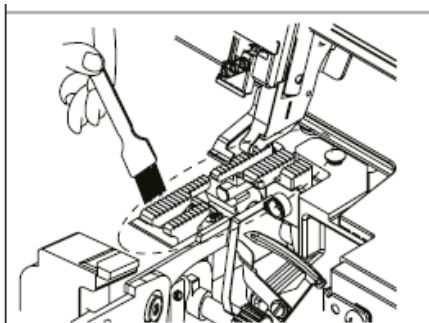







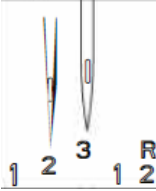
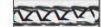

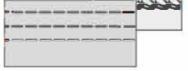

Svitare le viti di fissaggio della placca d'ago e toglierla.



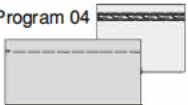
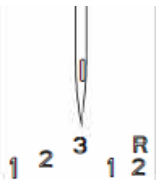
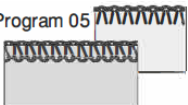
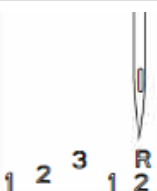
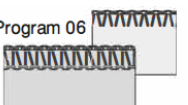





Pulire la zona dei crochet e della cremagliera con il pennello del set accessori.

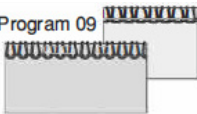
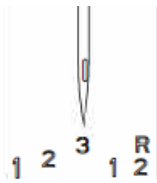

PUNTI DI COPERTURA, PUNTI CATENELLA E PUNTI OVERLOCK, ESEMPI DI REGOLAZIONI

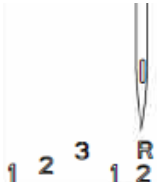
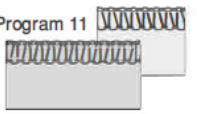
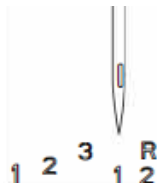

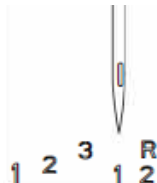
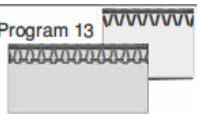
Programmi	Posizione ago	Lunghezza punto	Larghezza punto	Tensione dei fili
Program 01  	 1 2 3 1 R 2	2.5	5.0	5.0 5.0 _ _ 1.0
Program 02  	 1 2 3 1 R 2	3.0	5.0	5.0 5.0 _ _ 1.0
Program 03  	 1 2 3 1 R 2	3.0	5.0	5.0 4.5 5.0 _ 1.0





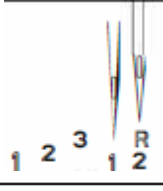
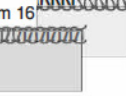
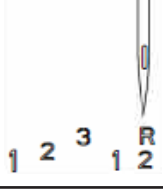
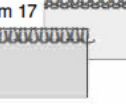
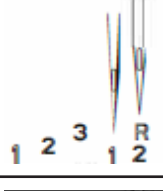
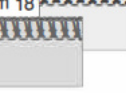
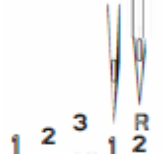

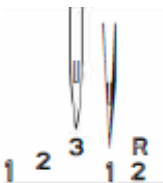

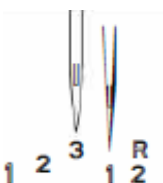

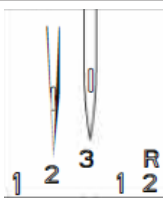
Programmi	Posizione ago	Lunghezza punto	Larghezza punto	Tensione dei fili
Program 04 		3.0	5.0	3.0 _ _ _ _ 1.5
Program 05 		2.0	5.5	_ 1.5 _ _ 6.0 _
Program 06 		2.0	5.5	1.5 _ _ _ 6.0 _
Program 07 		2.0	5.5	_ 5.0 _ _ 2.5 _
Program 08 		1.0	5.5	_ 1.5 _ _ 5.0 _

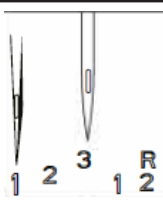

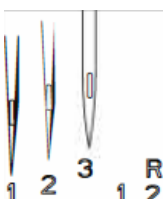

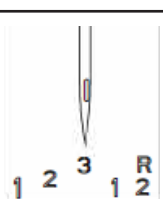

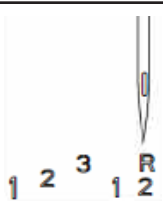





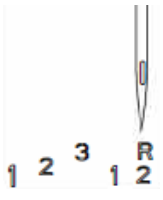

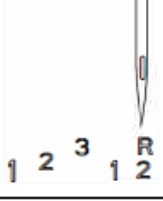

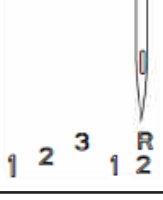

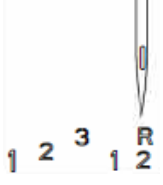







Programmi	Posizione ago	Lunghezza punto	Larghezza punto	Tensione dei fili
Program 09 		1.0	5.5	— <input type="text" value="3.0"/> — <input type="text" value="3.0"/> —
Program 10 		2.0	5.5	— <input type="text" value="3.5"/> <input type="text" value="3.5"/> <input type="text" value="2.5"/> —
Program 11 		2.0	5.5	<input type="text" value="3.0"/> — <input type="text" value="1.0"/> <input type="text" value="1.0"/> —
Program 12 		2.0	5.5	<input type="text" value="4.5"/> — <input type="text" value="0.5"/> <input type="text" value="7.5"/> —
Program 13 		1.0	5.5	— <input type="text" value="0.5"/> <input type="text" value="3.0"/> <input type="text" value="6.0"/> —

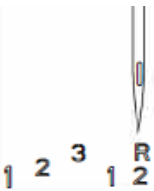





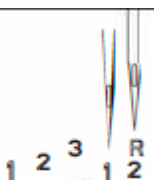



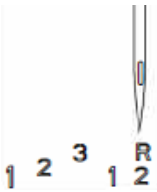

Programmi	Posizione ago	Lunghezza punto	Larghezza punto	Tensione dei fili
Program 14 		2.0	5.5	0.5 _ 2.5 7.0 _
Program 15 		2.0	5.5	4.0 2.0 _ 1.0 _
Program 16 		1.0	5.5	_ 2.5 3.5 2.0 _
Program 17 		1.0	5.5	_ 3.0 2.0 6.0 _
Program 18 		2.5	5.5	3.5 2.0 2.0 1.5 _

Programmi	Posizione ago	Lunghezza punto	Larghezza punto	Tensione dei fili
Program 19 		2.5	8.0	3.0 0.5 _ 4.0 1.5
Program 20 		3.0	8.5	3.0 2.5 1.0 1.0 1.5

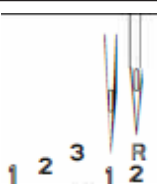
Posizione ago	Lunghezza punto	Larghezza cucitura	Trasporto differenziale	Coltello superiore	Crochet superiore	Convertitore a 2 fili	Perno di formazione del cappio
	2.5	5.0	1.0	X			X
	3.0	5.0	1.0	X			X
	3.0	5.0	1.0	X			X
	3.0	5.0	1.0	X			X
	2.0	5.5	1.0	V			V

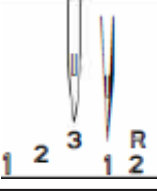
Posizione ago	Lunghezza punto	Larghezza cucitura	Trasporto differenziale	Coltello superiore	Crochet superiore	Convertitore a 2 fili	Perno di formazione del cappio
 <p>1 2 3 1 2 R</p>	2.0	5.5	1.0	V			V
 <p>1 2 3 1 2 R</p>	2.0	5.5	1.0	V			V
 <p>1 2 3 1 2 R</p>	1.0	5.5	1.0	V			X
 <p>1 2 3 1 2 R</p>	1.0	5.5	1.0	V			X
 <p>1 2 3 1 2 R</p>	2.0	5.5	1.0	V			V

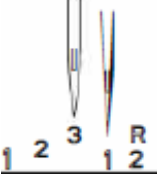
Posizione ago	Lunghezza punto	Larghezza cucitura	Trasporto differenziale	Coltello superiore	Crochet superiore	Convertitore a 2 fili	Perno di formazione del cappio
	3.0	5.5	1.0	V			V
	2.0	5.0	1.0	V			V
	2.0	5.5	1.0	V			V
	2.0	5.5	1.0	V			V
	2.0	5.5	1.0	V			V

Posizione ago	Lunghezza punto	Larghezza cucitura	Trasporto differenziale	Coltello superiore	Crochet superiore	Convertitore a 2 fili	Perno di formazione del cappio
	1.0	5.5	1.0	V			X
	1.0	5.5	1.0	V			X
	2.5	5.5	1.0	V			X
	2.5	8.0	1.0	V			X
	3.0	8.5	1.0	V			V



TRIUMPHATOR 2500X

 www.effektiv.ie  info@effektiv.ie

Printed in EU / Impreso en la UE

EAC

CE



UK
CA



RoHS